

# Method ruggedness and robustness testing for Glyphosate monoammonium analysis

**Author:** BenchChem Technical Support Team. **Date:** May 2026

## Compound of Interest

Compound Name: *Glyphosate monoammonium*

CAS No.: 40465-66-5

Cat. No.: B12279329

[Get Quote](#)

## Technical Support Center: Glyphosate Monoammonium Analysis

This technical support center provides troubleshooting guidance and frequently asked questions (FAQs) for researchers, scientists, and drug development professionals engaged in the analysis of **glyphosate monoammonium**.

### Troubleshooting Guide

This guide addresses specific issues that may be encountered during the analysis of glyphosate and its primary metabolite, aminomethylphosphonic acid (AMPA).

Issue	Potential Cause(s)	Recommended Solution(s)
<p>Poor/Inconsistent Peak Shape (Tailing)</p>	<p>Interaction of the polar glyphosate/AMPA with active metal sites in the HPLC/UHPLC system (e.g., stainless steel tubing, column frit).[1][2]</p>	<p>1. System Passivation: Passivate the entire LC flow path by flushing with a solution of ethylenediaminetetraacetic acid (EDTA) (e.g., 40 mM EDTA) overnight at a low flow rate.[2] 2. Mobile Phase Additive: Incorporate a low concentration of a chelating agent like EDTA into the mobile phase to continuously chelate metal ions. However, be aware that high concentrations (<math>\geq 5\%</math>) can cause ion suppression in the mass spectrometer.[2][3] 3. Sample Additive: Add EDTA to the sample or extraction solvent to minimize metallic chelation and ensure reproducible retention times and peak shapes.[2][3][4]</p>
<p>Low Analyte Response / Poor Sensitivity</p>	<p>- Ion suppression due to matrix effects or high concentrations of mobile phase additives.[2][3]            - Inefficient ionization in the mass spectrometer source.[3] - Incomplete derivatization (if applicable).[5]</p>	<p>1. Optimize Sample Preparation: Employ effective sample cleanup techniques like Solid-Phase Extraction (SPE) or Quick Polar Pesticides (QuPPE) method to reduce matrix components.[6]            2. Use Isotope-Labeled Internal Standards: Incorporate stable isotope-labeled internal standards (e.g., Glyphosate-<math>^{13}\text{C}_2,^{15}\text{N}</math>) to compensate for matrix effects and variations in</p>

instrument response, thereby improving accuracy and precision.[7][8] 3. Optimize Derivatization: If using derivatization (e.g., with FMOC-Cl), ensure optimal reaction conditions (pH, reagent concentration, time) for complete derivatization.[3][9] 4. Adjust Mass Spectrometry Parameters: Optimize electrospray ionization (ESI) source parameters. Negative ion mode is commonly used for underivatized glyphosate, while positive or negative mode can be used for derivatized forms.[6][7]

---

### Poor Chromatographic Retention

The high polarity of glyphosate and AMPA makes them poorly retained on traditional reversed-phase columns (e.g., C18).[1][6]

1. Specialized Columns: Utilize columns designed for polar analytes, such as hydrophilic interaction liquid chromatography (HILIC), mixed-mode (e.g., reversed-phase/anion-exchange), or porous graphitic carbon (PGC) columns.[4] 2. Derivatization: Derivatize glyphosate and AMPA with a non-polar agent like 9-fluorenylmethylchloroformate (FMOC-Cl). The resulting derivatives are less polar and exhibit better retention on C8 or C18 columns.[6][10][11]

---

Irreproducible Retention Times	- Metallic chelation affecting analyte-column interaction.[3] - Changes in mobile phase composition or pH.[9] - Column degradation or contamination.	1. Metal Chelation Management: Implement the use of EDTA as described for poor peak shape.[3] 2. Mobile Phase Control: Ensure accurate and consistent preparation of mobile phases. Use a buffer to maintain a stable pH. 3. Column Care: Use a guard column and ensure proper column washing and storage procedures are followed. Multiple injections of extracted samples can lead to retention time shifts if the column is not properly maintained.
--------------------------------	--	--

---

## Frequently Asked Questions (FAQs)

Q1: What are the key challenges in analyzing glyphosate and AMPA?

A1: The primary challenges stem from their physicochemical properties. Both are highly polar, zwitterionic molecules, which leads to poor retention on conventional reversed-phase HPLC columns.[1][6] They also have a strong tendency to chelate with metal ions, which can cause poor peak shape and reproducibility issues.[1][3][10] Furthermore, they lack a chromophore, making UV detection difficult without a derivatization step.[3]

Q2: Is derivatization necessary for glyphosate analysis?

A2: Not always, but it is a common strategy to overcome analytical challenges. Derivatization with reagents like FMOC-Cl increases the hydrophobicity of glyphosate and AMPA, which improves their retention on reversed-phase columns.[6][10] It also adds a fluorescent or chromophoric group, enhancing detection sensitivity for HPLC-UV/Fluorescence methods.[3][12] However, direct analysis of underivatized glyphosate is possible and preferred for

simplicity, typically using LC-MS/MS with specialized columns like HILIC or mixed-mode columns.[\[1\]](#)[\[6\]](#)

Q3: What are typical parameters to vary during a robustness test for a glyphosate analysis method?

A3: A robustness test evaluates the method's resilience to small, deliberate variations in experimental parameters. Typical parameters to investigate include:

- pH of the mobile phase/extraction solvent: pH can significantly affect the ionization state and retention of glyphosate.[\[9\]](#)
- Mobile phase composition: Minor changes in the percentage of organic solvent.
- Column temperature.
- Flow rate.
- Derivatization time and temperature (if applicable).[\[9\]](#)

The impact of these variations on results such as peak area, retention time, and resolution is then assessed.

Q4: How does one perform a ruggedness test?

A4: Ruggedness testing assesses the reproducibility of the method under different conditions, simulating real-world variations. This typically involves comparing results obtained by:

- Different analysts.
- Different instruments.
- Different batches of reagents or columns.
- Performing the analysis on different days.[\[13\]](#)

The goal is to ensure the method provides consistent and reliable results when transferred between labs or operators.

Q5: What are the advantages of using LC-MS/MS for glyphosate analysis?

A5: LC-MS/MS is the preferred technique for its high sensitivity and selectivity.[8] It allows for the direct analysis of underivatized glyphosate, simplifying sample preparation.[6] The use of tandem mass spectrometry (MS/MS) provides structural confirmation and allows for quantification at very low levels (ng/L or µg/kg), even in complex matrices like food and soil.[1][14] The use of stable isotope-labeled internal standards with LC-MS/MS is considered the gold standard for compensating for matrix effects and ensuring high accuracy.[7]

## Method Ruggedness and Robustness Data

The following table summarizes typical acceptance criteria and observed variations from method validation and robustness studies for glyphosate analysis.

Parameter	Typical Acceptance Criteria (e.g., SANTE guidelines)	Example Robustness Variation	Observed Effect
Recovery (Accuracy)	70-120% <a href="#">[5]</a> <a href="#">[15]</a>	pH of extraction solvent: 7.5 vs. 8.5	A study noted that pH 8 significantly affects glyphosate recovery. <a href="#">[9]</a>
Precision (RSD)	≤ 20% <a href="#">[6]</a> <a href="#">[15]</a> <a href="#">[16]</a>	Derivatization time: 30 min vs. 60 min	Derivatization time was found to affect all analytes (glyphosate, AMPA, glufosinate). <a href="#">[9]</a>
Linearity (R <sup>2</sup> )	> 0.99 <a href="#">[5]</a> <a href="#">[14]</a>	Mobile phase organic content: ± 2%	Minimal impact on R <sup>2</sup> values.
Limit of Quantification (LOQ)	Method dependent, often in the low µg/kg or µg/L range. <a href="#">[6]</a> <a href="#">[14]</a> <a href="#">[15]</a>	Column Temperature: 35°C vs. 45°C	Minor shifts in retention time, but typically no significant change in LOQ.

## Experimental Protocols

## Protocol 1: Underivatized Glyphosate and AMPA Analysis by LC-MS/MS

This method is suitable for water samples and is based on direct injection.

- Sample Preparation:
  - Filter the water sample through a 0.45  $\mu\text{m}$  filter.
  - To an aliquot of the sample, add an internal standard solution (e.g., Glyphosate- $^{13}\text{C}_2,^{15}\text{N}$ ).  
[7]
  - To mitigate metal chelation, especially in hard water, add a small volume of EDTA solution to the sample.[4]
- LC-MS/MS Analysis:
  - Liquid Chromatography:
    - Column: Use a mixed-mode column (e.g., reversed-phase and weak anion-exchange) or a HILIC column suitable for polar analytes.[4]
    - Mobile Phase: A common mobile phase consists of an aqueous solution with a small percentage of organic solvent (e.g., acetonitrile) and an acid modifier like formic acid.[1]  
[7]
    - Gradient: A gradient elution is typically used to separate the analytes.
  - Mass Spectrometry:
    - Ionization: Employ a tandem mass spectrometer with an electrospray ionization (ESI) source, typically operated in negative ion mode.[7]
    - Detection: Monitor specific precursor-to-product ion transitions in Multiple Reaction Monitoring (MRM) mode for both the analyte and the internal standard.[7]
- Quantification:

- Construct a calibration curve by plotting the ratio of the peak area of the analyte to the peak area of the internal standard against the concentration of the calibration standards. [7]
- Determine the concentration of the analyte in the samples from the calibration curve.

## Protocol 2: Derivatized Glyphosate and AMPA Analysis by LC-MS/MS

This method is often used for complex matrices like food or soil.

- Sample Extraction (QuPPE Method Example):
  - Weigh a homogenized sample (e.g., 10 g) into a centrifuge tube.
  - Add water and an internal standard solution.
  - Add methanol containing 1% formic acid, shake vigorously, and centrifuge.
  - The supernatant can be further cleaned up using Solid-Phase Extraction (SPE) if necessary.[6]
- Derivatization:
  - Take an aliquot of the extract and adjust the pH to alkaline conditions (e.g., pH 9) using a borate buffer.[3][5]
  - Add a solution of 9-fluorenylmethylchloroformate (FMOC-Cl) in acetonitrile.[6]
  - Allow the reaction to proceed for a specified time (e.g., 4 hours) at a controlled temperature.[3]
  - Quench the reaction if necessary.
- LC-MS/MS Analysis:
  - Liquid Chromatography:

- Column: A standard C18 or C8 reversed-phase column can be used for the less polar Fmoc derivatives.[6]
- Mobile Phase: A typical mobile phase would be a gradient of water and acetonitrile/methanol with an additive like ammonium formate or formic acid.
- Mass Spectrometry:
  - Ionization: ESI in either positive or negative mode can be used.[6]
  - Detection: Monitor the specific MRM transitions for the Fmoc-derivatized glyphosate, AMPA, and their internal standards.
- Quantification:
  - Follow the same quantification procedure as described in Protocol 1.

## Visualizations

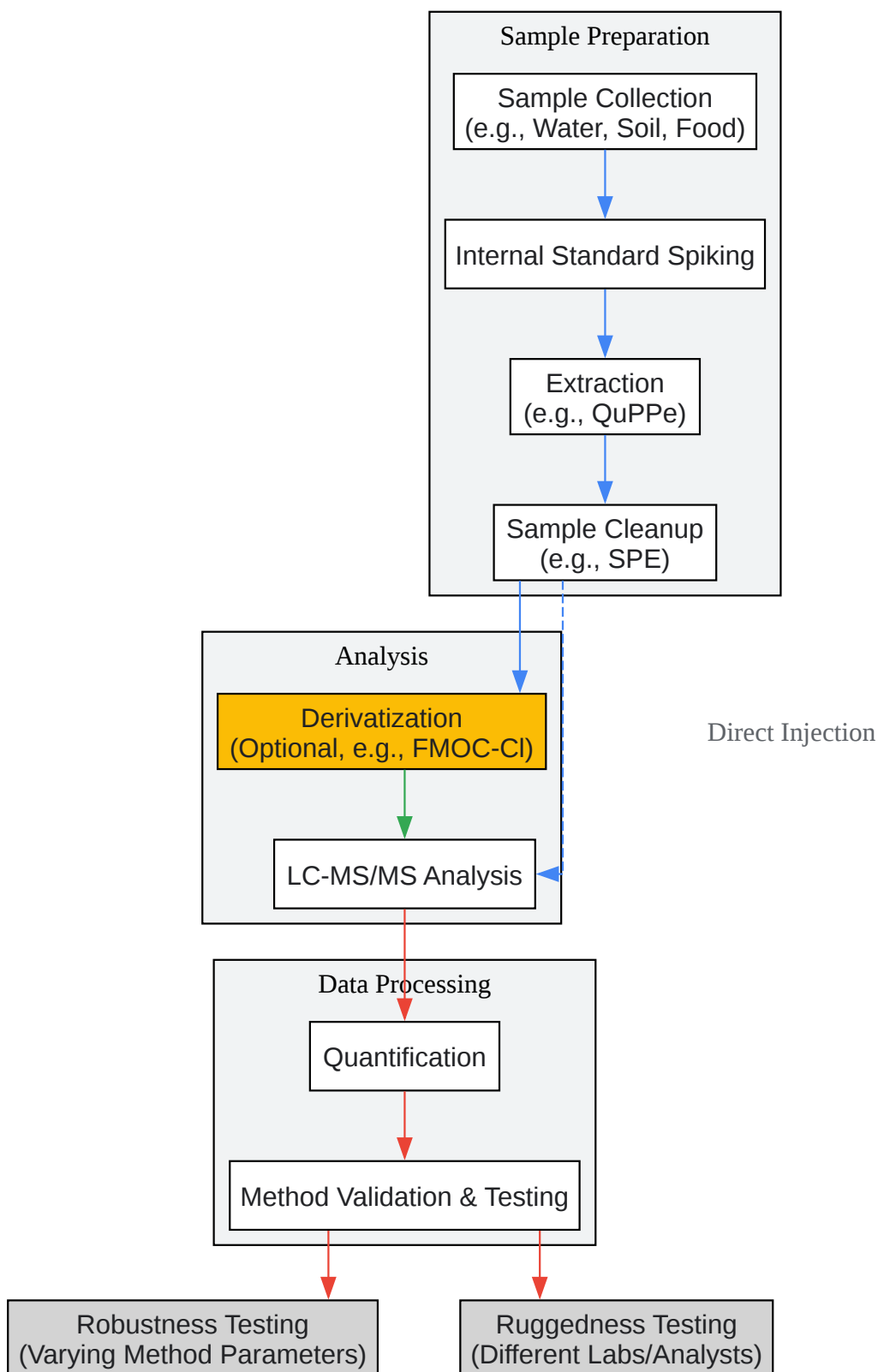

[Click to download full resolution via product page](#)

Caption: General experimental workflow for glyphosate analysis and method validation.

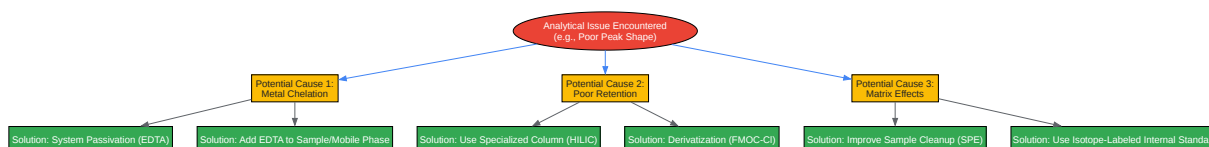

[Click to download full resolution via product page](#)

Caption: Logical workflow for troubleshooting common issues in glyphosate analysis.

### Need Custom Synthesis?

BenchChem offers custom synthesis for rare earth carbides and specific isotopic labeling.

Email: [info@benchchem.com](mailto:info@benchchem.com) or [Request Quote Online](#).

## References

- 1. [agilent.com](http://agilent.com) [[agilent.com](http://agilent.com)]
- 2. Glyphosate is not reproducible - Chromatography Forum [[chromforum.org](http://chromforum.org)]
- 3. [pubs.acs.org](http://pubs.acs.org) [[pubs.acs.org](http://pubs.acs.org)]
- 4. Development of a sensitive direct injection LC-MS/MS method for the detection of glyphosate and aminomethylphosphonic acid (AMPA) in hard waters - PMC [[pmc.ncbi.nlm.nih.gov](http://pmc.ncbi.nlm.nih.gov)]
- 5. [fimek.edu.rs](http://fimek.edu.rs) [[fimek.edu.rs](http://fimek.edu.rs)]
- 6. [mdpi.com](http://mdpi.com) [[mdpi.com](http://mdpi.com)]
- 7. [benchchem.com](http://benchchem.com) [[benchchem.com](http://benchchem.com)]
- 8. [benchchem.com](http://benchchem.com) [[benchchem.com](http://benchchem.com)]

- [9. researchgate.net \[researchgate.net\]](#)
- [10. alsenvironmental.co.uk \[alsenvironmental.co.uk\]](#)
- [11. Glyphosate analysis | Department of Industry Science and Resources \[industry.gov.au\]](#)
- [12. New Standardized Procedure to Extract Glyphosate and Aminomethylphosphonic Acid from Different Matrices: A Kit for HPLC-UV Detection - PMC \[pmc.ncbi.nlm.nih.gov\]](#)
- [13. glyphosate.eu \[glyphosate.eu\]](#)
- [14. researchgate.net \[researchgate.net\]](#)
- [15. Method of Glyphosate, AMPA, and Glufosinate Ammonium Determination in Beebread by Liquid Chromatography—Tandem Mass Spectrometry after Molecularly Imprinted Solid-Phase Extraction - PMC \[pmc.ncbi.nlm.nih.gov\]](#)
- [16. www2.gov.bc.ca \[www2.gov.bc.ca\]](#)
- [To cite this document: BenchChem. \[Method ruggedness and robustness testing for Glyphosate monoammonium analysis\]. BenchChem, \[2026\]. \[Online PDF\]. Available at: \[https://www.benchchem.com/product/b12279329/docs#method-ruggedness-and-robustness-testing-for-glyphosate-monoammonium-analysis\]](#)

---

### Disclaimer & Data Validity:

The information provided in this document is for Research Use Only (RUO) and is strictly not intended for diagnostic or therapeutic procedures. While BenchChem strives to provide accurate protocols, we make no warranties, express or implied, regarding the fitness of this product for every specific experimental setup.

**Technical Support:** The protocols provided are for reference purposes. Unsure if this reagent suits your experiment?

**Need Industrial/Bulk Grade?** [Request Custom Synthesis Quote](#)

# BenchChem

Our mission is to be the trusted global source of essential and advanced chemicals, empowering scientists and researchers to drive progress in science and industry.

## Contact

Address: 3281 E Guasti Rd

Ontario, CA 91761, United States

Phone: (601) 213-4426

Email: [info@benchchem.com](mailto:info@benchchem.com)

[Contact our Ph.D. Support Team for a compatibility check](#)