

# Introduction: The Strategic Imperative for Metabolic Stability in Drug Design

**Author:** BenchChem Technical Support Team. **Date:** May 2026

## Compound of Interest

Compound Name: 6,7-Difluoro-3-iodo-1-methyl-1H-indazole

Cat. No.: B11836527

[Get Quote](#)

In the landscape of modern medicinal chemistry, heterocyclic scaffolds are foundational, present in over 85% of all biologically active compounds.[1] Their prevalence stems from their ability to present functional groups in precise three-dimensional arrangements, enabling potent and selective interactions with biological targets. However, a pharmacologically active molecule is only viable as a therapeutic if it possesses a suitable pharmacokinetic profile. A critical determinant of this profile is metabolic stability—the molecule's resistance to biotransformation by the body's enzymatic machinery.[2]

Poor metabolic stability can lead to rapid clearance, low bioavailability, and insufficient drug exposure at the target site, rendering an otherwise potent compound ineffective.[3] Conversely, excessively high stability can cause drug accumulation and potential toxicity.[3] The strategic incorporation of fluorine atoms has become a cornerstone of drug design to address these challenges.[4][5] The carbon-fluorine bond is the strongest single bond in organic chemistry, making it highly resistant to oxidative metabolism.[6]

This guide provides an in-depth analysis of the metabolic stability conferred by a specific and powerful structural motif: the 6,7-difluoro substitution on heterocyclic cores. We will explore the underlying physicochemical principles, the key metabolic pathways involved, the definitive

experimental workflows for assessment, and the strategic implications for drug development professionals.

## Section 1: The Physicochemical Impact of 6,7-Difluoro Substitution

The introduction of fluorine atoms at the 6 and 7 positions of a heterocyclic core is not merely an arbitrary substitution; it is a deliberate tactic to fundamentally alter the molecule's susceptibility to metabolism through several key mechanisms.

- **Direct Blocking of Metabolic "Soft Spots":** The primary advantage is the replacement of metabolically labile carbon-hydrogen (C-H) bonds with robust carbon-fluorine (C-F) bonds. Aromatic hydroxylation is a common metabolic pathway catalyzed by Cytochrome P450 (CYP) enzymes. By occupying these positions, the fluorine atoms act as shields, physically blocking this route of oxidative attack.[\[6\]](#)[\[7\]](#)[\[8\]](#)
- **Electronic Deactivation of the Aromatic System:** Fluorine is the most electronegative element, exerting a powerful electron-withdrawing effect. The presence of two fluorine atoms significantly lowers the electron density of the heterocyclic ring system.[\[9\]](#)[\[10\]](#) Since CYP-mediated oxidation typically targets electron-rich sites, this electronic deactivation makes the entire core less prone to metabolic degradation.[\[10\]](#)
- **Modulation of Physicochemical Properties:** Fluorine substitution can influence a molecule's lipophilicity (logP), a critical factor in how a drug interacts with metabolizing enzymes. While a single fluorine atom often causes a modest increase in lipophilicity, strategic difluorination can be used to fine-tune this property to optimize the balance between membrane permeability and metabolic susceptibility.[\[4\]](#)[\[11\]](#)

## Section 2: Core Metabolic Pathways for Fluorinated Heterocycles

While the 6,7-difluoro motif provides a strong metabolic shield, the entire molecule is not inert. Metabolism will be redirected to other, now more susceptible, sites. Understanding these alternative pathways is crucial for predicting a compound's metabolic fate. The primary

enzymes responsible for this are the Cytochrome P450 (CYP) superfamily, which catalyze the majority of Phase I oxidative metabolism.[12]

Common Metabolic Transformations Include:

- Oxidation of Other Substituents: Alkyl groups attached to the heterocycle or its nitrogens can undergo hydroxylation.
- N-Dealkylation: If the heterocycle contains N-alkyl substituents, these are common sites for oxidative removal, a well-documented pathway for many heterocyclic drugs.[13][14]
- Oxidation of the Heterocyclic Core: While the 6,7-difluoro positions are protected, other positions on the ring system may still be susceptible to oxidation, depending on the specific heterocycle.
- Metabolic Defluorination: Although the aryl C-F bond is exceptionally stable, metabolic cleavage to release a fluoride ion can occur, though it is generally a minor pathway for aromatic fluorides compared to aliphatic ones.[4][9]

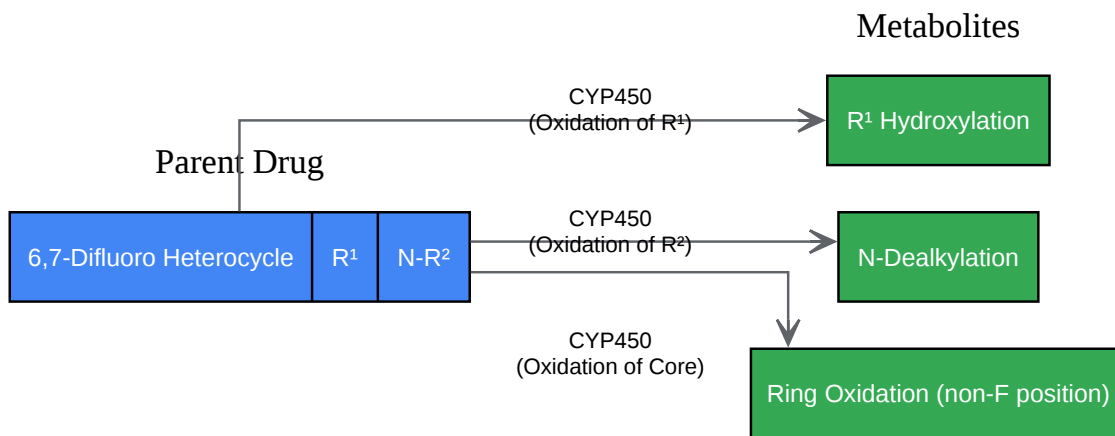

Potential Metabolic Pathways

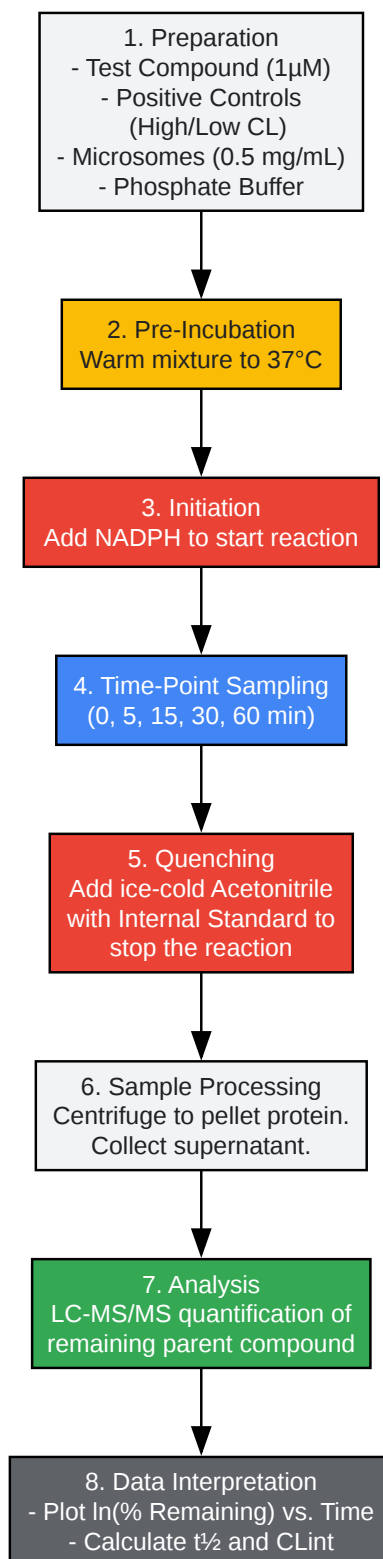

Workflow for In Vitro Metabolic Stability Assay

[Click to download full resolution via product page](#)

Caption: Standard workflow for a liver microsomal stability assay.

# Detailed Experimental Protocol: Liver Microsomal Stability Assay

## 1. Reagent Preparation:

- **Test Compound Stock:** Prepare a 1 mM stock solution of the 6,7-difluoro substituted heterocycle in DMSO.
- **Control Compounds:** Prepare 1 mM stocks of a high-clearance compound (e.g., Verapamil) and a low-clearance compound (e.g., Warfarin). The inclusion of these controls is critical to validate the activity of the microsomal batch and the overall assay performance.
- **Microsome Suspension:** Thaw pooled human liver microsomes (e.g., from a commercial supplier) on ice and dilute to a final concentration of 0.5 mg/mL in 0.1 M phosphate buffer (pH 7.4).
- **NADPH Stock:** Prepare a fresh solution of NADPH regenerating system or NADPH stock solution in 0.1 M phosphate buffer. The cofactor NADPH is essential for the catalytic activity of CYP enzymes.

## 2. Incubation Procedure:

- Add the test compound or control compound to the microsomal suspension to achieve a final substrate concentration of 1  $\mu$ M.
- Pre-incubate the mixture at 37°C for 5 minutes to allow the compound to equilibrate with the enzymes.
- Initiate the metabolic reaction by adding the pre-warmed NADPH solution. A parallel incubation without NADPH serves as a negative control to assess non-enzymatic degradation.

## 3. Time-Point Sampling and Quenching:

- At specified time points (e.g., 0, 5, 15, 30, 45, and 60 minutes), withdraw an aliquot of the reaction mixture.
- Immediately quench the reaction by adding the aliquot to a tube containing 2-3 volumes of ice-cold acetonitrile. The acetonitrile serves to precipitate the proteins and halt all enzymatic activity. This solution should also contain an internal standard for accurate quantification via LC-MS/MS.

## 4. Sample Analysis:

- Centrifuge the quenched samples to pellet the precipitated proteins.
- Transfer the supernatant to a new plate or vial for analysis.
- Quantify the remaining concentration of the parent compound at each time point using a validated LC-MS/MS (Liquid Chromatography-Tandem Mass Spectrometry) method.

#### 5. Data Analysis:

- Determine the percentage of the parent compound remaining at each time point relative to the 0-minute sample.
- Plot the natural logarithm (ln) of the % remaining versus time. The slope of the resulting line (k) represents the elimination rate constant.
- Calculate the in vitro half-life ( $t_{1/2}$ ) and intrinsic clearance (CL<sub>int</sub>) using the following equations:
  - $t_{1/2} = 0.693 / k$
  - $CL_{int} (\mu\text{L}/\text{min}/\text{mg protein}) = (0.693 / t_{1/2}) * (1 / \text{mg}/\text{mL microsomal protein})$

## Section 4: Strategic Implications and Advanced Approaches

The use of a 6,7-difluoro substitution is a powerful, proactive strategy to design metabolically robust molecules. However, drug discovery is an iterative process. If a promising compound still exhibits metabolic liabilities at other sites, further modifications can be employed.

- **Scaffold Hopping:** If a particular heterocyclic core, despite difluorination, presents other metabolic issues, it can be replaced with a bioisosteric but more stable ring system. For example, replacing an electron-rich ring with an electron-deficient one (like a pyridine) can further enhance stability. [10]\*
- **Deuteration:** Replacing C-H bonds at a known metabolic soft spot with C-D (deuterium) bonds can slow the rate of metabolism due to the kinetic isotope effect. This is a more subtle modification that is less likely to impact pharmacological activity.
- **Steric Shielding:** Introducing bulky functional groups near a remaining metabolic hot spot can physically block the access of metabolizing enzymes, thereby improving stability. [8]

## Conclusion

The strategic implementation of 6,7-difluoro substitution on heterocyclic cores represents a highly effective and mechanistically sound approach to enhancing metabolic stability in drug

candidates. By directly blocking and electronically deactivating common sites of oxidative metabolism, this motif forces biotransformation to alternative, often slower, pathways. This leads to improved pharmacokinetic properties such as increased half-life and oral bioavailability. [15]A comprehensive evaluation using a tiered in vitro approach, progressing from microsomes to hepatocytes, is essential for building a complete metabolic profile. By integrating these foundational principles and robust experimental protocols, researchers and drug development professionals can more efficiently design and select compounds with a higher probability of clinical success.

## References

- Park, B. K., & Kitteringham, N. R. (1994). Effects of Fluorine Substitution on Drug Metabolism: Pharmacological and Toxicological Implications. *Drug Metabolism Reviews*, 26(3), 605-43.
- Park, B. K., Kitteringham, N. R., & O'Neill, P. M. (2001). METABOLISM OF FLUORINE-CONTAINING DRUGS. *Annual Review of Pharmacology and Toxicology*, 41, 443-470.
- WuXi AppTec. (2023). Metabolic Stability in Drug Development: 5 Assays. WuXi AppTec Content Hub.
- Creative Bioarray. In Vitro Metabolic Stability.
- Eurofins Discovery. Metabolic Stability Services. Eurofins Discovery.
- Creative Biolabs. Drug Metabolic Stability Analysis Service.
- Lafortune, E. A., & Meanwell, N. A. (2012). Mitigating Heterocycle Metabolism in Drug Discovery. *Journal of Medicinal Chemistry*, 55(13), 6002-20.
- Baranczewski, P., Stańczak, A., Sundberg, K., et al. (2006). Introduction to in vitro estimation of metabolic stability and drug interactions of new chemical entities in drug discovery and development. *Pharmacological Reports*, 58(4), 453-72.
- SciSpace. (2000). Metabolism of fluorine-containing drugs. SciSpace.
- Dalvie, D. K., & Sharma, R. (2020). On the Metabolic Stability of Fluorinated Small Molecules: A Physical Organic Chemistry Perspective. *ACS Medicinal Chemistry Letters*, 11(4), 384-390.
- Meanwell, N. A. (2018). Improving Drug Efficacy: The Role of Heterocyclic Frameworks in Enhancing Selectivity and Metabolic Stability. *International Journal of Pharmaceutical and Phytopharmacological Research*.
- J. C. C. (2024).
- Stratton, C. F., & Rovis, T. (2019). Scaffold-hopping as a strategy to address metabolic liabilities of aromatic compounds. *MedChemComm*, 10(12), 2095-2107.
- Di, L. (2014). Improving the decision-making process in the structural modification of drug candidates Part I: Enhancing Metabolic Stability. *New England Drug Metabolism Discussion*

Group.

- Słoczyńska, K., et al. (2019). Metabolic stability and its role in the discovery of new chemical entities. *Acta Pharmaceutica*, 69(3), 345-361.
- Øiestad, E. L., et al. (2020). Metabolite Profiling of Ortho-, Meta- and Para-Fluorofentanyl by Hepatocytes and High-Resolution Mass Spectrometry. *Journal of Analytical Toxicology*, 44(3), 249-259.
- Øiestad, E. L., et al. (2020). Metabolite Profiling of Ortho-, Meta- and Para-Fluorofentanyl by Hepatocytes and High-Resolution Mass Spectrometry. *Journal of Analytical Toxicology*, 44(3), 249-259.
- Open Library Publishing Platform. Drug Modifications to Improve Stability – An Introduction to Medicinal Chemistry & Molecular Recognition.
- Bisht, R., & Singh, R. (2020). Prescribed drugs containing nitrogen heterocycles: an overview. *RSC Advances*, 10(63), 38225-38269.

#### *Need Custom Synthesis?*

*BenchChem offers custom synthesis for rare earth carbides and specific isotopic labeling.*

*Email: [info@benchchem.com](mailto:info@benchchem.com) or [Request Quote Online](#).*

## Sources

- [1. Prescribed drugs containing nitrogen heterocycles: an overview - PMC \[pmc.ncbi.nlm.nih.gov\]](#)
- [2. researchgate.net \[researchgate.net\]](#)
- [3. Drug Metabolic Stability Analysis Service - Creative Biolabs \[creative-biolabs.com\]](#)
- [4. annualreviews.org \[annualreviews.org\]](#)
- [5. scispace.com \[scispace.com\]](#)
- [6. Drug Modifications to Improve Stability – An Introduction to Medicinal Chemistry & Molecular Recognition \[ecampusontario.pressbooks.pub\]](#)
- [7. pubs.acs.org \[pubs.acs.org\]](#)
- [8. ijppr.humanjournals.com \[ijppr.humanjournals.com\]](#)
- [9. tandfonline.com \[tandfonline.com\]](#)
- [10. Scaffold-hopping as a strategy to address metabolic liabilities of aromatic compounds - PMC \[pmc.ncbi.nlm.nih.gov\]](#)

- [11. encyclopedia.pub \[encyclopedia.pub\]](#)
- [12. On the Metabolic Stability of Fluorinated Small Molecules: A Physical Organic Chemistry Perspective - PMC \[pmc.ncbi.nlm.nih.gov\]](#)
- [13. pdfs.semanticscholar.org \[pdfs.semanticscholar.org\]](#)
- [14. Metabolite Profiling of Ortho-, Meta- and Para-Fluorofentanyl by Hepatocytes and High-Resolution Mass Spectrometry - PubMed \[pubmed.ncbi.nlm.nih.gov\]](#)
- [15. dda.creative-bioarray.com \[dda.creative-bioarray.com\]](#)
- To cite this document: BenchChem. [Introduction: The Strategic Imperative for Metabolic Stability in Drug Design]. BenchChem, [2026]. [Online PDF]. Available at: [\[https://www.benchchem.com/product/b11836527/docs#introduction-the-strategic-imperative-for-metabolic-stability-in-drug-design\]](https://www.benchchem.com/product/b11836527/docs#introduction-the-strategic-imperative-for-metabolic-stability-in-drug-design)

---

#### Disclaimer & Data Validity:

The information provided in this document is for Research Use Only (RUO) and is strictly not intended for diagnostic or therapeutic procedures. While BenchChem strives to provide accurate protocols, we make no warranties, express or implied, regarding the fitness of this product for every specific experimental setup.

**Technical Support:** The protocols provided are for reference purposes. Unsure if this reagent suits your experiment?

**Need Industrial/Bulk Grade?** [Request Custom Synthesis Quote](#)

## BenchChem

Our mission is to be the trusted global source of essential and advanced chemicals, empowering scientists and researchers to drive progress in science and industry.

#### Contact

Address: 3281 E Guasti Rd  
Ontario, CA 91761, United States  
Phone: (601) 213-4426  
Email: [info@benchchem.com](mailto:info@benchchem.com)

Contact our Ph.D. Support Team for a compatibility check