

Technical Support Center: Troubleshooting Distorted Protein Migration

Author: BenchChem Technical Support Team. **Date:** December 2025

Compound of Interest

Compound Name: ML042

Cat. No.: B1227343

[Get Quote](#)

This guide provides researchers, scientists, and drug development professionals with a comprehensive resource for troubleshooting distorted protein migration during gel electrophoresis, with a focus on buffer-related issues. While this guide addresses issues that may arise with any buffer system, it is structured to be particularly helpful if you are experiencing problems with a buffer you know as **ML042**. Please note that "ML042 buffer" is not a universally recognized standard buffer formulation; therefore, the principles and protocols provided here are based on common electrophoresis buffer systems like Tris-Glycine-SDS and can be adapted to your specific needs.

Frequently Asked Questions (FAQs)

Q1: Why are my protein bands smiling (curved upwards at the edges)?

"Smiling" bands are typically caused by uneven heat distribution across the gel during electrophoresis. The center of the gel becomes hotter than the edges, causing proteins in the central lanes to migrate faster.

Potential Causes & Solutions:

- **Inappropriate Voltage/Power Settings:** Running the gel at too high a voltage generates excess heat.

- Solution: Reduce the voltage and run the gel for a longer duration. Consider running the gel in a cold room or an ice bath to help dissipate heat.[1]
- Incorrect Buffer Concentration: Using a buffer that is too concentrated can increase conductivity and heat generation.
 - Solution: Double-check the concentration of your buffer stock and ensure it is diluted correctly. Prepare fresh buffer if you suspect contamination or incorrect formulation.[2][3]
- Poorly Polymerized Gel: Incomplete polymerization can lead to an inconsistent gel matrix and uneven current flow.
 - Solution: Ensure that the gel has had adequate time to polymerize completely. Using fresh ammonium persulfate (APS) and TEMED is crucial for proper polymerization.[3]

Q2: What causes my protein bands to frown (curved downwards at the edges)?

"Frowning" bands are less common than smiling but can also be attributed to uneven migration, often due to issues with the gel polymerization or sample loading.

Potential Causes & Solutions:

- Uneven Gel Polymerization: If the top of the resolving gel polymerizes unevenly, it can create a distorted starting line for protein separation.
 - Solution: Ensure the resolving gel is perfectly level before it polymerizes. Overlaying the gel with isopropanol or water can help create a sharp, even interface.
- Overloading of Protein: Loading too much protein into a well can cause the band to spread and distort.[4]
 - Solution: Reduce the amount of protein loaded in each well. Perform a protein concentration assay to ensure you are loading an appropriate amount.
- Buffer Depletion: Reusing running buffer multiple times can lead to ion depletion, affecting the electric field.

- Solution: Use fresh running buffer for each experiment to ensure consistent ion concentration.

Q3: Why are my protein bands distorted or skewed?

Skewed or distorted bands that are not uniformly smiling or frowning can be caused by a variety of factors related to the sample, the gel, or the electric field.

Potential Causes & Solutions:

- High Salt Concentration in the Sample: Excess salt in the protein sample can disrupt the local electric field, causing bands to migrate unevenly.[4]
 - Solution: Desalt the protein sample using dialysis or a desalting column before adding the sample buffer.
- Insoluble Particles in the Sample: Precipitated protein or other debris in the sample can block the pores of the gel, leading to streaking and distortion.
 - Solution: Centrifuge your samples after boiling and before loading to pellet any insoluble material.
- Improperly Prepared Buffer: Using a running buffer with an incorrect pH or ionic strength can lead to poor protein stacking and separation.[5]
 - Solution: Prepare fresh buffer, ensuring that the pH is correct and that all components are fully dissolved. Do not adjust the pH of Tris-Glycine-SDS running buffer with acid, as this can introduce chloride ions that interfere with migration.[6][7]

Quantitative Data Summary

The following table provides a summary of key quantitative parameters for successful SDS-PAGE.

Parameter	Recommendation	Notes
1X Tris-Glycine-SDS Running Buffer	25 mM Tris, 192 mM Glycine, 0.1% SDS, pH ~8.3	Prepared by diluting a 10X stock. Do not adjust the pH of the 1X buffer. [8] [9]
Voltage (Mini Gel)	Stacking: 50-75 V; Resolving: 100-150 V	Running at a lower voltage for a longer time generally improves resolution. [10] [11]
Current (Mini Gel)	~20 mA per gel during stacking, ~30-40 mA per gel during resolving	If running at constant current, monitor the voltage to prevent overheating. [10]
Protein Load (Coomassie Blue Stain)	2-4 µg for a purified protein; 20-50 µg for a complex mixture	Overloading can cause band distortion. [12]
Protein Load (Silver Stain)	1-10 ng for a purified protein	Silver staining is significantly more sensitive than Coomassie. [13] [14]

Experimental Protocols

Preparation of 10X Tris-Glycine-SDS Running Buffer

This protocol provides a standard method for preparing a 10X stock solution of Tris-Glycine-SDS running buffer.

Materials:

- Tris base
- Glycine
- Sodium Dodecyl Sulfate (SDS)
- Deionized water
- Graduated cylinder

- Magnetic stirrer and stir bar
- pH meter (optional, for verification)

Procedure:

- To prepare 1 liter of 10X running buffer, weigh out 30.3 g of Tris base and 144.1 g of glycine. [8]
- Add the Tris base and glycine to a beaker containing approximately 800 mL of deionized water.
- Stir the solution until all the components are completely dissolved.
- Weigh out 10 g of SDS and add it to the solution. Continue stirring until the SDS is fully dissolved. Be careful to avoid excessive foaming. [15]
- Transfer the solution to a 1 L graduated cylinder and add deionized water to bring the final volume to 1 liter.
- The pH of the 10X buffer should be approximately 8.3 and does not require adjustment. [9]
- Store the 10X running buffer at room temperature. If the SDS precipitates out of solution, gently warm the buffer to redissolve it before use. [8]
- To prepare 1X running buffer, dilute the 10X stock 1:10 with deionized water (e.g., 100 mL of 10X buffer + 900 mL of deionized water).

Visual Troubleshooting Guide

The following diagrams illustrate the logical workflow for troubleshooting distorted protein migration and the potential signaling pathways that can be affected by experimental artifacts.

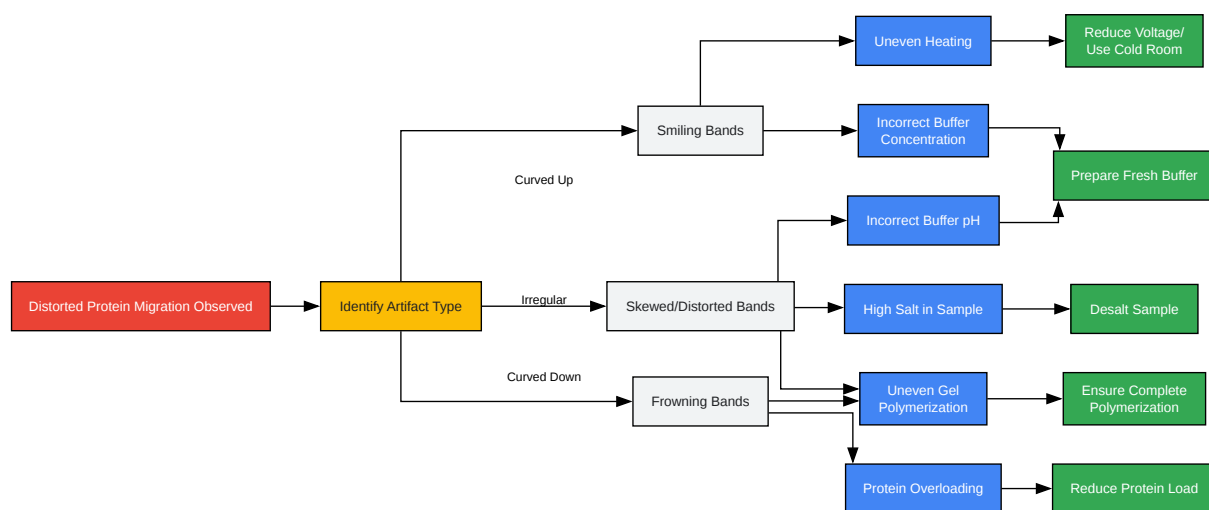

[Click to download full resolution via product page](#)

Caption: Troubleshooting workflow for distorted protein migration.

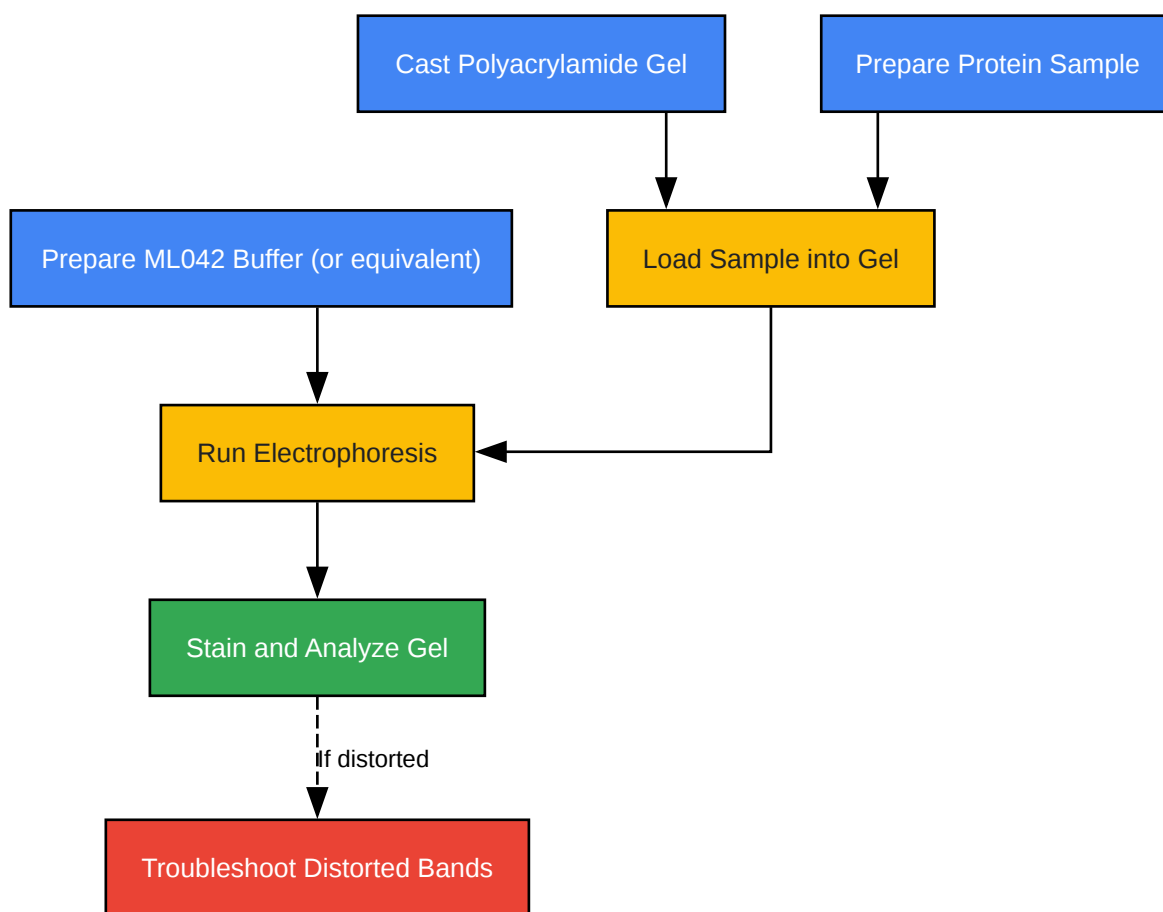

[Click to download full resolution via product page](#)

Caption: Standard experimental workflow for SDS-PAGE.

Need Custom Synthesis?

BenchChem offers custom synthesis for rare earth carbides and specific isotopic labeling.

Email: info@benchchem.com or [Request Quote Online](#).

References

- 1. Running SDS-PAGE - Powers Wiki [bionmr.unl.edu]
- 2. Protein Gel Electrophoresis Tips and Troubleshooting Guide [aldrin.tripod.com]
- 3. researchgate.net [researchgate.net]

- 4. Protein Gel 1D Electrophoresis Support—Troubleshooting | Thermo Fisher Scientific - US [thermofisher.com]
- 5. Shopping [edvotek.com]
- 6. serva.de [serva.de]
- 7. researchgate.net [researchgate.net]
- 8. anilocus.org [anilocus.org]
- 9. laboratorynotes.com [laboratorynotes.com]
- 10. researchgate.net [researchgate.net]
- 11. researchgate.net [researchgate.net]
- 12. m.youtube.com [m.youtube.com]
- 13. youtube.com [youtube.com]
- 14. youtube.com [youtube.com]
- 15. SDS-PAGE SDS Running Buffer (10x) Preparation and Recipe | AAT Bioquest [aatbio.com]
- To cite this document: BenchChem. [Technical Support Center: Troubleshooting Distorted Protein Migration]. BenchChem, [2025]. [Online PDF]. Available at: [https://www.benchchem.com/product/b1227343#ml042-buffer-causing-distorted-protein-migration]

Disclaimer & Data Validity:

The information provided in this document is for Research Use Only (RUO) and is strictly not intended for diagnostic or therapeutic procedures. While BenchChem strives to provide accurate protocols, we make no warranties, express or implied, regarding the fitness of this product for every specific experimental setup.

Technical Support: The protocols provided are for reference purposes. Unsure if this reagent suits your experiment? [[Contact our Ph.D. Support Team for a compatibility check](#)]

Need Industrial/Bulk Grade? [Request Custom Synthesis Quote](#)

BenchChem

Our mission is to be the trusted global source of essential and advanced chemicals, empowering scientists and researchers to drive progress in science and industry.

Contact

Address: 3281 E Guasti Rd
Ontario, CA 91761, United States
Phone: (601) 213-4426
Email: info@benchchem.com