

Application Notes and Protocols for F-PE3 in Primary Neuron Cultures

Author: BenchChem Technical Support Team. **Date:** April 2026

Compound of Interest

Compound Name: *Fura-PE3*

Cat. No.: *B1227955*

[Get Quote](#)

For Researchers, Scientists, and Drug Development Professionals

Introduction

Fura-PE3 is a ratiometric calcium indicator that is an analog of Fura-2. It is designed to be more resistant to leakage from cells, making it particularly well-suited for long-term calcium imaging studies in primary neuron cultures. Like Fura-2, **Fura-PE3** exhibits a shift in its fluorescence excitation spectrum upon binding to Ca^{2+} , allowing for the determination of intracellular calcium concentrations by measuring the ratio of fluorescence intensities at two different excitation wavelengths.[1] This ratiometric measurement corrects for variations in dye concentration, illumination intensity, and optical path length, providing more accurate and reliable data.[1][2]

These application notes provide a comprehensive guide to using **Fura-PE3** AM for calcium imaging in primary neuron cultures, covering everything from the initial cell culture to data analysis and troubleshooting.

Quantitative Data Summary

The following tables summarize key quantitative parameters for using **Fura-PE3** in primary neuron cultures. These values are derived from protocols for the closely related Fura-2 AM and should be optimized for your specific cell type and experimental conditions.

Parameter	Recommended Value	Notes
Fura-PE3 AM Stock Solution	1-4 mM in dry DMSO	Prepare fresh for each experiment.[3] Vortex thoroughly for at least 10 minutes to ensure the dye is fully dissolved.[3] Pluronic F-127 (20% in DMSO) can be added to the stock solution to aid in dye loading.[3]
Working Concentration	1-5 μ M	The optimal concentration should be determined empirically. Higher concentrations can lead to cytotoxicity and calcium buffering.
Incubation Time	30-60 minutes	Longer incubation times may be required for complete de-esterification but can also increase the risk of cytotoxicity.[4]
Incubation Temperature	37°C	Incubation at 37°C generally facilitates faster loading and de-esterification.[4]
Excitation Wavelengths	340 nm (Ca^{2+} -bound) and 380 nm (Ca^{2+} -free)	These are the standard excitation wavelengths for ratiometric imaging with Fura dyes.[1][2]
Emission Wavelength	~510 nm	The emission peak for both the Ca^{2+} -bound and Ca^{2+} -free forms of the dye.[1][2]

Spectral Properties	Wavelength (nm)
Excitation (Ca ²⁺ -bound)	~340
Excitation (Ca ²⁺ -free)	~380
Emission	~510

Experimental Protocols

I. Preparation of Primary Neuron Cultures

This protocol provides a general method for establishing primary cortical or hippocampal neuron cultures from embryonic rodents.

Materials:

- Embryonic day 18 (E18) mouse or rat pups
- Dissection medium (e.g., ice-cold Hibernate®-A)
- Enzyme dissociation solution (e.g., papain or trypsin)
- Enzyme inhibitor solution
- Neuronal culture medium (e.g., Neurobasal® medium supplemented with B-27® supplement and GlutaMAX™ supplement)
- Poly-D-lysine or poly-L-lysine coated culture plates or coverslips
- Sterile dissection tools

Procedure:

- Coat Culture Vessels: Coat culture plates or coverslips with poly-D-lysine or poly-L-lysine solution overnight at 37°C. The following day, wash the vessels three times with sterile water and allow them to dry completely.

- **Dissection:** Sacrifice pregnant rodents according to institutional guidelines. Dissect embryos and place the brains in ice-cold dissection medium. Under a dissecting microscope, carefully remove the meninges from the cortices or hippocampi.
- **Enzymatic Digestion:** Transfer the dissected tissue to a tube containing the enzyme dissociation solution and incubate at 37°C for the recommended time (typically 15-30 minutes).
- **Trituration:** After incubation, carefully remove the enzyme solution and wash the tissue with neuronal culture medium containing an enzyme inhibitor. Gently triturate the tissue with a fire-polished Pasteur pipette until a single-cell suspension is obtained.
- **Plating:** Determine the cell density using a hemocytometer. Plate the neurons onto the coated culture vessels at the desired density in pre-warmed neuronal culture medium.
- **Culture Maintenance:** Incubate the cultures at 37°C in a humidified atmosphere of 5% CO₂. Change half of the medium every 2-3 days.

II. Fura-PE3 AM Loading

This protocol describes the loading of **Fura-PE3 AM** into primary neurons for calcium imaging.

Materials:

- Primary neuron cultures on glass-bottom dishes or coverslips
- **Fura-PE3 AM**
- Anhydrous DMSO
- Pluronic F-127 (20% solution in DMSO, optional)
- Imaging buffer (e.g., Hanks' Balanced Salt Solution (HBSS) or Tyrode's solution, phenol red-free)[\[4\]](#)

Procedure:

- Prepare **Fura-PE3** AM Stock Solution: For a 4 mM stock solution, dissolve 50 µg of **Fura-PE3** AM in 9 µL of dry DMSO and 1 µL of 20% Pluronic F-127.[3] Vortex vigorously for at least 10 minutes.[3] Store any unused stock solution desiccated and protected from light at -20°C.
- Prepare Loading Solution: Dilute the **Fura-PE3** AM stock solution in imaging buffer to a final working concentration of 1-5 µM. The optimal concentration needs to be determined empirically for your specific neurons.
- Dye Loading: Remove the culture medium from the neurons and wash them once with imaging buffer. Add the **Fura-PE3** AM loading solution to the cells and incubate for 30-60 minutes at 37°C in the dark.[4]
- Wash and De-esterification: After incubation, wash the cells twice with fresh imaging buffer to remove excess dye. Allow the cells to de-esterify the AM ester for at least 30 minutes at room temperature in the dark before imaging. This step is crucial for the dye to become calcium-sensitive.

III. Ratiometric Calcium Imaging

This protocol outlines the procedure for acquiring ratiometric calcium imaging data from **Fura-PE3**-loaded neurons.

Materials:

- **Fura-PE3** loaded primary neuron cultures
- Fluorescence microscope equipped with a light source capable of excitation at 340 nm and 380 nm, an emission filter around 510 nm, and a sensitive camera.
- Agonists or antagonists for stimulating neuronal activity (e.g., glutamate, NMDA, KCl)

Procedure:

- Microscope Setup: Place the dish or coverslip with the loaded neurons on the microscope stage.

- **Image Acquisition:** Acquire fluorescence images by alternating the excitation wavelength between 340 nm and 380 nm. The emission should be collected at approximately 510 nm.[1]
[2]
- **Baseline Recording:** Record a stable baseline fluorescence ratio (F340/F380) for a few minutes before applying any stimulus.
- **Stimulation:** Apply the desired stimulus (e.g., by puff application or perfusion) while continuously acquiring images.
- **Post-Stimulation Recording:** Continue recording after the stimulus has been removed to observe the return to baseline calcium levels.
- **Phototoxicity Prevention:** To minimize phototoxicity, use the lowest possible excitation light intensity and exposure time that still provides a good signal-to-noise ratio.[4] It is also recommended to use a neutral density filter.[4]

IV. Data Analysis

The primary output of a ratiometric calcium imaging experiment is the ratio of the fluorescence intensities at the two excitation wavelengths (Ratio = F340 / F380). This ratio is proportional to the intracellular calcium concentration.

Steps for Data Analysis:

- **Background Subtraction:** For each image, subtract the background fluorescence from a region of interest (ROI) that does not contain any cells.
- **ROI Selection:** Select ROIs corresponding to the cell bodies of individual neurons.
- **Calculate Ratio:** For each ROI at each time point, calculate the ratio of the background-subtracted fluorescence intensity at 340 nm to that at 380 nm.
- **Data Plotting:** Plot the ratio over time to visualize the changes in intracellular calcium concentration.
- **(Optional) Conversion to $[Ca^{2+}]$:** To convert the ratio to an absolute calcium concentration, a calibration is required using the Grynkiewicz equation:[4]

$$[Ca^{2+}] = K_d * [(R - R_{min}) / (R_{max} - R)] * (F_{free_380} / F_{bound_380})$$

Where:

- K_d : The dissociation constant of **Fura-PE3** for Ca^{2+} .
- R : The measured fluorescence ratio (F340/F380).
- R_{min} : The ratio in the absence of calcium (determined using a calcium chelator like EGTA).
- R_{max} : The ratio at saturating calcium concentrations (determined using a calcium ionophore like ionomycin in the presence of high extracellular calcium).
- $F_{free_380} / F_{bound_380}$: The ratio of fluorescence intensities at 380 nm excitation in calcium-free and calcium-saturating conditions, respectively.

Mandatory Visualizations

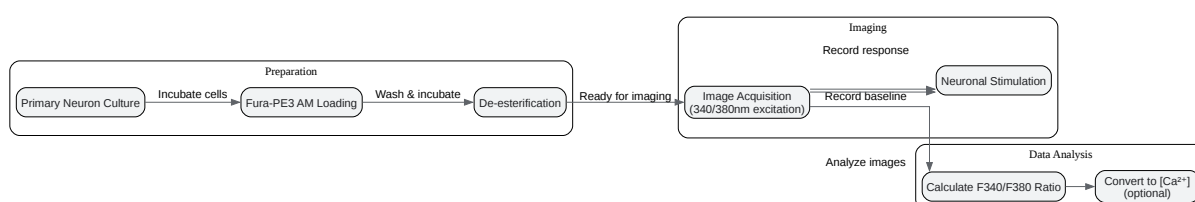

[Click to download full resolution via product page](#)

Caption: Experimental workflow for **Fura-PE3** calcium imaging in primary neurons.

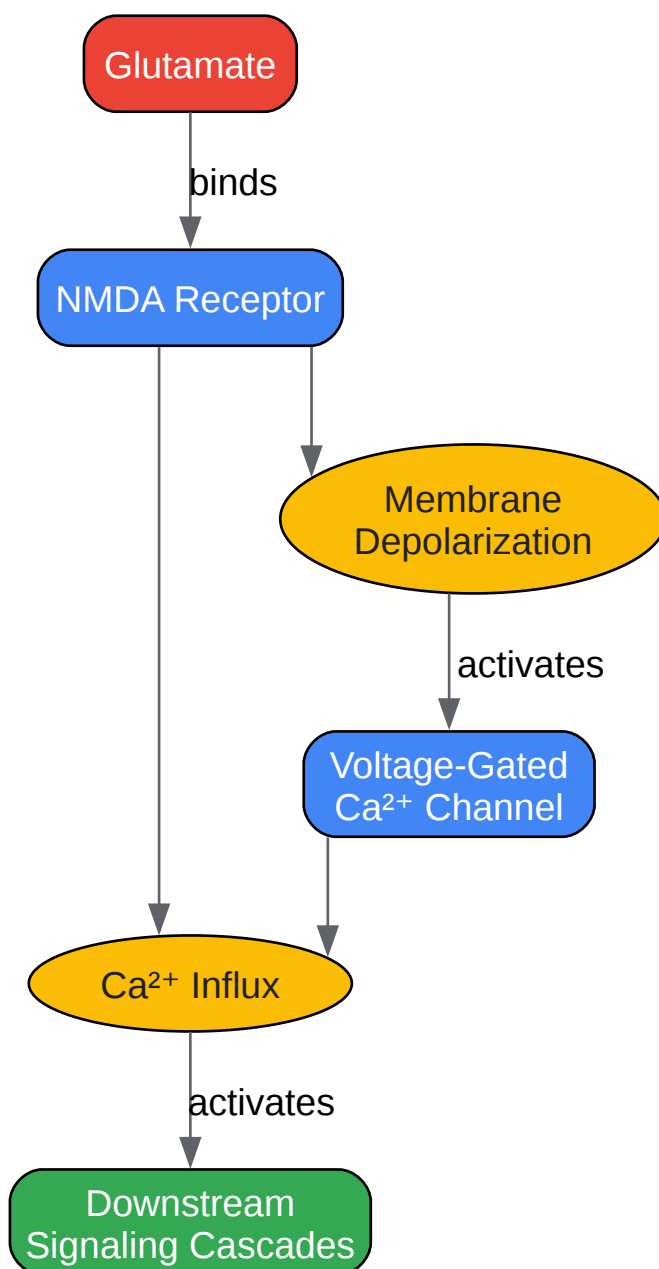

[Click to download full resolution via product page](#)

Caption: Glutamate-NMDA receptor-mediated calcium signaling pathway in neurons.

Troubleshooting

Problem	Possible Cause	Suggested Solution
Low fluorescence signal	- Incomplete de-esterification of Fura-PE3 AM.- Low dye loading concentration.- Photobleaching.	- Increase the de-esterification time.- Optimize the Fura-PE3 AM working concentration.- Reduce excitation light intensity and exposure time. Use a neutral density filter.[4]
High background fluorescence	- Incomplete removal of extracellular dye.- Use of phenol red-containing imaging buffer.	- Ensure thorough washing after dye loading.- Use phenol red-free imaging buffer.[4]
Uneven dye loading	- Cells are not healthy or are detaching.- Inadequate mixing of the loading solution.	- Ensure cells are well-adhered and healthy before loading.- Vortex the Fura-PE3 AM loading solution thoroughly before application.
No response to stimulus	- Cells are not viable.- Stimulus is not effective.- Dye is not properly loaded or de-esterified.	- Check cell viability with a viability stain.- Verify the concentration and activity of your stimulus.- Re-optimize the dye loading and de-esterification protocol.
Ratio changes are noisy or unstable	- Low signal-to-noise ratio.- Phototoxicity causing cell stress.	- Increase the exposure time or binning on the camera.- Reduce the frequency of image acquisition and the intensity of the excitation light. [4]

Need Custom Synthesis?

BenchChem offers custom synthesis for rare earth carbides and specific isotopic labeling.

Email: info@benchchem.com or [Request Quote Online](#).

References

- [1. Calcium imaging of cortical neurons using Fura-2 AM - PubMed \[pubmed.ncbi.nlm.nih.gov\]](#)
- [2. researchgate.net \[researchgate.net\]](#)
- [3. researchgate.net \[researchgate.net\]](#)
- [4. Calcium Imaging of Cortical Neurons using Fura-2 AM - PMC \[pmc.ncbi.nlm.nih.gov\]](#)
- To cite this document: BenchChem. [Application Notes and Protocols for F-PE3 in Primary Neuron Cultures]. BenchChem, [2026]. [Online PDF]. Available at: [\[https://www.benchchem.com/product/b1227955/docs#application-notes-and-protocols-for-f-pe3-in-primary-neuron-cultures\]](https://www.benchchem.com/product/b1227955/docs#application-notes-and-protocols-for-f-pe3-in-primary-neuron-cultures)

Disclaimer & Data Validity:

The information provided in this document is for Research Use Only (RUO) and is strictly not intended for diagnostic or therapeutic procedures. While BenchChem strives to provide accurate protocols, we make no warranties, express or implied, regarding the fitness of this product for every specific experimental setup.

Technical Support: The protocols provided are for reference purposes. Unsure if this reagent suits your experiment?

Need Industrial/Bulk Grade? [Request Custom Synthesis Quote](#)

BenchChem

Our mission is to be the trusted global source of essential and advanced chemicals, empowering scientists and researchers to drive progress in science and industry.

Contact

Address: 3281 E Guasti Rd
Ontario, CA 91761, United States
Phone: (601) 213-4426
Email: info@benchchem.com

Contact our Ph.D. Support Team for a compatibility check