

Validating Mecloxamine's Anticholinergic Effects Through Genetic Approaches: A Comparative Guide

Author: BenchChem Technical Support Team. **Date:** April 2026

Compound of Interest

Compound Name: *Mecloxamine*

CAS No.: *5668-06-4*

Cat. No.: *B1226985*

[Get Quote](#)

For Researchers, Scientists, and Drug Development Professionals

Mecloxamine is an anticholinergic agent recognized for its sedative, hypnotic, antihistaminic, and antiemetic properties. It is often incorporated into combination therapies for headache and migraine management. The primary mechanism of action for **mecloxamine** is understood to be the inhibition of acetylcholine at muscarinic receptors. While direct genetic validation studies specifically for **mecloxamine** are not readily available in published literature, a robust body of research utilizing genetic approaches on its target receptor class—the muscarinic acetylcholine receptors (mAChRs)—provides a strong framework for understanding its effects.

This guide synthesizes findings from genetic studies on muscarinic receptors to infer the validation of **mecloxamine**'s effects. It also presents comparative data for other anticholinergic drugs and outlines the experimental protocols central to these genetic validation approaches.

Genetic Validation via Muscarinic Receptor Knockout Models

The most definitive method to validate the effects of a drug targeting a specific receptor is to observe the physiological and behavioral changes in animal models where that receptor has been genetically removed (knockout). Studies on knockout mice for each of the five muscarinic receptor subtypes (M1-M5) have been instrumental in dissecting the specific roles of each receptor, thereby providing a genetic basis for the effects of non-selective anticholinergic drugs like **mecloxamine**.

Phenotypes of Muscarinic Receptor Knockout Mice Relevant to Mecloxamine's Effects

The sedative and anti-migraine effects of **mecloxamine** can be understood by examining the phenotypes of mice lacking specific muscarinic receptors.

Muscarinic Receptor Subtype	Key Phenotypes in Knockout Mice	Relevance to Mecloxadamine's Effects
M1	Hyperactivity, deficits in cognitive tasks.[1] Seizure resistance to pilocarpine.[2]	M1 receptor antagonism may contribute to cognitive side effects but also has a role in seizure prevention.
M2	Abolished tremor induced by oxotremorine, reduced hypothermia.[2] Key role in movement control and antinociceptive responses.[3]	Blockade of M2 receptors is likely a primary contributor to the sedative and analgesic-sparing effects of mecloxadamine.
M3	Reduced salivation, increased basal pupil diameter.[2]	Antagonism at M3 receptors explains the classic anticholinergic side effects like dry mouth and blurred vision.
M4	Hyperactivity.[1]	M4 receptor blockade may also contribute to locomotor effects.
M5	Limited distinct phenotype in available studies.	The specific contribution of M5 receptor blockade to mecloxadamine's effects is less clear.

Comparative Analysis with Alternative Anticholinergic Agents

While direct head-to-head clinical trials comparing **mecloxadamine** with other anticholinergics are scarce, data from studies on similar drugs used for motion sickness, sedation, and migraine provide a useful comparison.

Efficacy of Anticholinergics in Motion Sickness

A common application for anticholinergic drugs is the prevention of motion sickness, which shares symptomatology with migraine-associated nausea.

Drug	Dosage and Administration	Efficacy Compared to Placebo or Other Agents	Key Side Effects
Transdermal Scopolamine	0.5 mg delivered over 3 days	Superior to placebo and oral meclizine in preventing motion sickness.[4] Motion sickness score reduced by 89%. ^[5]	Dry mouth. ^[4]
Oral Meclizine	Oral tablets	Less effective than transdermal scopolamine. ^[4] Motion sickness score reduced by 59%. ^[5]	Drowsiness.
Diphenhydramine	50 mg IV (in combination with metoclopramide)	Did not show significant improvement in migraine outcomes compared to metoclopramide alone. ^[6]	Drowsiness, dizziness. ^[7]

Sedative Effects of Anticholinergic Medications

The sedative properties of **mecloxamine** are a key aspect of its clinical profile. The sedative load of various anticholinergic drugs is a critical consideration, especially in older adults.

Drug Class	Effect on Sedation
Antihistamines (e.g., Diphenhydramine)	High sedative effect.
Anticholinergics for overactive bladder (e.g., Oxybutynin)	Moderate to high sedative effect.
Tricyclic Antidepressants (e.g., Amitriptyline)	High sedative effect.

Signaling Pathways and Experimental Workflows

The following diagrams illustrate the signaling pathways of muscarinic receptors and a typical experimental workflow for validating an anticholinergic drug using genetic approaches.

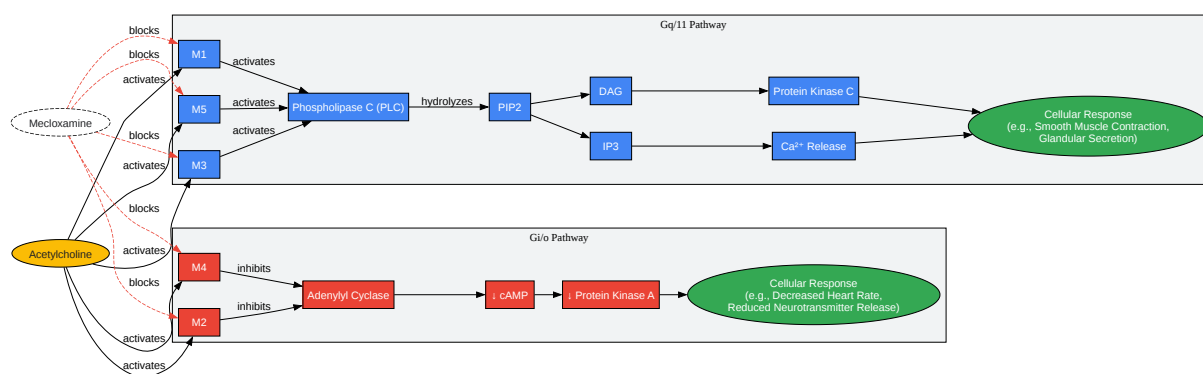

[Click to download full resolution via product page](#)

Figure 1. Muscarinic Acetylcholine Receptor Signaling Pathways.

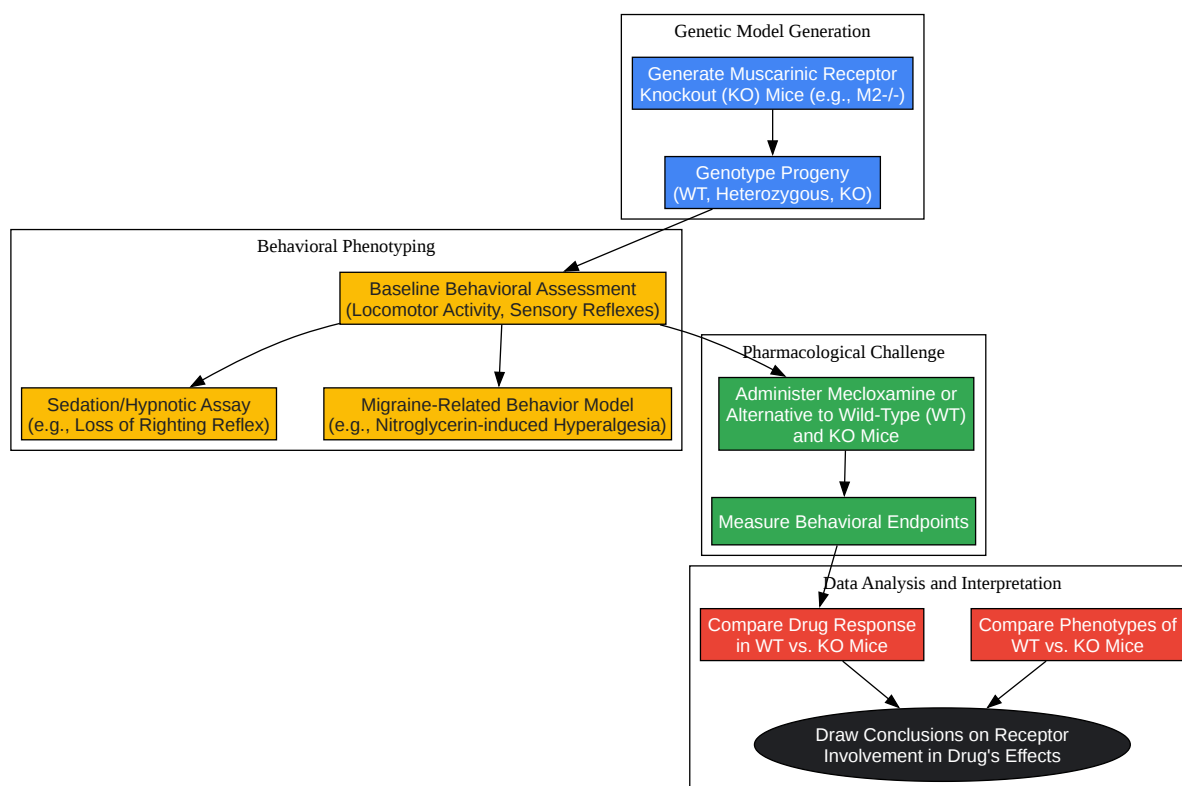

[Click to download full resolution via product page](#)

Figure 2. Experimental Workflow for Genetic Validation.

Experimental Protocols

Validating the effects of an anticholinergic agent like **mecloxamine** using genetic models involves a multi-tiered approach to behavioral phenotyping.

General Health and Neurological Assessment of Knockout Mice

- Objective: To ensure that any observed behavioral differences are not due to general health deficits.
- Procedure:
 - Initial Observation: Mice are observed in their home cages for any abnormalities in posture, grooming, feeding, and social interaction.
 - Physical Measurements: Body weight and temperature are recorded.
 - Sensory and Reflex Testing: A battery of tests is performed, including the visual cliff test (vision), acoustic startle reflex (hearing), and tail-flick test (nociception). Simple reflexes like the righting reflex and whisker twitch are also assessed.
- Reference: A comprehensive approach to behavioral phenotyping is crucial to avoid misinterpretation of data.[\[8\]](#)[\[9\]](#)[\[10\]](#)[\[11\]](#)

Assessment of Sedative/Hypnotic Effects

- Objective: To quantify the sedative effects of the drug and determine the role of specific muscarinic receptors.
- Procedure (Loss of Righting Reflex):
 - Wild-type and muscarinic receptor knockout mice are habituated to the testing room.
 - Mice are administered a hypnotic dose of **mecloxamine** or a comparator drug.
 - Each mouse is placed on its back, and the latency to right itself (return to all four paws) is recorded.

- The duration of the loss of righting reflex is used as a measure of the hypnotic effect.
- Data Analysis: The duration of sleep time is compared between genotypes to determine if the absence of a specific receptor alters the sedative effect of the drug.

Migraine-Related Behavioral Models

- Objective: To model migraine-like pain in mice and assess the efficacy of **mecloxamine**.
- Procedure (Nitroglycerin-Induced Hyperalgesia):
 - A baseline mechanical or thermal sensitivity is established using von Frey filaments or a hot/cold plate test.
 - Mice are administered nitroglycerin to induce a state of hyperalgesia, mimicking migraine pain.
 - **Mecloxamine** or a comparator drug is administered.
 - Mechanical or thermal sensitivity is re-assessed at various time points after drug administration.
- Data Analysis: A significant increase in the pain threshold in drug-treated animals compared to vehicle-treated animals indicates an anti-hyperalgesic effect. Comparing this effect in wild-type versus knockout mice can elucidate the receptor-specific mechanisms.[12][13]

Conclusion

While direct genetic validation of **mecloxamine**'s effects is not documented, the extensive research on muscarinic acetylcholine receptor knockout mice provides compelling indirect evidence. The phenotypes observed in these knockout models, particularly for the M1, M2, and M3 receptors, align with the known sedative, antiemetic, and anticholinergic side effects of **mecloxamine**. The role of the cholinergic system in migraine pathophysiology further supports the therapeutic rationale for its use in headache management.

Comparative data from studies on other anticholinergic drugs like scopolamine and meclizine suggest that while effective, the side effect profiles, particularly sedation and dry mouth, are significant considerations. Future research employing modern genetic tools like CRISPR/Cas9

or siRNA specifically targeting muscarinic receptors in the presence of **mecloxamine** could provide more direct validation of its receptor-specific effects and aid in the development of more targeted therapies with improved side effect profiles. The experimental workflows and protocols outlined in this guide provide a roadmap for such future investigations.

Need Custom Synthesis?

BenchChem offers custom synthesis for rare earth carbides and specific isotopic labeling.

Email: info@benchchem.com or [Request Quote Online](#).

References

- [1. researchgate.net \[researchgate.net\]](#)
- [2. Role of specific muscarinic receptor subtypes in cholinergic parasympathomimetic responses, in vivo phosphoinositide hydrolysis, and pilocarpine-induced seizure activity - PubMed \[pubmed.ncbi.nlm.nih.gov\]](#)
- [3. Pronounced pharmacologic deficits in M2 muscarinic acetylcholine receptor knockout mice - PMC \[pmc.ncbi.nlm.nih.gov\]](#)
- [4. Transdermal scopolamine, oral meclizine, and placebo in motion sickness - PubMed \[pubmed.ncbi.nlm.nih.gov\]](#)
- [5. \[Prevention of motion sickness with a transdermal therapeutic system containing scopolamine. A randomized, comparative double-blind study in the German Federal Navy\] - PubMed \[pubmed.ncbi.nlm.nih.gov\]](#)
- [6. Diphenhydramine as Adjuvant Therapy for Acute Migraine: An Emergency Department-Based Randomized Clinical Trial - PubMed \[pubmed.ncbi.nlm.nih.gov\]](#)
- [7. Diphenhydramine vs Meclizine Comparison - Drugs.com \[drugs.com\]](#)
- [8. Behavioral phenotyping of transgenic and knockout mice: practical concerns and potential pitfalls - PubMed \[pubmed.ncbi.nlm.nih.gov\]](#)
- [9. academic.oup.com \[academic.oup.com\]](#)
- [10. \[PDF\] Behavioral phenotyping of transgenic and knockout mice: practical concerns and potential pitfalls. | Semantic Scholar \[semanticscholar.org\]](#)
- [11. academic.oup.com \[academic.oup.com\]](#)
- [12. mdpi.com \[mdpi.com\]](#)

- 13. Animal models of migraine and experimental techniques used to examine trigeminal sensory processing - PMC [pmc.ncbi.nlm.nih.gov]
- To cite this document: BenchChem. [Validating Mecloxadine's Anticholinergic Effects Through Genetic Approaches: A Comparative Guide]. BenchChem, [2026]. [Online PDF]. Available at: [<https://www.benchchem.com/product/b1226985/docs#validating-mecloxadine-s-anticholinergic-effects-through-genetic-approaches-a-comparative-guide>]

Disclaimer & Data Validity:

The information provided in this document is for Research Use Only (RUO) and is strictly not intended for diagnostic or therapeutic procedures. While BenchChem strives to provide accurate protocols, we make no warranties, express or implied, regarding the fitness of this product for every specific experimental setup.

Technical Support: The protocols provided are for reference purposes. Unsure if this reagent suits your experiment?

Need Industrial/Bulk Grade? [Request Custom Synthesis Quote](#)

BenchChem

Our mission is to be the trusted global source of essential and advanced chemicals, empowering scientists and researchers to drive progress in science and industry.

Contact

Address: 3281 E Guasti Rd

Ontario, CA 91761, United States

Phone: (601) 213-4426

Email: info@benchchem.com

[Contact our Ph.D. Support Team for a compatibility check](#)