

Neuroprotective Effects of Polymethoxyflavones in Disease Models: Application Notes and Protocols

Author: BenchChem Technical Support Team. **Date:** April 2026

Compound of Interest

Compound Name:	4'-Hydroxy-5,6,7,8-tetramethoxyflavone
CAS No.:	36950-98-8
Cat. No.:	B1226744

[Get Quote](#)

For Researchers, Scientists, and Drug Development Professionals

This document provides detailed application notes and protocols on the neuroprotective effects of polymethoxyflavones (PMFs), a class of bioactive compounds found abundantly in citrus peels. The focus is on two prominent PMFs, nobiletin and tangeretin, and their therapeutic potential in preclinical models of neurodegenerative diseases.

Introduction

Polymethoxyflavones (PMFs) are a unique class of flavonoids characterized by multiple methoxy groups attached to the flavone backbone. This structural feature enhances their metabolic stability and ability to cross the blood-brain barrier, making them promising candidates for neurological drug development.[1][2] Extensive research has demonstrated the neuroprotective properties of PMFs, including antioxidant, anti-inflammatory, and anti-apoptotic activities, in various in vitro and in vivo models of neurodegenerative diseases such as Alzheimer's and Parkinson's disease.[2][3][4][5]

Data Presentation: Efficacy of Polymethoxyflavones

The following tables summarize the quantitative data on the neuroprotective effects of nobiletin and tangeretin from preclinical studies.

Table 1: Neuroprotective Effects of Nobiletin in Alzheimer's Disease Models

Model	Treatment	Key Findings	Reference
STZ-induced mouse model of AD	50 mg/kg/day, i.p.	Ameliorated memory deficits; Reduced hippocampal AChE activity by 45.8%; Increased ACh levels by ~80%; Decreased BACE1 activity and A β 42 levels.	[6]
APP-SL 7-5 Tg mice	10 mg/kg/day, i.p. for 4 months	Significantly ameliorated context-dependent fear memory impairment; Reduced A β deposition in the hippocampus; Significantly decreased insoluble A β 1–40 and A β 1–42 levels in the brain.	[3]
3xTg-AD mice	30 mg/kg/day, i.p. for 3 months	Improved short-term and recognition memory; Significantly reduced soluble A β 1-40 levels in the brain.	[3]
iPSC-derived human neurons with PSEN1 mutation	Nobiletin treatment	Significantly upregulated neprilysin mRNA levels; Reduced intraneuronal A β levels; Significantly decreased extracellular A β 1-42 levels.	[7]

Table 2: Neuroprotective Effects of Tangeretin in Parkinson's Disease and Neuroinflammation Models

Model	Treatment	Key Findings	Reference
6-OHDA rat model of PD	20 mg/kg/day, p.o. for 4 days	Markedly reduced the loss of tyrosine hydroxylase positive (TH+) cells in the substantia nigra; Significantly attenuated the decrease in striatal dopamine content.	[8][9]
LPS-stimulated primary rat microglia and BV-2 cells	Dose-dependent	Decreased production of NO, PGE ₂ , TNF- α , IL-1 β , and IL-6; Inhibited iNOS and COX-2 protein expression; Inhibited LPS-induced phosphorylation of ERK, JNK, and p38; Reduced phosphorylation of I κ B- α and IKK- β and nuclear translocation of NF- κ B p65.	[10]
LPS-stimulated microglial cells	Tangeretin treatment	Inhibited production of NO, TNF- α , IL-6, and IL-1 β ; Suppressed mRNA expression of iNOS and cytokines; Inhibited activities and expression of MMP-3 and MMP-8; Enhanced expression of TIMP-2; Suppressed phosphorylation of	[11]

MAPKs and Akt;
Inhibited NF- κ B.

Experimental Protocols

Detailed methodologies for key experiments cited in the literature are provided below.

In Vivo Alzheimer's Disease Model: Streptozotocin (STZ)-Induced Cognitive Impairment

Objective: To induce an animal model of sporadic Alzheimer's disease to evaluate the neuroprotective effects of PMFs.

Materials:

- Male mice
- Streptozotocin (STZ)
- Nobiletin (or other PMF)
- Vehicle (e.g., DMSO)
- Stereotaxic apparatus
- Behavioral testing equipment (e.g., Morris water maze, Y-maze)

Protocol:

- Anesthetize mice and place them in a stereotaxic apparatus.
- Administer a single intracerebroventricular (ICV) injection of STZ (3 mg/kg) to induce cognitive impairment. Control animals receive a vehicle injection.
- Following STZ administration, treat the animals with nobiletin (e.g., 50 mg/kg/day, intraperitoneally) or vehicle for a specified period (e.g., 21 days).

- Conduct behavioral tests such as the Morris water maze or Y-maze to assess learning and memory.
- At the end of the treatment period, sacrifice the animals and collect brain tissue for biochemical and histological analysis (e.g., measurement of A β levels, tau phosphorylation, and inflammatory markers).[6]

In Vivo Parkinson's Disease Model: 6-Hydroxydopamine (6-OHDA)-Induced Dopaminergic Neuron Loss

Objective: To create a unilateral lesion of the nigrostriatal pathway to model Parkinson's disease and assess the neuroprotective effects of PMFs.

Materials:

- Male rats
- 6-Hydroxydopamine (6-OHDA)
- Tangeretin (or other PMF)
- Vehicle
- Stereotaxic apparatus
- Apomorphine or amphetamine for rotational behavior testing

Protocol:

- Pre-treat rats with tangeretin (e.g., 20 mg/kg/day, orally) or vehicle for a specified duration (e.g., 4 days).
- Anesthetize the pre-treated rats and place them in a stereotaxic apparatus.
- Inject 6-OHDA unilaterally into the medial forebrain bundle to induce degeneration of dopaminergic neurons.

- After a recovery period, assess motor asymmetry by measuring rotational behavior induced by apomorphine or amphetamine.
- At the end of the experiment, sacrifice the animals and collect brain tissue (substantia nigra and striatum) for immunohistochemical analysis of tyrosine hydroxylase (TH)-positive neurons and measurement of dopamine levels.[8][9]

In Vitro Neuroinflammation Model: Lipopolysaccharide (LPS)-Stimulated Microglia

Objective: To model neuroinflammation in vitro and evaluate the anti-inflammatory effects of PMFs.

Materials:

- BV-2 microglial cells or primary microglia
- Lipopolysaccharide (LPS)
- Tangeretin (or other PMF)
- Cell culture reagents
- Griess reagent for nitric oxide (NO) assay
- ELISA kits for cytokines (e.g., TNF- α , IL-6)

Protocol:

- Culture BV-2 cells or primary microglia in appropriate media.
- Pre-treat the cells with various concentrations of tangeretin for a specified time (e.g., 1 hour).
- Stimulate the cells with LPS (e.g., 100 ng/mL) to induce an inflammatory response.
- After the incubation period (e.g., 24 hours), collect the cell culture supernatant.
- Measure the levels of NO in the supernatant using the Griess reagent.

- Quantify the concentrations of pro-inflammatory cytokines (TNF- α , IL-6, IL-1 β) in the supernatant using ELISA kits.
- Cell lysates can be prepared for Western blot analysis of inflammatory signaling proteins (e.g., iNOS, COX-2, phosphorylated NF- κ B).[10][11]

Western Blot Analysis of MAPK and NF- κ B Signaling Pathways

Objective: To determine the effect of PMFs on the activation of key signaling pathways involved in neuroinflammation and cell survival.

Materials:

- Cell lysates from treated and control cells
- Protein assay kit (e.g., BCA)
- SDS-PAGE gels
- PVDF membranes
- Primary antibodies (e.g., anti-p-ERK, anti-ERK, anti-p-NF- κ B p65, anti-NF- κ B p65, anti- β -actin)
- HRP-conjugated secondary antibodies
- Chemiluminescent substrate

Protocol:

- Prepare cell lysates from cells treated with PMFs and/or a stimulus (e.g., LPS).
- Determine the protein concentration of each lysate using a BCA assay.
- Separate equal amounts of protein (e.g., 20-30 μ g) on an SDS-PAGE gel.
- Transfer the separated proteins to a PVDF membrane.

- Block the membrane with a blocking buffer (e.g., 5% non-fat milk in TBST) for 1 hour at room temperature.
- Incubate the membrane with the primary antibody of interest (e.g., anti-p-ERK) overnight at 4°C.
- Wash the membrane and incubate with the appropriate HRP-conjugated secondary antibody for 1 hour at room temperature.
- Detect the protein bands using a chemiluminescent substrate and an imaging system.
- Normalize the levels of phosphorylated proteins to their total protein levels and to a loading control (e.g., β -actin).[\[12\]](#)[\[13\]](#)[\[14\]](#)[\[15\]](#)[\[16\]](#)

Visualization of Signaling Pathways

The following diagrams illustrate the key signaling pathways modulated by polymethoxyflavones in the context of neuroprotection.

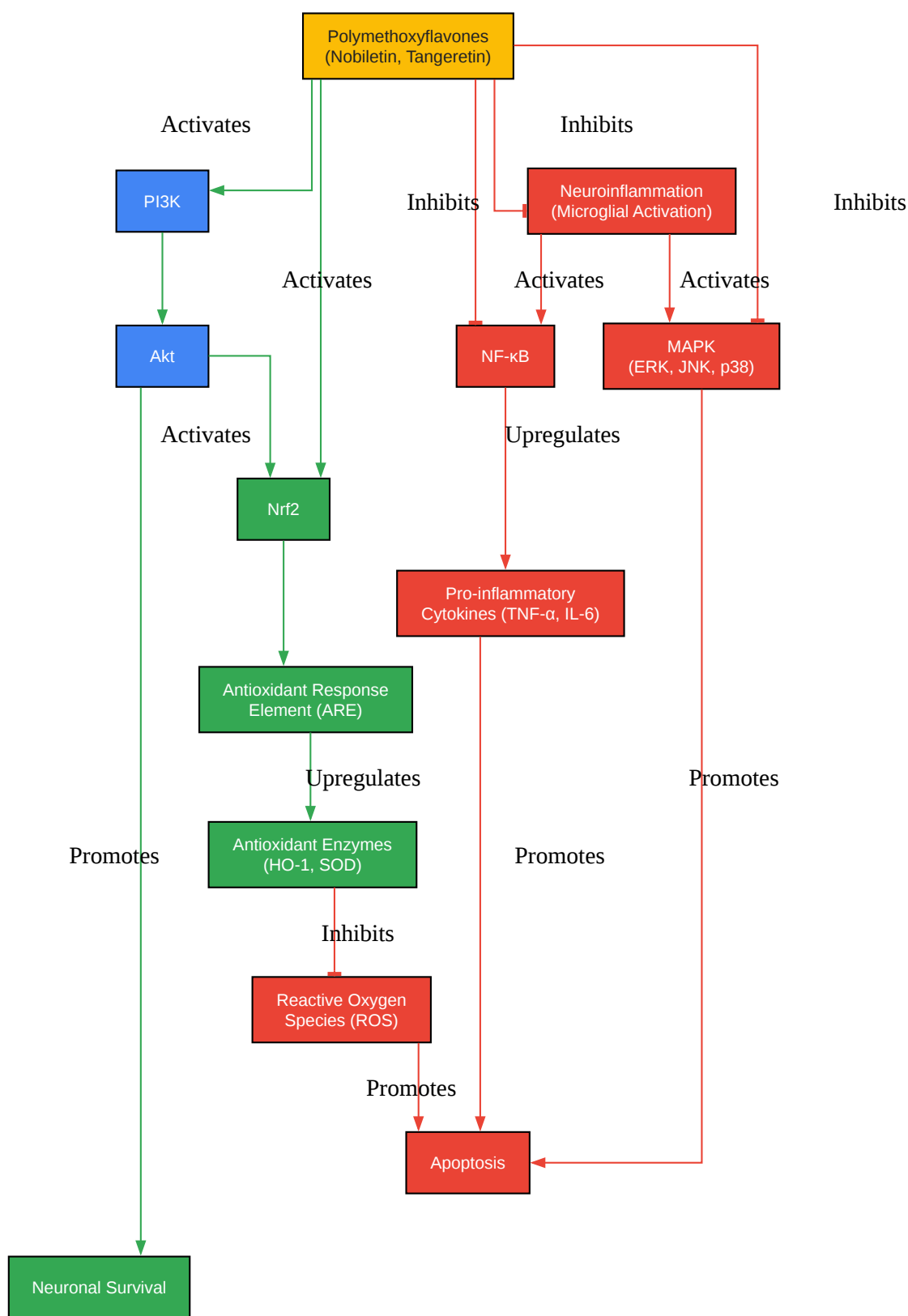

[Click to download full resolution via product page](#)

Caption: Key signaling pathways modulated by PMFs for neuroprotection.

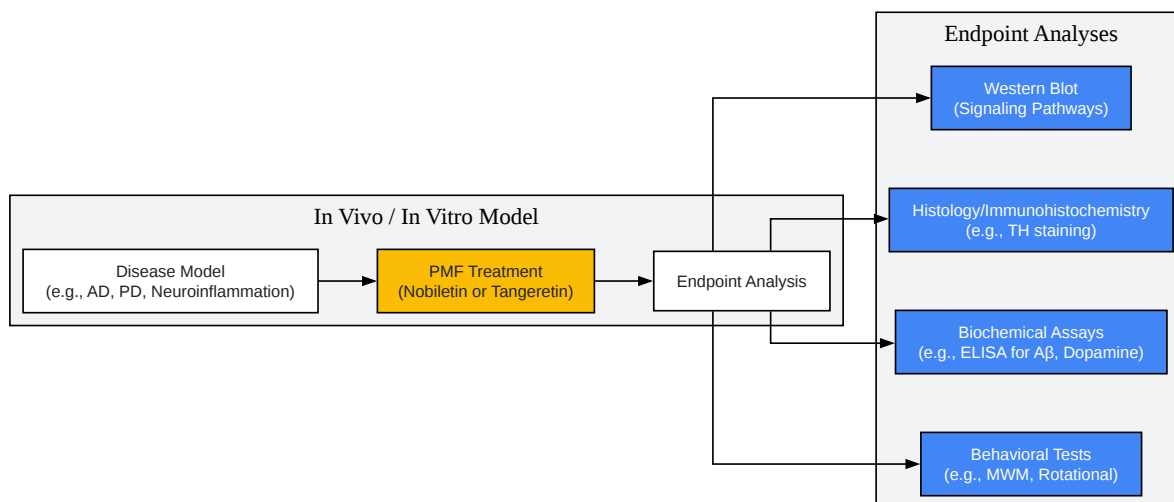

[Click to download full resolution via product page](#)

Caption: General experimental workflow for studying PMF neuroprotection.

Conclusion

Polymethoxyflavones, particularly nobiletin and tangeretin, demonstrate significant neuroprotective potential in preclinical models of neurodegenerative diseases. Their ability to modulate multiple signaling pathways involved in oxidative stress, neuroinflammation, and apoptosis underscores their promise as therapeutic agents. The provided protocols and data serve as a valuable resource for researchers and drug development professionals interested in exploring the therapeutic applications of PMFs for neurological disorders. Further research, including clinical trials, is warranted to translate these promising preclinical findings into effective therapies for patients.^[17]

Need Custom Synthesis?

BenchChem offers custom synthesis for rare earth carbides and specific isotopic labeling.

Email: info@benchchem.com or [Request Quote Online](#).

References

- [1. jddtonline.info \[jddtonline.info\]](http://jddtonline.info)
- [2. researchers.mq.edu.au \[researchers.mq.edu.au\]](http://researchers.mq.edu.au)
- [3. mdpi.com \[mdpi.com\]](http://mdpi.com)
- [4. Potential role of nobiletin in Alzheimer's disease | Journal of Food Bioactives \[isnff-jfb.com\]](http://isnff-jfb.com)
- [5. The Neuroprotective Role of Tangeritin - PubMed \[pubmed.ncbi.nlm.nih.gov\]](http://pubmed.ncbi.nlm.nih.gov)
- [6. The citrus flavonoid "Nobiletin" impedes STZ-induced Alzheimer's disease in a mouse model through regulating autophagy mastered by SIRT1/FoxO3a mechanism - PMC \[pmc.ncbi.nlm.nih.gov\]](http://pmc.ncbi.nlm.nih.gov)
- [7. Nobiletin Reduces Intracellular and Extracellular \$\beta\$ -Amyloid in iPS Cell-Derived Alzheimer's Disease Model Neurons - PubMed \[pubmed.ncbi.nlm.nih.gov\]](http://pubmed.ncbi.nlm.nih.gov)
- [8. Tissue distribution and neuroprotective effects of citrus flavonoid tangeretin in a rat model of Parkinson's disease - PubMed \[pubmed.ncbi.nlm.nih.gov\]](http://pubmed.ncbi.nlm.nih.gov)
- [9. researchgate.net \[researchgate.net\]](http://researchgate.net)
- [10. Tangeretin exerts anti-neuroinflammatory effects via NF- \$\kappa\$ B modulation in lipopolysaccharide-stimulated microglial cells - PubMed \[pubmed.ncbi.nlm.nih.gov\]](http://pubmed.ncbi.nlm.nih.gov)
- [11. Anti-Inflammatory and Antioxidant Mechanism of Tangeretin in Activated Microglia - PubMed \[pubmed.ncbi.nlm.nih.gov\]](http://pubmed.ncbi.nlm.nih.gov)
- [12. Frontiers | Nobiletin Inhibits Cell Viability via the SRC/AKT/STAT3/YY1AP1 Pathway in Human Renal Carcinoma Cells \[frontiersin.org\]](http://frontiersin.org)
- [13. mdpi.com \[mdpi.com\]](http://mdpi.com)
- [14. researchgate.net \[researchgate.net\]](http://researchgate.net)
- [15. Nobiletin induces inhibitions of Ras activity and mitogen-activated protein kinase kinase/extracellular signal-regulated kinase signaling to suppress cell proliferation in C6 rat glioma cells - PubMed \[pubmed.ncbi.nlm.nih.gov\]](http://pubmed.ncbi.nlm.nih.gov)

- 16. Nobiletin can play a role in improving inflammation by inhibiting the NF-kB and MAPK pathways in muscle cells - PubMed [pubmed.ncbi.nlm.nih.gov]
- 17. Further evaluation fo the neuroprotective effects of citrus flavenoid tangeretin in a pre-clinical model of PD | Parkinson's Disease [michaeljfox.org]
- To cite this document: BenchChem. [Neuroprotective Effects of Polymethoxyflavones in Disease Models: Application Notes and Protocols]. BenchChem, [2026]. [Online PDF]. Available at: [https://www.benchchem.com/product/b1226744/docs#neuroprotective-effects-of-polymethoxyflavones-in-disease-models-application-notes-and-protocols]

Disclaimer & Data Validity:

The information provided in this document is for Research Use Only (RUO) and is strictly not intended for diagnostic or therapeutic procedures. While BenchChem strives to provide accurate protocols, we make no warranties, express or implied, regarding the fitness of this product for every specific experimental setup.

Technical Support: The protocols provided are for reference purposes. Unsure if this reagent suits your experiment?

Need Industrial/Bulk Grade? [Request Custom Synthesis Quote](#)

BenchChem

Our mission is to be the trusted global source of essential and advanced chemicals, empowering scientists and researchers to drive progress in science and industry.

Contact

Address: 3281 E Guasti Rd
Ontario, CA 91761, United States
Phone: (601) 213-4426
Email: info@benchchem.com

[Contact our Ph.D. Support Team for a compatibility check](#)

