

# Technical Support Center: Coelichelin and its Derivatives - Stability in Solution

**Author:** BenchChem Technical Support Team. **Date:** December 2025

## Compound of Interest

Compound Name: *Coelichelin*

Cat. No.: *B1225944*

[Get Quote](#)

For Researchers, Scientists, and Drug Development Professionals

This technical support center provides essential guidance on the stability of **coelichelin** and its derivatives in solution. Below you will find frequently asked questions (FAQs) and troubleshooting guides to address common challenges encountered during experimental work.

## Frequently Asked Questions (FAQs)

Q1: What are the primary factors that influence the stability of **coelichelin** and its derivatives in solution?

A1: The stability of **coelichelin**, a tetrapeptide hydroxamate siderophore, is influenced by several factors inherent to its structure and the experimental conditions. Key factors include:

- **pH:** The pH of the solution is a critical factor. Peptide bonds are susceptible to hydrolysis under both acidic and basic conditions. For many peptides, a slightly acidic pH of 4-6 is often optimal for minimizing hydrolysis.[1]
- **Temperature:** Higher temperatures accelerate the rate of chemical degradation, including hydrolysis, deamidation, and oxidation.[1] For long-term storage, freezing at -20°C or -80°C is recommended.[1]
- **Oxidation:** The presence of oxidizing agents or dissolved oxygen can lead to the degradation of certain amino acid residues. While **coelichelin**'s exact sequence may not contain highly

susceptible residues like methionine or cysteine, it's a good practice to use deoxygenated buffers for sensitive experiments.[2]

- Enzymatic Degradation: If working with biological samples, proteases can enzymatically cleave the peptide bonds of **coelichelin**.
- Light Exposure: Some amino acid residues can be sensitive to light, so it is advisable to store solutions in amber vials or otherwise protected from light.[1]

Q2: What are the signs of **coelichelin** degradation in my solution?

A2: Degradation of **coelichelin** can manifest in several ways:

- Loss of Biological Activity: A decrease in the expected biological effect, such as reduced iron chelation capacity or diminished activity in cell-based assays.
- Changes in Chromatographic Profile: When analyzed by High-Performance Liquid Chromatography (HPLC), the appearance of new peaks or a decrease in the area of the main **coelichelin** peak is a strong indicator of degradation.
- Precipitation or Aggregation: While more of a physical instability, chemical degradation can sometimes lead to conformational changes that promote aggregation and precipitation out of solution.[3]

Q3: What are the recommended storage conditions for **coelichelin** solutions?

A3: To ensure the longevity of your **coelichelin** solutions, follow these storage guidelines:

- Short-term Storage (days to weeks): Store at 2-8°C in a tightly sealed container.[1]
- Long-term Storage (weeks to months): For optimal stability, aliquot the solution into single-use volumes to avoid repeated freeze-thaw cycles and store at -20°C or -80°C.[1][4]
- Solvent Choice: Use high-purity, sterile solvents and buffers. A slightly acidic buffer (pH 4-6) is generally a good starting point for stability.[1]

## Troubleshooting Guides

## Issue 1: Rapid Loss of Activity in Aqueous Buffer

Potential Cause	Troubleshooting Steps	Expected Outcome
Hydrolysis of Peptide Bonds	<ol style="list-style-type: none"><li>Optimize pH: Prepare the coelichelin solution in a buffer with a slightly acidic pH (e.g., pH 5.0 acetate buffer).</li><li>Lower Temperature: Conduct experiments at the lowest feasible temperature. If possible, keep samples on ice.</li></ol>	Increased half-life of the active compound in solution.
Oxidation	<ol style="list-style-type: none"><li>Deoxygenate Buffers: Sparge buffers with an inert gas (e.g., argon or nitrogen) before use.</li><li>Add Antioxidants: If compatible with your assay, consider adding antioxidants like DTT or TCEP, particularly if derivatives contain susceptible residues.<sup>[2]</sup></li></ol>	Reduced formation of oxidation-related degradation products.
Adsorption to Surfaces	<ol style="list-style-type: none"><li>Use Low-Binding Tubes: Utilize polypropylene or silanized glass vials.</li><li>Include a Carrier Protein: For very dilute solutions, adding a carrier protein like BSA (if compatible with the experiment) can prevent adsorption.</li></ol>	Consistent and reproducible concentrations in your assays.

## Issue 2: Appearance of Multiple Peaks in HPLC Analysis

Potential Cause	Troubleshooting Steps	Expected Outcome
Forced Degradation During Sample Preparation	1. Control Temperature: Keep samples cool during preparation and analysis.2. Check pH of Mobile Phase: Ensure the pH of the mobile phase is not contributing to on-column degradation.	A cleaner chromatogram with a predominant peak for the intact coelichelin.
Presence of Degradation Products	1. Perform a Forced Degradation Study: Intentionally degrade a small sample of coelichelin (e.g., with acid, base, or peroxide) to identify the retention times of potential degradation products. [5]	Confirmation of whether the additional peaks correspond to known degradation products.
Impure Starting Material	1. Verify Purity of New Batch: Always check the purity of a new batch of coelichelin or its derivatives upon receipt.2. Re-purify if Necessary: If purity is a concern, consider re-purification by preparative HPLC.	A single, sharp peak corresponding to the pure compound.

## Data Presentation: Stability of a Representative Peptide-Hydroxamate Compound

The following table provides illustrative data on the stability of a peptide-hydroxamate compound under various conditions, as determined by HPLC analysis. This data is intended to serve as a general guide for understanding the stability profile of **coelichelin** and its derivatives.

Condition	Time (hours)	% Remaining (pH 4.0)	% Remaining (pH 7.0)	% Remaining (pH 9.0)
4°C	0	100	100	100
	24	98	95	90
	48	96	90	82
	72	95	86	75
25°C	0	100	100	100
	24	92	85	70
	48	85	72	55
	72	78	60	40
37°C	0	100	100	100
	24	80	65	45
	48	65	45	25
	72	50	30	10

## Experimental Protocols

### Protocol 1: General HPLC-Based Stability Assay

This protocol outlines a general method for assessing the stability of **coelichelin** in a given solution over time.

- Preparation of Stock Solution:
  - Accurately weigh a small amount of lyophilized **coelichelin**.
  - Dissolve in an appropriate solvent (e.g., sterile water or a buffer of choice) to a known concentration.
- Incubation:

- Aliquot the stock solution into separate vials for each time point and condition to be tested (e.g., different pH values and temperatures).
- Store the vials under the specified conditions.
- Sample Analysis by HPLC:
  - At each designated time point, remove a vial from its storage condition.
  - If frozen, allow the sample to thaw completely at room temperature.
  - Inject a fixed volume of the sample onto a suitable HPLC column (e.g., a C18 column).
  - Use a mobile phase gradient appropriate for separating **coelichelin** from its potential degradation products (e.g., a water/acetonitrile gradient with 0.1% TFA).
  - Detect the eluting compounds using a UV detector at an appropriate wavelength (e.g., 214 nm for the peptide backbone).
- Data Analysis:
  - Integrate the peak area of the intact **coelichelin** at each time point.
  - Calculate the percentage of remaining **coelichelin** relative to the initial time point (t=0).
  - Plot the percentage of remaining **coelichelin** versus time for each condition.

## Visualizations

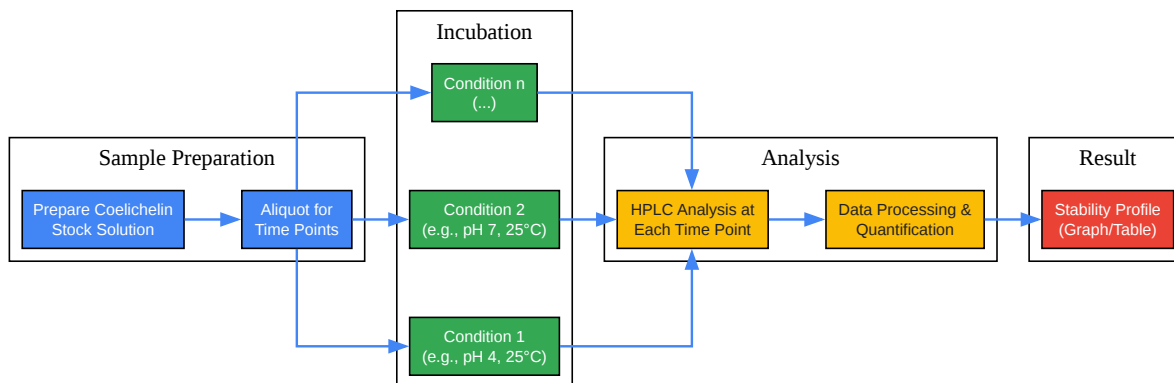

[Click to download full resolution via product page](#)

Caption: Workflow for assessing the stability of **coelichelin**.

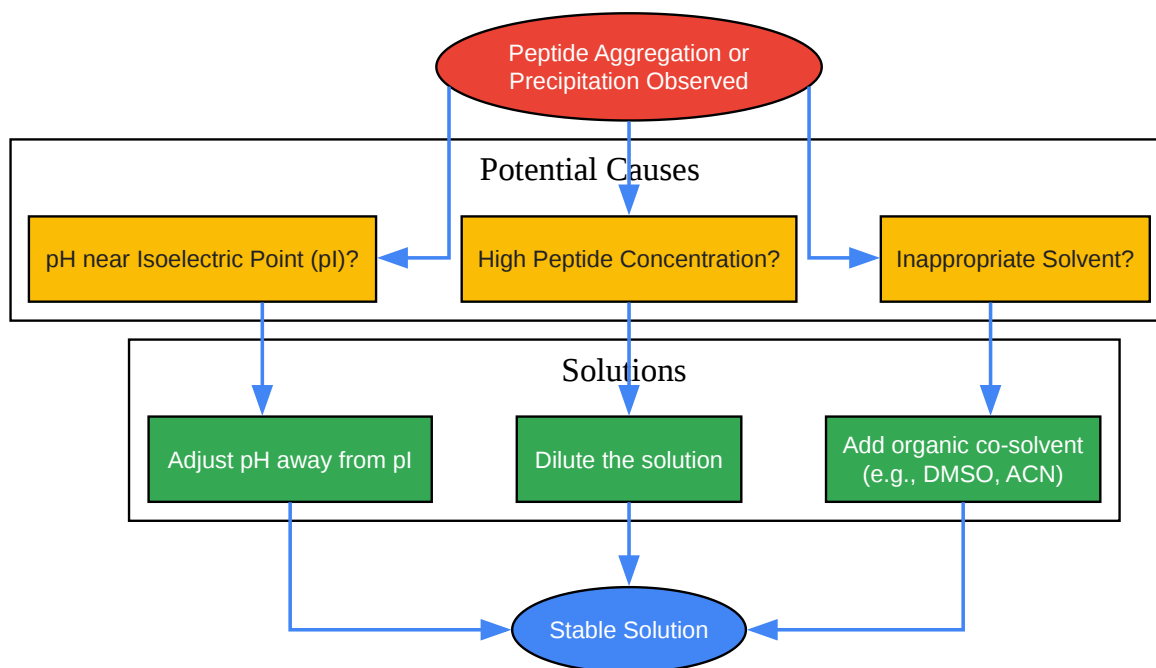

[Click to download full resolution via product page](#)

Caption: Troubleshooting logic for peptide aggregation issues.

### Need Custom Synthesis?

BenchChem offers custom synthesis for rare earth carbides and specific isotopic labeling.

Email: [info@benchchem.com](mailto:info@benchchem.com) or [Request Quote Online](#).

## References

- 1. benchchem.com [benchchem.com]
- 2. proimmune.com [proimmune.com]
- 3. benchchem.com [benchchem.com]
- 4. sigmaaldrich.com [sigmaaldrich.com]
- 5. Forced Degradation Studies - STEMart [ste-mart.com]
- To cite this document: BenchChem. [Technical Support Center: Coelichelin and its Derivatives - Stability in Solution]. BenchChem, [2025]. [Online PDF]. Available at: [https://www.benchchem.com/product/b1225944#stability-issues-of-coelichelin-and-its-derivatives-in-solution]

---

### Disclaimer & Data Validity:

The information provided in this document is for Research Use Only (RUO) and is strictly not intended for diagnostic or therapeutic procedures. While BenchChem strives to provide accurate protocols, we make no warranties, express or implied, regarding the fitness of this product for every specific experimental setup.

**Technical Support:** The protocols provided are for reference purposes. Unsure if this reagent suits your experiment? [[Contact our Ph.D. Support Team for a compatibility check](#)]

**Need Industrial/Bulk Grade?** [Request Custom Synthesis Quote](#)



# BenchChem

Our mission is to be the trusted global source of essential and advanced chemicals, empowering scientists and researchers to drive progress in science and industry.

## Contact

Address: 3281 E Guasti Rd

Ontario, CA 91761, United States

Phone: (601) 213-4426

Email: [info@benchchem.com](mailto:info@benchchem.com)