

Technical Guide: Minimizing Background Fluorescence in 4-Aminostilbene Imaging[1]

Author: BenchChem Technical Support Team. **Date:** May 2026

Compound of Interest

Compound Name: 4-Aminostilbene

CAS No.: 834-24-2

Cat. No.: B1224771

[Get Quote](#)

Technical Brief: The "Blue/UV" Conundrum

4-Aminostilbene (4-AS) and its derivatives typically present a Stokes shift involving excitation in the UV/Violet region (~330–370 nm) and emission in the Blue/Cyan region (~400–470 nm). This places the fluorophore in the most congested spectral window of biological imaging.

The Core Challenge: The excitation wavelength of 4-AS directly overlaps with the absorption spectra of endogenous tissue fluorophores, specifically:

- NADH/NAD(P)H: Metabolic cofactors (Excitation ~340 nm / Emission ~460 nm).[1]
- Collagen & Elastin: Structural proteins (Excitation ~300-370 nm / Emission ~400-450 nm).[1]
- Fixative-Induced Fluorescence: Aldehyde cross-linking generates Schiff bases that fluoresce broadly in the blue-green spectrum.[1]

To visualize 4-AS effectively, we cannot simply "turn up the gain." We must systematically dismantle the sources of background noise using a combination of optical physics and chemical quenching.

Phase 1: Optical Isolation Strategies[1]

Before altering sample chemistry, optimize the optical path. Standard DAPI filter sets are often too broad for high-fidelity 4-AS imaging in tissue.[1]

Narrow-Band Excitation

Standard UV filters often have wide excitation windows (e.g., 330–385 nm).[1] This excites a maximal amount of tissue autofluorescence.[1]

- Recommendation: Switch to a narrow bandpass excitation filter centered strictly on the 4-AS peak (e.g., 365/10 nm).
- Why: Narrowing the excitation energy reduces the total photon flux hitting off-target endogenous fluorophores like flavins, which have broader absorption shoulders.

Spectral Unmixing (The "Lambda Stack")

If you have access to a spectral confocal microscope (e.g., Zeiss LSM, Leica SP8/Stellaris), this is the gold standard method.

Protocol: Linear Unmixing for 4-AS

- Reference Control (Negative): Image an unstained tissue sample using 4-AS settings to generate the "Autofluorescence Spectrum."
- Reference Control (Positive): Image 4-AS in solution or on non-autofluorescent beads to generate the "Pure Dye Spectrum."
- Acquisition: Acquire the experimental image in "Lambda Mode" (collecting emission in 10nm bins from 400 nm to 600 nm).
- Unmixing: Use the software's linear unmixing algorithm to mathematically separate the pixel contributions of the Autofluorescence Spectrum from the Pure Dye Spectrum.

Phase 2: Chemical Quenching & Sample Prep[1]

If optical isolation is insufficient, or if you are using widefield microscopy, chemical intervention is required.^[1]

The Fixation Factor

Issue: Glutaraldehyde is a potent fixative but creates extensive resonant double bonds (Schiff bases), leading to intense background fluorescence in the 4-AS emission channel. Solution:

- Use 4% Paraformaldehyde (PFA) instead of Glutaraldehyde whenever possible.^[1]
- If Glutaraldehyde is required for ultrastructure, you must perform a reduction step (see Protocol A below).^[1]

Protocol A: Sodium Borohydride (NaBH₄) Reduction

Best for: Quenching fixative-induced background (Schiff bases).^[1]

- Preparation: Prepare a fresh solution of 1 mg/mL (0.1%) Sodium Borohydride in PBS or TBS.
 - Warning: NaBH₄ releases hydrogen gas rapidly.^[1] Prepare immediately before use in an open container (do not cap tightly).
- Incubation: Incubate fixed, permeabilized samples in the NaBH₄ solution for 10 minutes at room temperature.
 - Note: You should see small bubbles forming; this indicates the reduction reaction is active.
- Wash: Wash samples 3 x 5 minutes with PBS to remove residual borohydride.
- Proceed: Continue with blocking and staining.^[1]

Protocol B: Sudan Black B (SBB) Treatment

Best for: Quenching lipofuscin and lipid-rich tissue autofluorescence. Constraint:^[1] SBB is highly effective but fluoresces in the Red/Far-Red channels.^{[1][2]} Only use this if 4-AS (Blue) is your primary target or if you are not imaging in the 600nm+ range.

- Staining: Perform your 4-AS staining and any immunolabeling first.^[1]

- Preparation: Dissolve 0.1% Sudan Black B in 70% Ethanol. Stir for 2 hours, then filter through a 0.2 μm syringe filter to remove precipitates.
- Incubation: Immerse the slide/sample in the SBB solution for 10–15 minutes at room temperature.
- Wash: Wash quickly with 70% Ethanol (3 x 1 minute) to remove excess dye, followed by extensive rehydration in PBS.
- Mount: Mount in a non-fluorescent medium (e.g., glycerol-based without DAPI).

Visualizing the Workflow

Diagram 1: The Spectral Conflict & Resolution

This diagram illustrates the overlapping noise sources and the logical filtration steps.

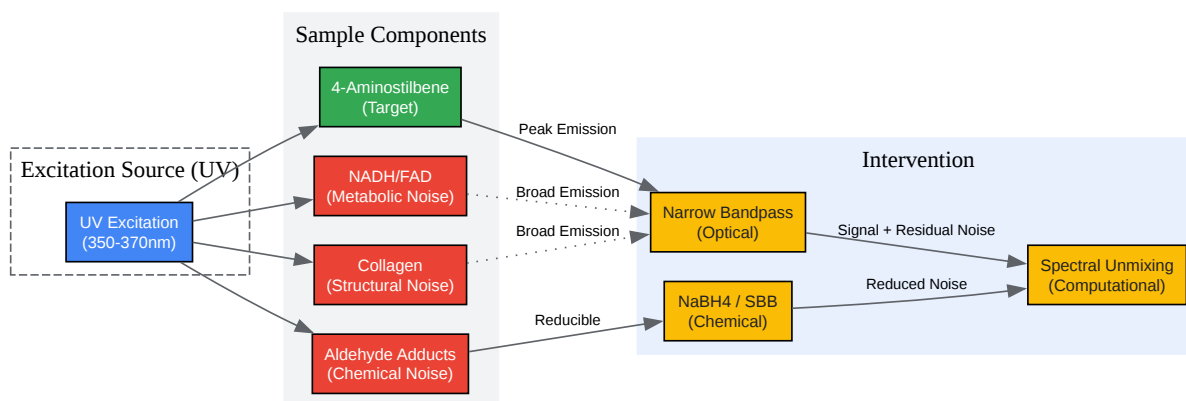

[Click to download full resolution via product page](#)

Caption: Figure 1. Signal flow showing the interaction between UV excitation, endogenous noise sources, and the three-tiered intervention strategy (Optical, Computational, Chemical).

Troubleshooting & FAQs

Q1: I see bright punctate spots outside my target area. Is this autofluorescence?

Diagnosis: This is likely Non-Specific Binding (NSB), not autofluorescence. **4-Aminostilbene** is a hydrophobic molecule (stilbene core).[1] It tends to aggregate in lipid droplets or stick to hydrophobic domains on the slide surface. Corrective Action:

- Increase Surfactant: Add 0.05% - 0.1% Tween-20 to your wash buffers.[1][3]
- Blocking: Ensure you block with 1-3% BSA (Bovine Serum Albumin) for at least 30 minutes prior to staining.[1] The albumin binds to sticky hydrophobic sites, preventing the dye from adhering there.

Q2: My background is high, but I cannot use Sudan Black B because I have a Red channel marker.

Diagnosis: SBB fluorescence in the red channel (600nm+) will mask your secondary marker. Corrective Action:

- Use Copper Sulfate (CuSO₄): Incubate samples in 10 mM CuSO₄ in 50 mM ammonium acetate buffer (pH 5).[1]0 for 10-20 minutes. This quenches lipofuscin with less red-channel interference than SBB, though it is slightly less potent.[1]
- Photobleaching: "Pre-burn" the autofluorescence.[1] Expose the sample to high-intensity UV light (using the microscope objective) for 10–20 minutes before adding the 4-AS stain. Autofluorescence often photobleaches faster than stable synthetic dyes (though you must stain after bleaching).[1]

Q3: Can I use 4-AS in live-cell imaging?

Diagnosis: Yes, but phenol red in culture media is a major source of background in the blue/UV channel. Corrective Action:

- Switch to FluoroBrite™ DMEM or a clear, phenol-red-free imaging buffer (e.g., HBSS with HEPES) immediately prior to imaging.[1]

Comparison of Quenching Methods

Method	Target Noise Source	Pros	Cons
Sodium Borohydride (NaBH ₄)	Aldehyde Fixatives (Schiff Bases)	Chemically reduces the noise source; restores antigenicity. [1]	Generates gas bubbles (can detach delicate sections); short shelf-life.[1]
Sudan Black B (SBB)	Lipofuscin / Lipids	Extremely effective; high contrast.[1]	Fluoresces in Red/Far-Red; messy to handle (ethanol based).[1]
Copper Sulfate (CuSO ₄)	Lipofuscin	Compatible with more fluorophores than SBB.[1]	Less potent quenching than SBB; pH sensitive.[1]
Spectral Unmixing	All overlapping spectra	Non-destructive; preserves original data.[1]	Requires advanced hardware (Spectral Confocal); requires reference controls.[1]

References

- Baschong, W., et al. (2001).[1] "Control of autofluorescence of archival formaldehyde-fixed, paraffin-embedded tissue in confocal laser scanning microscopy." Journal of Histochemistry & Cytochemistry.
- Schnell, S. A., et al. (1999).[1] "Reduction of lipofuscin-like autofluorescence in fluorescently labeled tissue." Journal of Histochemistry & Cytochemistry. (Establishes Sudan Black B protocol).
- McRae, T. D., et al. (2019).[1][4] "Robust blind spectral unmixing for fluorescence microscopy using unsupervised learning." PLOS ONE.
- Biotium Tech Tips. (2021). "Battling Tissue Autofluorescence." (Overview of quenching mechanisms including SBB and TrueBlack).

- Yang, J., et al. (2002).[1][5] "Fluorescence Enhancement of trans-4-Aminostilbene by N-Phenyl Substitutions." Journal of the American Chemical Society.[5] (Spectral properties of 4-AS).

Need Custom Synthesis?

BenchChem offers custom synthesis for rare earth carbides and specific isotopic labeling.

Email: info@benchchem.com or [Request Quote Online](#).

Sources

- 1. 4,4'-Diaminostilbene | C14H14N2 | CID 5284646 - PubChem [pubchem.ncbi.nlm.nih.gov]
- 2. biotium.com [biotium.com]
- 3. Reducing Non-Specific Binding [reichertspr.com]
- 4. Robust blind spectral unmixing for fluorescence microscopy using unsupervised learning | PLOS One [journals.plos.org]
- 5. scholars.lib.ntu.edu.tw [scholars.lib.ntu.edu.tw]
- To cite this document: BenchChem. [Technical Guide: Minimizing Background Fluorescence in 4-Aminostilbene Imaging[1]]. BenchChem, [2026]. [Online PDF]. Available at: [<https://www.benchchem.com/product/b1224771/docs#technical-guide-minimizing-background-fluorescence-in-4-aminostilbene-imaging-1>]

Disclaimer & Data Validity:

The information provided in this document is for Research Use Only (RUO) and is strictly not intended for diagnostic or therapeutic procedures. While BenchChem strives to provide accurate protocols, we make no warranties, express or implied, regarding the fitness of this product for every specific experimental setup.

Technical Support: The protocols provided are for reference purposes. Unsure if this reagent suits your experiment?

Need Industrial/Bulk Grade? [Request Custom Synthesis Quote](#)

BenchChem

Our mission is to be the trusted global source of essential and advanced chemicals, empowering scientists and researchers to drive progress in science and industry.

Contact

Address: 3281 E Guasti Rd
Ontario, CA 91761, United States
Phone: (601) 213-4426
Email: info@benchchem.com

[Contact our Ph.D. Support Team for a compatibility check](#)