

Optimizing culture conditions for plant cell suspension to produce (+)-Scoulerine.

Author: BenchChem Technical Support Team. **Date:** December 2025

Compound of Interest

Compound Name: (+)-Scoulerine

Cat. No.: B1224586

[Get Quote](#)

Technical Support Center: (+)-Scoulerine Production

This technical support center provides researchers, scientists, and drug development professionals with comprehensive troubleshooting guides and frequently asked questions (FAQs) for optimizing plant cell suspension cultures for the production of **(+)-Scoulerine**.

Frequently Asked Questions (FAQs)

Q1: What is **(+)-Scoulerine** and why is it a target for production in plant cell cultures?

A1: **(+)-Scoulerine**, also known as (S)-Scoulerine, is a protoberberine benzyloisoquinoline alkaloid (BIA). It serves as a critical branch-point intermediate in the biosynthesis of a wide range of pharmacologically important alkaloids, including berberine, sanguinarine, and noscapine.[1] Producing it in plant cell cultures offers a controlled, sustainable, and scalable alternative to extraction from whole plants, which can be limited by geographical, environmental, and seasonal factors.[2][3]

Q2: What is the general workflow for producing **(+)-Scoulerine** in a plant cell suspension culture?

A2: The process involves several key stages:

- **Explant Selection and Sterilization:** A piece of plant tissue (explant) is chosen from a suitable high-yielding plant species.[4][5]
- **Callus Induction:** The explant is placed on a solid nutrient medium with plant growth regulators to induce the formation of an undifferentiated cell mass called a callus.[6]
- **Establishment of Suspension Culture:** Friable (loosely aggregated) portions of the callus are transferred to a liquid medium and agitated to establish a cell suspension culture.[4][7]
- **Growth Phase:** The cell suspension is cultured under optimal conditions to achieve a high cell density.
- **Elicitation and Production Phase:** Once sufficient biomass is achieved, elicitors are added to the culture to trigger the secondary metabolic pathway, leading to the synthesis and accumulation of **(+)-Scoulerine**. [2]
- **Extraction and Purification:** The cells and/or medium are harvested to extract and purify the target compound.

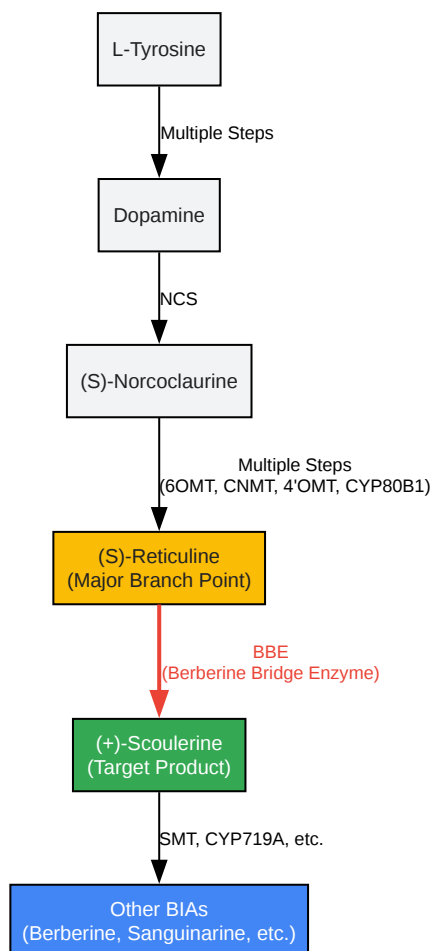
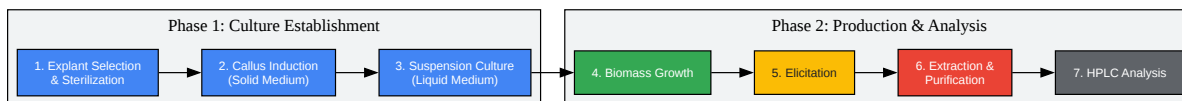

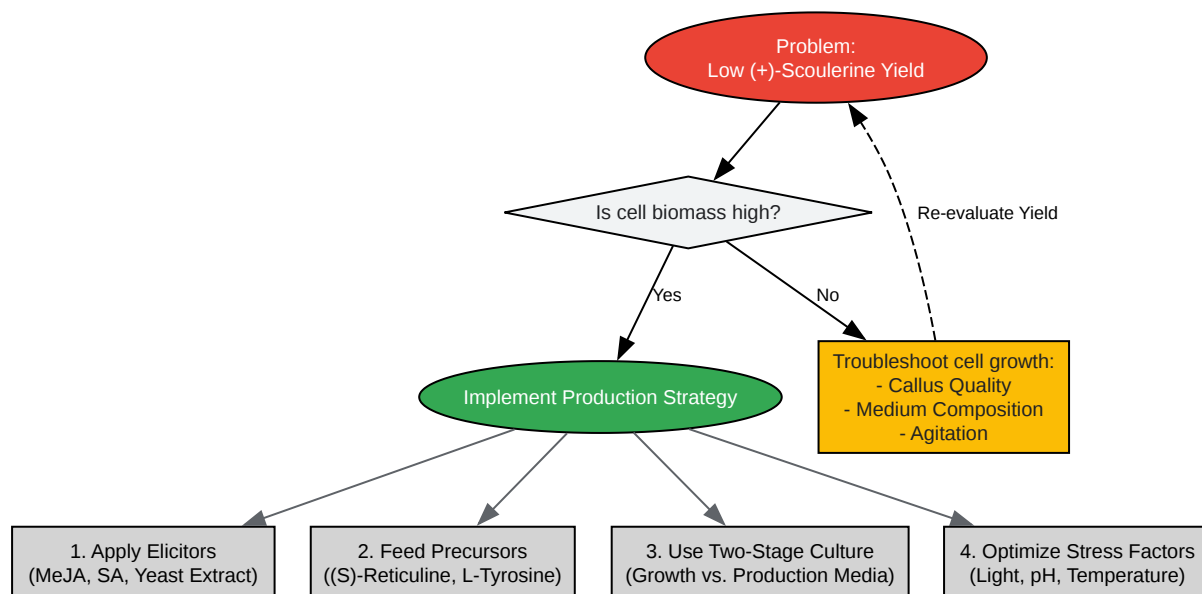

[Click to download full resolution via product page](#)

Need Custom Synthesis?

BenchChem offers custom synthesis for rare earth carbides and specific isotopic labeling.

Email: info@benchchem.com or [Request Quote Online](#).

References

- 1. benchchem.com [benchchem.com]
- 2. openscholar.dut.ac.za [openscholar.dut.ac.za]
- 3. Plant cell culture technologies: A promising alternatives to produce high-value secondary metabolites - Arabian Journal of Chemistry [arabjchem.org]
- 4. goldbio.com [goldbio.com]
- 5. goldbio.com [goldbio.com]
- 6. pjoes.com [pjoes.com]
- 7. CELL SUSPENSION CULTURE AND SECONDARY METABOLITES.pptx [slideshare.net]

- To cite this document: BenchChem. [Optimizing culture conditions for plant cell suspension to produce (+)-Scoulerine.]. BenchChem, [2025]. [Online PDF]. Available at: [https://www.benchchem.com/product/b1224586#optimizing-culture-conditions-for-plant-cell-suspension-to-produce-scoulerine]

Disclaimer & Data Validity:

The information provided in this document is for Research Use Only (RUO) and is strictly not intended for diagnostic or therapeutic procedures. While BenchChem strives to provide accurate protocols, we make no warranties, express or implied, regarding the fitness of this product for every specific experimental setup.

Technical Support: The protocols provided are for reference purposes. Unsure if this reagent suits your experiment? [[Contact our Ph.D. Support Team for a compatibility check](#)]

Need Industrial/Bulk Grade? [Request Custom Synthesis Quote](#)

BenchChem

Our mission is to be the trusted global source of essential and advanced chemicals, empowering scientists and researchers to drive progress in science and industry.

Contact

Address: 3281 E Guasti Rd

Ontario, CA 91761, United States

Phone: (601) 213-4426

Email: info@benchchem.com