

# Application Notes and Protocols for Cell-Based Assays Involving Phenylglyoxylate Treatment

**Author:** BenchChem Technical Support Team. **Date:** December 2025

## Compound of Interest

Compound Name: Phenylglyoxylate

Cat. No.: B1224774

[Get Quote](#)

For Researchers, Scientists, and Drug Development Professionals

## Introduction

**Phenylglyoxylate**, a metabolite of styrene, has garnered interest in cell-based research due to its potential to modulate key cellular metabolic pathways.[1] Cancer cells often exhibit altered metabolism, characterized by a preference for glycolysis even in the presence of oxygen, a phenomenon known as the Warburg effect.[2][3][4] This metabolic shift is largely regulated by the enzymes Lactate Dehydrogenase (LDH) and Pyruvate Dehydrogenase Kinase (PDK).[5][6] [7] **Phenylglyoxylate**, due to its structural similarity to pyruvate, is hypothesized to interfere with these pathways, making it a compound of interest for cancer research and drug development.

These application notes provide detailed protocols for a panel of cell-based assays to investigate the cytotoxic and apoptotic effects of **phenylglyoxylate**. Furthermore, we present methods to assess its potential inhibitory effects on LDH and PDK activity. As there is limited published data on the specific cellular effects of **phenylglyoxylate**, the following protocols are presented as a comprehensive guide for the empirical determination of its biological activity.

## Data Presentation: Quantitative Analysis of Phenylglyoxylate's Cellular Effects

Quantitative data from the described assays should be meticulously recorded and organized to allow for robust analysis and comparison. The following tables provide a template for summarizing key findings.

Table 1: Cytotoxicity of **Phenylglyoxylate** in Various Cancer Cell Lines

Cell Line	Treatment Duration (hours)	Phenylglyoxylate Concentration ( $\mu\text{M}$ )	Cell Viability (%) (Mean $\pm$ SD)	IC50 ( $\mu\text{M}$ )
MCF-7	24	0 (Vehicle Control)	100 $\pm$ 5.2	
		10		
		50		
		100		
		250		
		500		
	48	0 (Vehicle Control)	100 $\pm$ 4.8	
		10		
		50		
		100		
		250		
		500		
A549	24	0 (Vehicle Control)	100 $\pm$ 6.1	
		10		
		50		
		100		
		250		
		500		
	48	0 (Vehicle Control)	100 $\pm$ 5.5	

10
50
100
250
500

Table 2: Apoptosis Induction by **Phenylglyoxylate**

Cell Line	Treatment	Viable Cells (%) (Annexin V- / PI-)	Early Apoptotic Cells (%) (Annexin V+ / PI-)	Late Apoptotic/Necrotic Cells (%) (Annexin V+ / PI+)
MCF-7	Vehicle Control			
	Phenylglyoxylate (IC50 concentration)			
	Phenylglyoxylate (2x IC50 concentration)			
A549	Vehicle Control			
	Phenylglyoxylate (IC50 concentration)			
	Phenylglyoxylate (2x IC50 concentration)			

Table 3: Effect of **Phenylglyoxylate** on LDH and PDK Activity

Assay	Cell Line	Treatment	LDH Activity (% of Control)	PDK Activity (% of Control)
LDH Activity	MCF-7	Vehicle Control	100	N/A
Phenylglyoxylate (IC50)	N/A			
PDK Activity	A549	Vehicle Control	N/A	100
Phenylglyoxylate (IC50)	N/A			

## Signaling Pathways and Experimental Workflows

To visualize the underlying biological processes and experimental designs, the following diagrams are provided.

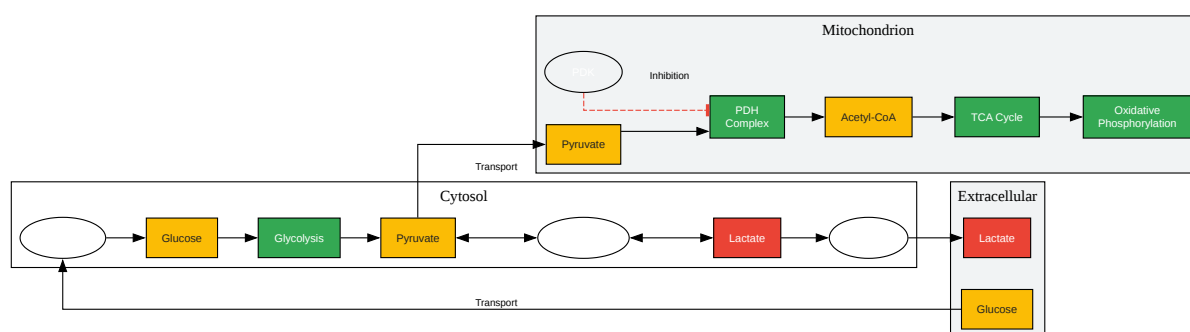

[Click to download full resolution via product page](#)

The Warburg Effect in Cancer Cells.

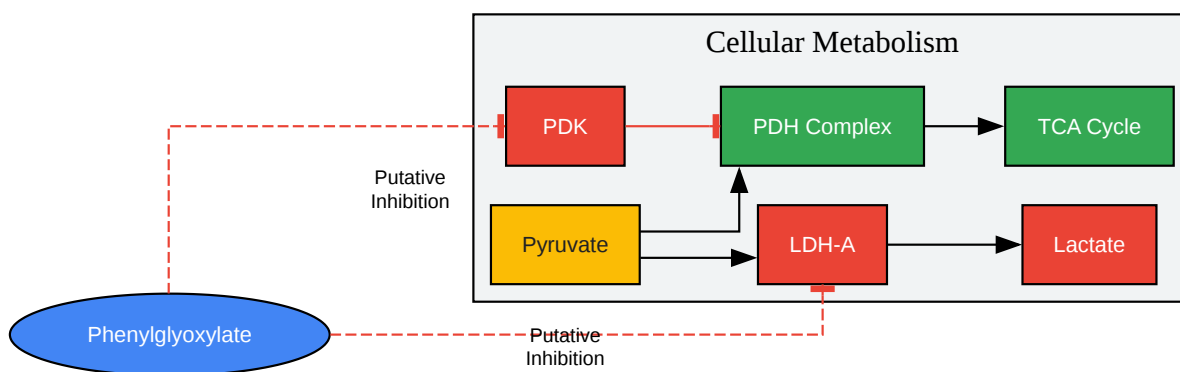
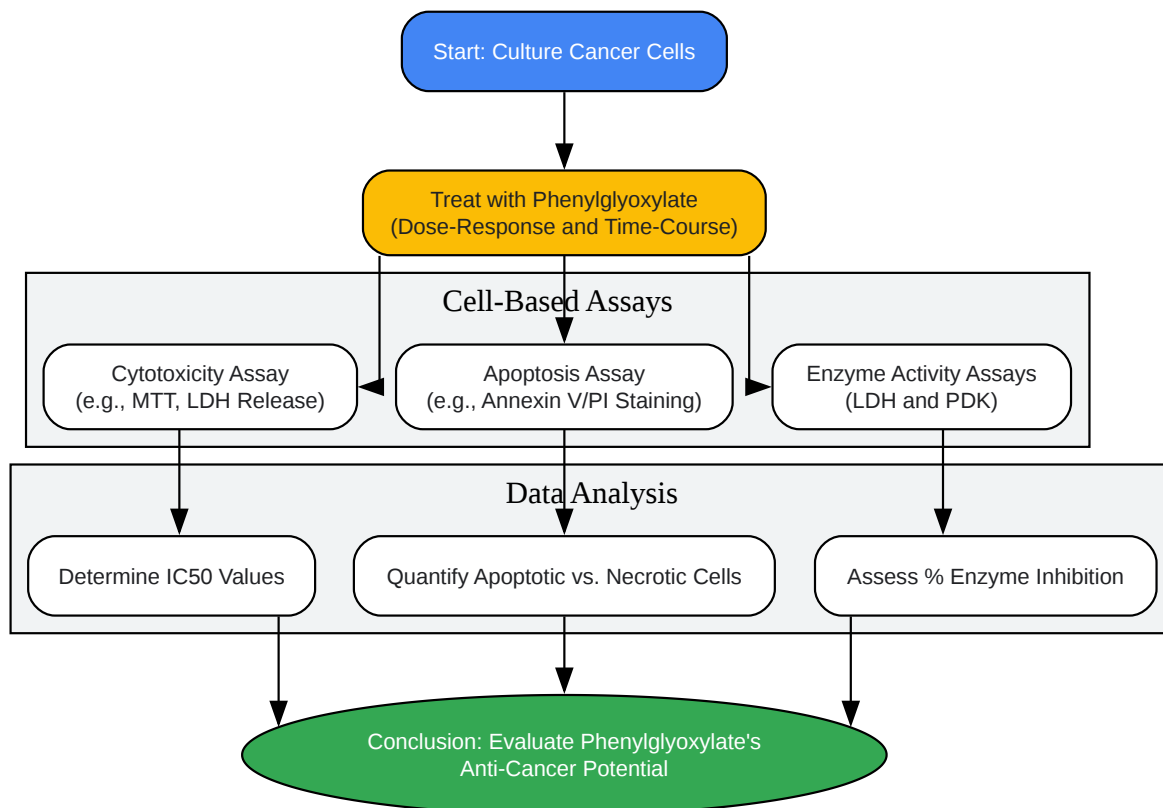

[Click to download full resolution via product page](#)

**Need Custom Synthesis?**

BenchChem offers custom synthesis for rare earth carbides and specific isotopic labeling.

Email: [info@benchchem.com](mailto:info@benchchem.com) or [Request Quote Online](#).

## References

- 1. bosterbio.com [bosterbio.com]
- 2. Reactome | Regulation of pyruvate dehydrogenase (PDH) complex [reactome.org]
- 3. portlandpress.com [portlandpress.com]
- 4. Apoptosis-inducing Plant-based Phenolic Compounds are Effective on Leukemia Cell Lines - PubMed [pubmed.ncbi.nlm.nih.gov]
- 5. Pyruvate dehydrogenase kinase - Wikipedia [en.wikipedia.org]
- 6. aacrjournals.org [aacrjournals.org]
- 7. The Regulation and Function of Lactate Dehydrogenase A: Therapeutic Potential in Brain Tumor - PMC [pmc.ncbi.nlm.nih.gov]
- To cite this document: BenchChem. [Application Notes and Protocols for Cell-Based Assays Involving Phenylglyoxylate Treatment]. BenchChem, [2025]. [Online PDF]. Available at: [https://www.benchchem.com/product/b1224774#cell-based-assays-involving-phenylglyoxylate-treatment]

---

**Disclaimer & Data Validity:**

The information provided in this document is for Research Use Only (RUO) and is strictly not intended for diagnostic or therapeutic procedures. While BenchChem strives to provide accurate protocols, we make no warranties, express or implied, regarding the fitness of this product for every specific experimental setup.

**Technical Support:** The protocols provided are for reference purposes. Unsure if this reagent suits your experiment? [[Contact our Ph.D. Support Team for a compatibility check](#)]

**Need Industrial/Bulk Grade?** [Request Custom Synthesis Quote](#)

# BenchChem

Our mission is to be the trusted global source of essential and advanced chemicals, empowering scientists and researchers to drive progress in science and industry.

## Contact

Address: 3281 E Guasti Rd

Ontario, CA 91761, United States

Phone: (601) 213-4426

Email: [info@benchchem.com](mailto:info@benchchem.com)