

Synthesis of long oligonucleotides using Ac-dC fast deprotection chemistry

Author: BenchChem Technical Support Team. **Date:** April 2026

Compound of Interest

Compound Name: *Ac-dACEphosphoramidite*

Cat. No.: *B12221528*

[Get Quote](#)

Application Note: High-Fidelity Synthesis of Long Oligonucleotides using Ac-dC Fast Deprotection Chemistry

Part 1: Executive Summary & Rationale

The synthesis of long oligonucleotides (100–200+ mers) presents a unique kinetic challenge: maintaining coupling efficiency while minimizing the accumulation of acid-catalyzed depurination and base-modification side reactions. Standard phosphoramidite chemistry utilizing Benzoyl-protected Cytosine (Bz-dC) and Isobutyryl-protected Guanine (iBu-dG) necessitates prolonged deprotection in concentrated ammonium hydroxide (typically 55°C for 16 hours).

For long oligonucleotides, this prolonged heat exposure is detrimental. It converts apurinic/apyrimidinic (AP) sites—generated by repeated acid exposure during the synthesis cycle—into strand cleavages, drastically reducing the yield of full-length product.

The Solution: The use of Acetyl-protected dC (Ac-dC) combined with AMA (1:1 Ammonium Hydroxide/Methylamine) deprotection.^{[1][2][3][4]} This chemistry allows for:

- Rapid Deprotection: Complete base removal in 10 minutes at 65°C.

- Prevention of Transamidation: Ac-dC eliminates the formation of N4-methyl-dC, a common mutation seen when Bz-dC is exposed to methylamine.[1][4]
- Preservation of Integrity: Reduced thermal exposure significantly lowers the rate of strand cleavage at abasic sites.

Part 2: Scientific Foundation

The Transamidation Problem (Bz-dC vs. Ac-dC)

The primary barrier to using fast-acting methylamine (in AMA) with standard chemistry is the transamidation of Cytosine.

- Bz-dC Mechanism: The benzoyl group is relatively stable.[1] Methylamine, being a strong nucleophile, attacks the carbonyl carbon of the benzoyl group. A competing reaction occurs where methylamine displaces the benzamide entirely, resulting in N4-methyl-cytosine. This is a stable mutation that disrupts Watson-Crick pairing.
- Ac-dC Mechanism: The acetyl group is far more labile. Hydrolysis by methylamine is instantaneous, occurring orders of magnitude faster than the displacement of the exocyclic amine. This ensures quantitative conversion to native Cytosine without side products.

Depurination Kinetics

Depurination (loss of A or G bases) occurs primarily during the detritylation step (acid contact). However, the consequence of depurination—strand scission—is base-catalyzed and heat-dependent.

- Standard Ammonia (16h @ 55°C): High probability of cleaving the sugar-phosphate backbone at any pre-existing abasic site.
- AMA (10min @ 65°C): The brief thermal window preserves the backbone integrity even if minor depurination occurred during synthesis, allowing the isolation of full-length (albeit potentially abasic) material which is often preferable to fragmented failure sequences.

Part 3: Visualization of Mechanisms & Workflow

Figure 1: Comparative Deprotection Pathways

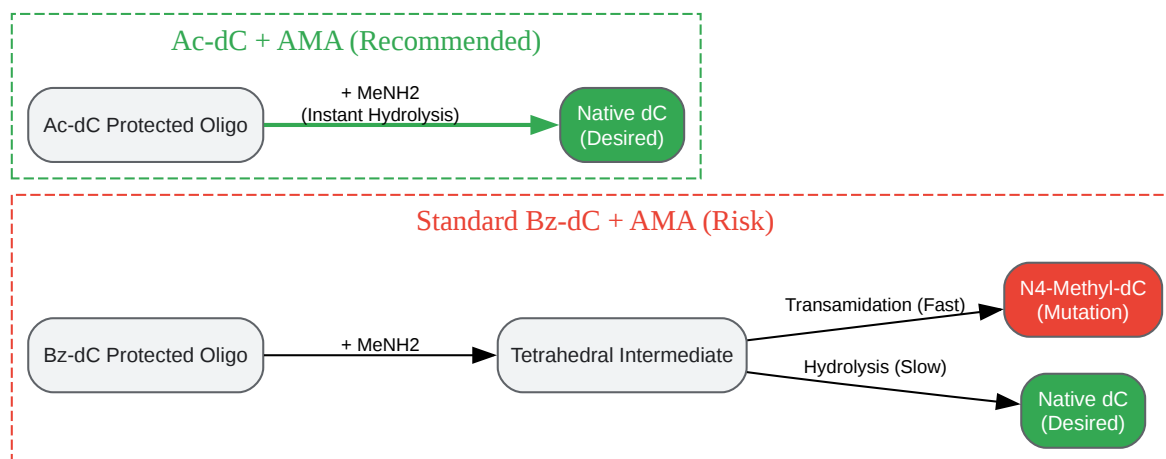

[Click to download full resolution via product page](#)

Caption: Comparison of reaction pathways. Bz-dC carries a high risk of mutation (N4-Methyl-dC) in AMA, whereas Ac-dC yields exclusively native Cytosine.

Figure 2: Long Oligonucleotide Synthesis Workflow

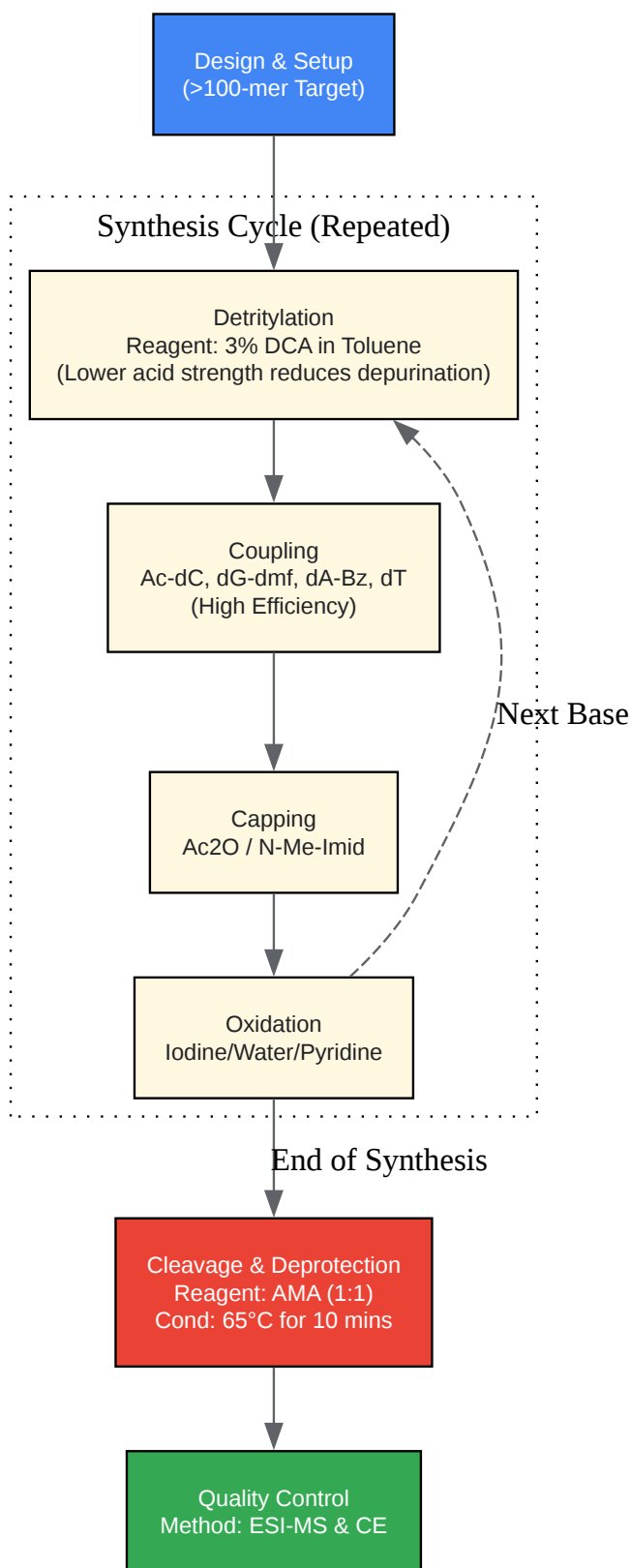

[Click to download full resolution via product page](#)

Caption: Optimized workflow for long oligos. Note the use of DCA for detritylation and AMA for rapid thermal deprotection.

Part 4: Experimental Protocol

Reagent Selection

For synthesis of oligonucleotides >60 bases, strict adherence to these reagent choices is required to validate this protocol.

Component	Recommendation	Rationale
dC Monomer	Ac-dC (Acetyl-dC)	Mandatory. Prevents transamidation with methylamine.[1][4]
dG Monomer	dG-dmf (Dimethylformamidine)	Preferred over iBu-dG.[3][5][6] Deprotects faster and is more stable to depurination.
dA Monomer	dA-Bz (Benzoyl)	Standard protection is compatible with AMA.
Detritylation	3% DCA in Toluene/DCM	Dichloroacetic acid (pKa ~1.5) is milder than TCA (pKa ~0.7), reducing acid-catalyzed depurination during long cycles.
Activator	ETT or DCI	Higher nucleophilicity improves coupling efficiency for long chains.

Synthesis Cycle Parameters

- Coupling Time: Increase coupling time to 120–180 seconds for strands >60-mer to ensure maximum efficiency.
- Capping: Ensure "Cap A" and "Cap B" delivery is robust. Incomplete capping leads to deletion mutants (N-1, N-2) which are impossible to purify from long oligos.

AMA Deprotection Protocol (The "UltraFAST" Method)

Safety: Work in a fume hood. AMA generates methylamine gas which is toxic and has a strong odor.

- Preparation of AMA:
 - Mix Ammonium Hydroxide (30%) and Aqueous Methylamine (40%) in a 1:1 ratio (v/v).
 - Note: Prepare fresh or store tightly capped at 4°C. Methylamine is volatile; loss of concentration affects deprotection.
- Cleavage (Manual or On-Instrument):
 - Flush the synthesis column with AMA (~1–2 mL depending on scale).
 - Allow to stand for 5 minutes at Room Temperature. This cleaves the oligo from the CPG support.[7]
 - Elute the oligo into a screw-cap vial (glass or polypropylene compatible with high heat).
- Deprotection (Heating):
 - Seal the vial tightly.
 - Incubate at 65°C for 10 minutes.
 - Warning: Do not exceed 15 minutes. Extended heating re-introduces the risk of strand cleavage.
- Work-up:
 - Cool the vial on ice to condense vapors.
 - Carefully open the vial (pressure release).
 - Evaporate to dryness using a SpeedVac or lyophilizer.

Alternative Conditions Matrix

If 65°C is not feasible (e.g., presence of heat-sensitive dyes), use the following:

Condition	Temp	Time	Notes
Standard AMA	65°C	10 min	Optimal for long oligos (Ac-dC required).[3][6]
Mild AMA	RT (22°C)	2–3 hours	Sufficient for Ac-dC/dG-dmf. Not recommended for iBu-dG.
Ammonia	55°C	4–8 hours	Compatible with Ac-dC, but risks higher depurination damage.

Part 5: Troubleshooting & Quality Control

Analyzing Long Oligos

- Mass Spectrometry (ESI-MS): Look for the +53 Da shift.[8]
 - Cause: Acrylonitrile adduct (from cyanoethyl group removal) reacting with Thymine (N3-cyanoethylation).
 - Fix: AMA is naturally a better scavenger of acrylonitrile than ammonia, but ensure the AMA volume is sufficient (at least 10x support volume).
- Capillary Electrophoresis (CE): Preferred over HPLC for long oligos (>60-mer) due to better resolution of N-1 failure sequences.

Common Issues

- Problem: Presence of N4-Methyl-dC peaks (mass +14 Da relative to C).
 - Root Cause:[2][3][4][5][6][8][9] Use of Bz-dC instead of Ac-dC with AMA.
 - Solution: Verify reagent bottle labels. You must use Ac-dC.[1][2][6]

- Problem: Low yield of full-length product despite good coupling scores.
 - Root Cause:[2][3][4][5][6][8][9] Depurination-induced cleavage during deprotection.[10]
 - Solution: Switch from TCA to DCA for detritylation; ensure deprotection time at 65°C does not exceed 10-15 mins.

References

- Glen Research. (n.d.). UltraFAST Deprotection - Glen Report 25.14. Retrieved from [[Link](#)]
- Reddy, M. P., et al. (1994). Fast cleavage and deprotection of oligonucleotides. Tetrahedron Letters, 35(25), 4311-4314.
- ATDBio. (n.d.). Solid-phase oligonucleotide synthesis - Deprotection. Retrieved from [[Link](#)]
- LeProust, E. M., et al. (2010). Synthesis of high-quality libraries of long (150mer) oligonucleotides by a novel depurination controlled process. Nucleic Acids Research, 38(8), 2522–2540. Retrieved from [[Link](#)]

Need Custom Synthesis?

BenchChem offers custom synthesis for rare earth carbides and specific isotopic labeling.

Email: info@benchchem.com or [Request Quote Online](#).

Sources

- 1. [benchchem.com](https://www.benchchem.com) [[benchchem.com](https://www.benchchem.com)]
- 2. [glenresearch.com](https://www.glenresearch.com) [[glenresearch.com](https://www.glenresearch.com)]
- 3. [glenresearch.com](https://www.glenresearch.com) [[glenresearch.com](https://www.glenresearch.com)]
- 4. [glenresearch.com](https://www.glenresearch.com) [[glenresearch.com](https://www.glenresearch.com)]
- 5. [Fast Deprotection](https://www.qualitysystems.com.tw) [[qualitysystems.com.tw](https://www.qualitysystems.com.tw)]
- 6. [glenresearch.com](https://www.glenresearch.com) [[glenresearch.com](https://www.glenresearch.com)]
- 7. [researchgate.net](https://www.researchgate.net) [[researchgate.net](https://www.researchgate.net)]
- 8. [glenresearch.com](https://www.glenresearch.com) [[glenresearch.com](https://www.glenresearch.com)]

- [9. glenresearch.com \[glenresearch.com\]](https://www.glenresearch.com)
- [10. blog.biosearchtech.com \[blog.biosearchtech.com\]](https://www.blog.biosearchtech.com)
- To cite this document: BenchChem. [Synthesis of long oligonucleotides using Ac-dC fast deprotection chemistry]. BenchChem, [2026]. [Online PDF]. Available at: [\[https://www.benchchem.com/product/b12221528/docs#synthesis-of-long-oligonucleotides-using-ac-dc-fast-deprotection-chemistry\]](https://www.benchchem.com/product/b12221528/docs#synthesis-of-long-oligonucleotides-using-ac-dc-fast-deprotection-chemistry)

Disclaimer & Data Validity:

The information provided in this document is for Research Use Only (RUO) and is strictly not intended for diagnostic or therapeutic procedures. While BenchChem strives to provide accurate protocols, we make no warranties, express or implied, regarding the fitness of this product for every specific experimental setup.

Technical Support: The protocols provided are for reference purposes. Unsure if this reagent suits your experiment?

Need Industrial/Bulk Grade? [Request Custom Synthesis Quote](#)

BenchChem

Our mission is to be the trusted global source of essential and advanced chemicals, empowering scientists and researchers to drive progress in science and industry.

Contact

Address: 3281 E Guasti Rd
Ontario, CA 91761, United States
Phone: (601) 213-4426
Email: info@benchchem.com

[Contact our Ph.D. Support Team for a compatibility check](#)