

Structure-activity relationship of alkylated phenols

Author: BenchChem Technical Support Team. **Date:** May 2026

Compound of Interest

Compound Name: *2-tert-Butyl-4-ethylphenol*

CAS No.: 96-70-8

Cat. No.: B1222043

[Get Quote](#)

An In-depth Technical Guide to the Structure-Activity Relationship of Alkylated Phenols

For Researchers, Scientists, and Drug Development Professionals

Introduction

Alkylated phenols, a significant class of organic compounds, are characterized by a hydroxyl group attached to a benzene ring, which is further substituted with one or more alkyl groups.^[1]^[2] This seemingly simple structural motif gives rise to a remarkable diversity of biological activities, making them crucial molecules in fields ranging from pharmacology and food science to industrial chemistry.^[3]^[4] They are widely recognized for their antioxidant, antibacterial, and cytotoxic properties.^[2]^[5] The efficacy of these activities is not static; it is intricately linked to the specific architecture of the alkyl substituent(s). Understanding the structure-activity relationship (SAR) of alkylated phenols is paramount for the rational design of novel therapeutic agents, more effective food preservatives, and specialized industrial chemicals. This guide provides a comprehensive exploration of the core principles governing the SAR of alkylated phenols, delving into their synthesis, mechanisms of action, and the experimental and computational methodologies used to evaluate them.

The Chemical Foundation of Activity: The Phenolic Moiety

The biological activity of alkylated phenols fundamentally originates from the phenolic hydroxyl (-OH) group. This group can readily donate a hydrogen atom to neutralize free radicals, which are highly reactive species implicated in oxidative stress and cellular damage.^{[6][7]} This radical scavenging ability is the cornerstone of their antioxidant action and influences their other biological effects.

The primary mechanisms by which phenols exert their antioxidant effects are:

- **Hydrogen Atom Transfer (HAT):** The phenolic hydroxyl group donates its hydrogen atom to a free radical, thereby quenching the radical's reactivity.^{[8][9]} The resulting phenoxyl radical is relatively stable due to the delocalization of the unpaired electron across the aromatic ring.^[6]
- **Single Electron Transfer followed by Proton Transfer (SET-PT):** In this mechanism, the phenol first donates an electron to the free radical, forming a radical cation. This is followed by the transfer of a proton to a solvent molecule.^{[8][9]}

The stability of the resulting phenoxyl radical is a critical determinant of the antioxidant capacity. Electron-donating groups on the aromatic ring, such as alkyl groups, can further stabilize this radical, thereby enhancing the antioxidant activity.^[10]

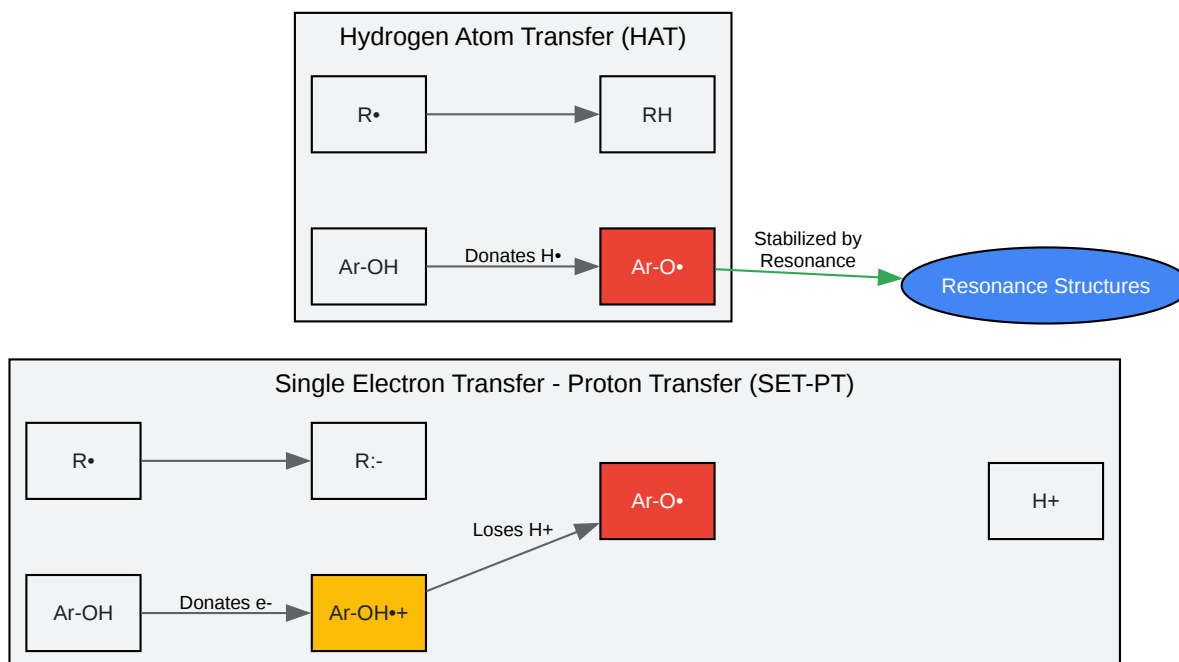

[Click to download full resolution via product page](#)

Caption: Antioxidant Mechanisms of Phenolic Compounds.

Synthesis of Alkylated Phenols

The introduction of alkyl groups onto a phenolic ring is most commonly achieved through electrophilic aromatic substitution, particularly Friedel-Crafts alkylation.[1] This method involves reacting a phenol with an alkylating agent (e.g., an alkene or an alcohol) in the presence of an acidic catalyst.[3] The position of alkylation (ortho or para to the hydroxyl group) can be controlled by the choice of catalyst and reaction conditions.[11]

Experimental Protocol: Synthesis of ortho-Alkylated Phenol

This protocol describes a representative synthesis of an ortho-alkylated phenol using a ruthenium-hydride catalyst, which offers high regioselectivity.[11]

- Preparation: In a nitrogen-filled glovebox, add phenol (1.0 mmol), an alcohol (1.2 mmol), cyclopentene (0.1 mmol as a hydrogen acceptor), and a cationic Ru-H complex catalyst (1 mol %) to a vial.
- Solvent Addition: Add 2 mL of toluene to the vial.
- Reaction: Seal the vial and remove it from the glovebox. Place the vial in a preheated oil bath at 100 °C.
- Monitoring: Stir the reaction mixture for the specified time (e.g., 8-12 hours), monitoring the progress by thin-layer chromatography (TLC) or gas chromatography (GC).
- Work-up: After the reaction is complete, cool the mixture to room temperature. Remove the solvent under reduced pressure.
- Purification: Purify the crude product by column chromatography on silica gel to obtain the desired ortho-alkylated phenol.[\[11\]](#)

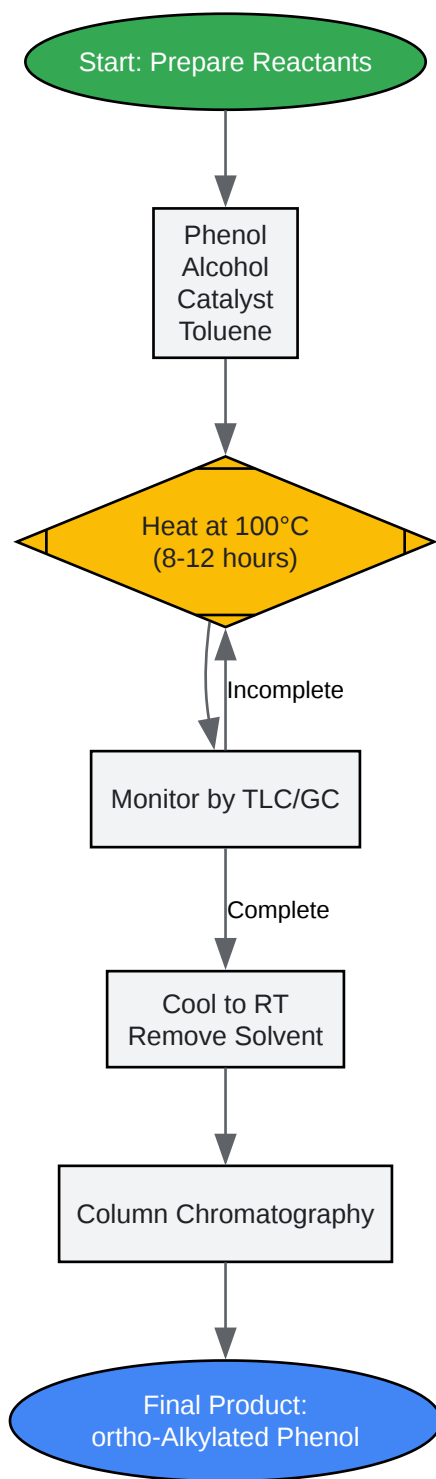

[Click to download full resolution via product page](#)

Caption: Workflow for the Synthesis of *ortho*-Alkylated Phenols.

Deep Dive into Structure-Activity Relationships

The biological activity of alkylated phenols is profoundly influenced by the nature of the alkyl substituent, including its length, branching (steric hindrance), and position on the aromatic ring.

Antioxidant Activity

The antioxidant potency of alkylated phenols is a delicate balance between the electron-donating effect of the alkyl group and steric factors.

- **Alkyl Group Position:** Alkyl groups in the ortho and para positions to the hydroxyl group generally increase antioxidant activity more than those in the meta position. This is because they can more effectively stabilize the phenoxyl radical through resonance and inductive effects.
- **Steric Hindrance:** Bulky alkyl groups, such as tert-butyl, at the ortho positions can enhance antioxidant activity by sterically hindering the reactive phenoxyl radical, preventing it from participating in undesirable side reactions.^[10] However, excessive steric hindrance can also impede the approach of the phenol to the target radical, thus reducing activity.
- **Chain Length and Branching:** Increasing the alkyl chain length can have varied effects. While longer chains might increase lipophilicity, aiding interaction with lipid radicals, they don't always lead to higher activity. The presence of an α -hydrogen in the alkyl substituent can contribute to radical scavenging, with substituents having a lower α -C-H bond dissociation energy (e.g., isopropyl) showing enhanced activity.^[10]

Compound	Alkyl Substituent(s)	Antioxidant Activity (Relative)	Reference
Phenol	None	Baseline	[12]
2,6-di-tert-butyl-4-methylphenol (BHT)	2,6-di-tert-butyl, 4-methyl	High	[10]
2,6-diisopropyl-4-methylphenol	2,6-diisopropyl, 4-methyl	Very High	[10]
4-nonylphenol	4-nonyl	Moderate	[1]

Antibacterial Activity

The antibacterial properties of alkylated phenols are strongly correlated with their lipophilicity, which is dictated by the alkyl chain.[5]

- **Gram-Positive vs. Gram-Negative Bacteria:** Alkylated phenols are often more effective against Gram-positive bacteria. The lipophilic alkyl chain facilitates the disruption of the bacterial cytoplasmic membrane.[13] Gram-negative bacteria possess an additional outer membrane that acts as a barrier, making them less susceptible.
- **Alkyl Chain Length:** There is often an optimal alkyl chain length for maximum antibacterial activity. For instance, studies on caffeic acid alkyl esters have shown that longer alkyl chains are more effective against the Gram-positive *S. aureus*, while medium-length chains are more potent against the Gram-negative *E. coli*. [5][14] This suggests that a balance of hydrophobicity is needed to traverse the different bacterial cell wall structures.

Compound Class	Alkyl Chain Length	Activity vs. <i>S. aureus</i> (Gram+)	Activity vs. <i>E. coli</i> (Gram-)	Reference
Caffeic Acid Esters	Short	Low	Low	[5][14]
Caffeic Acid Esters	Medium	Moderate	High	[5][14]
Caffeic Acid Esters	Long	High	Low	[5][14]

Cytotoxicity and Apoptosis

The cytotoxicity of alkylated phenols is a complex interplay of hydrophobicity, steric effects, and electronic properties.[15]

- **Hydrophobicity:** Increased lipophilicity (higher log P) often leads to greater cytotoxicity, as it enhances the compound's ability to cross cell membranes and interact with intracellular targets.[15] For some phenols, cytotoxicity is critically dependent on hydrophobicity.[15]
- **Steric Factors:** The size and shape of the alkyl groups play a crucial role. Quantitative structure-activity relationship (QSAR) models have shown that steric parameters are strong

predictors of apoptosis-inducing activity, suggesting a receptor-mediated interaction.[15]

- Electronic Effects: For electron-releasing phenols, radical stabilization is a key factor in their cytotoxic mechanism.[15]

Compound Class	Key SAR Descriptors	Biological Effect	Reference
Substituted Phenols	Steric parameters (B5), Hydrophobicity (π)	Caspase-mediated apoptosis	[15]
Electron-releasing Phenols	Electronic ($\sigma+$), Steric (B5), Hydrophobicity (log P)	Cytotoxicity	[15]
Electron-attracting Phenols	Hydrophobicity (log P), Steric (B5)	Cytotoxicity	[15]

Experimental Evaluation of Alkylated Phenols

A thorough evaluation of alkylated phenols requires both analytical characterization and biological activity assays.

Analytical Characterization

Techniques like Gas Chromatography-Mass Spectrometry (GC-MS) and Liquid Chromatography-Mass Spectrometry (LC-MS) are essential for the identification and quantification of alkylated phenols.[16][17] These methods allow for the separation of complex mixtures of isomers and provide structural information based on mass-to-charge ratios.

Protocols for Biological Assays

DPPH Radical Scavenging Assay

This widely used method assesses the ability of a compound to act as a free radical scavenger. [8][18]

- **Reagent Preparation:** Prepare a 0.1 mM solution of 2,2-diphenyl-1-picrylhydrazyl (DPPH) in methanol.^[18] Prepare stock solutions of the test compounds and a standard (e.g., Trolox) in methanol.
- **Reaction Mixture:** In a 96-well plate, add a specific volume of the test compound solution to the DPPH solution. For the control, add only methanol to the DPPH solution.
- **Incubation:** Incubate the plate in the dark at room temperature for 30 minutes.
- **Measurement:** Measure the absorbance of each well at 517 nm using a microplate reader.
- **Calculation:** The percentage of radical scavenging activity is calculated using the formula: % Inhibition = $[(\text{Absorbance of control} - \text{Absorbance of sample}) / \text{Absorbance of control}] \times 100$. The IC₅₀ value (the concentration required to scavenge 50% of the DPPH radicals) is then determined.

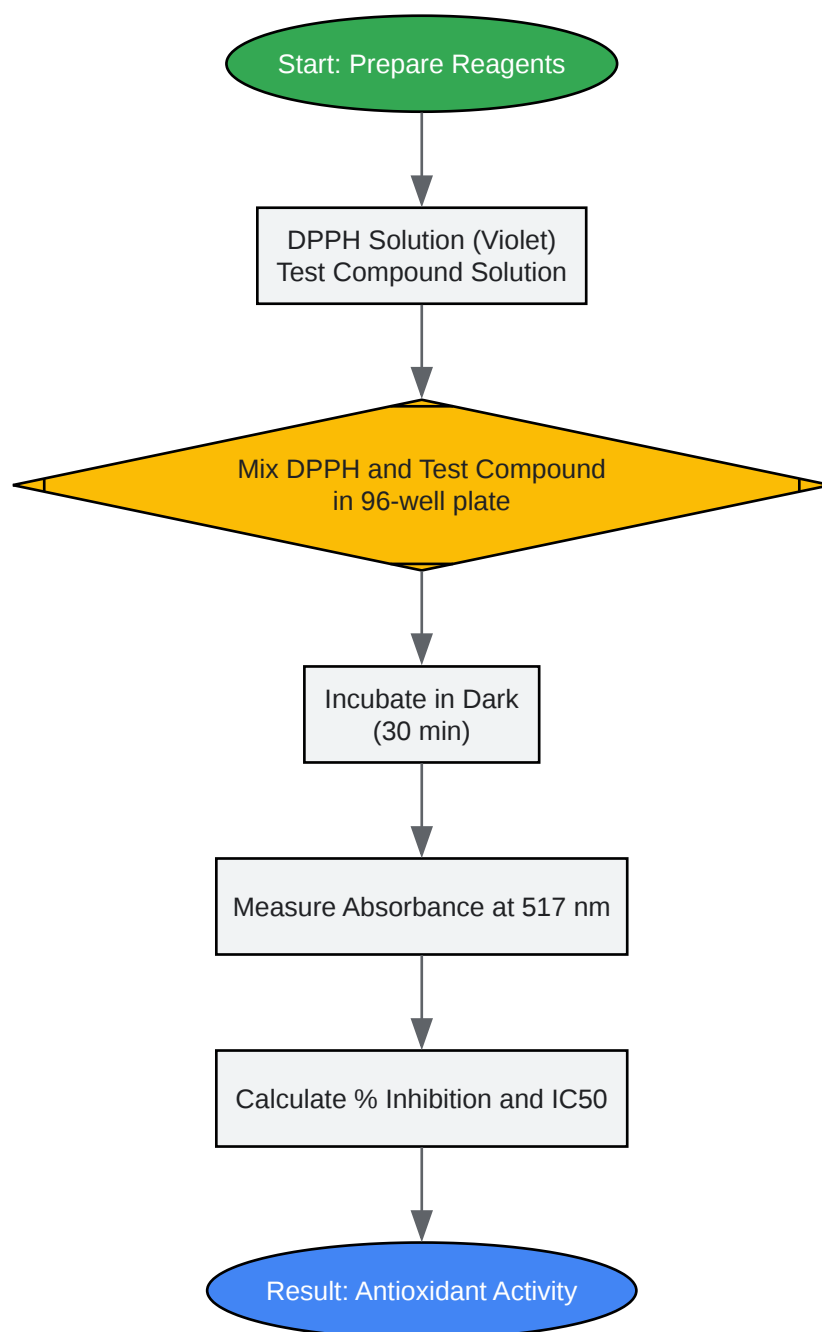

[Click to download full resolution via product page](#)

Caption: Workflow for the DPPH Radical Scavenging Assay.

Quantitative Structure-Activity Relationship (QSAR) Modeling

QSAR models are mathematical representations that correlate the chemical structure of compounds with their biological activity.^[19] For alkylated phenols, QSAR helps to predict the activity of novel compounds and to understand the underlying mechanisms.^{[12][20]}

Key descriptors used in QSAR models for alkylated phenols include:

- Hydrophobicity: Often represented by log P (the logarithm of the octanol-water partition coefficient).^[15]
- Electronic Descriptors: Such as Hammett constants (σ) or the energy of the highest occupied molecular orbital (HOMO).^[12]
- Steric Descriptors: Like molecular refractivity (MR) or STERIMOL parameters (e.g., B5).^[15]

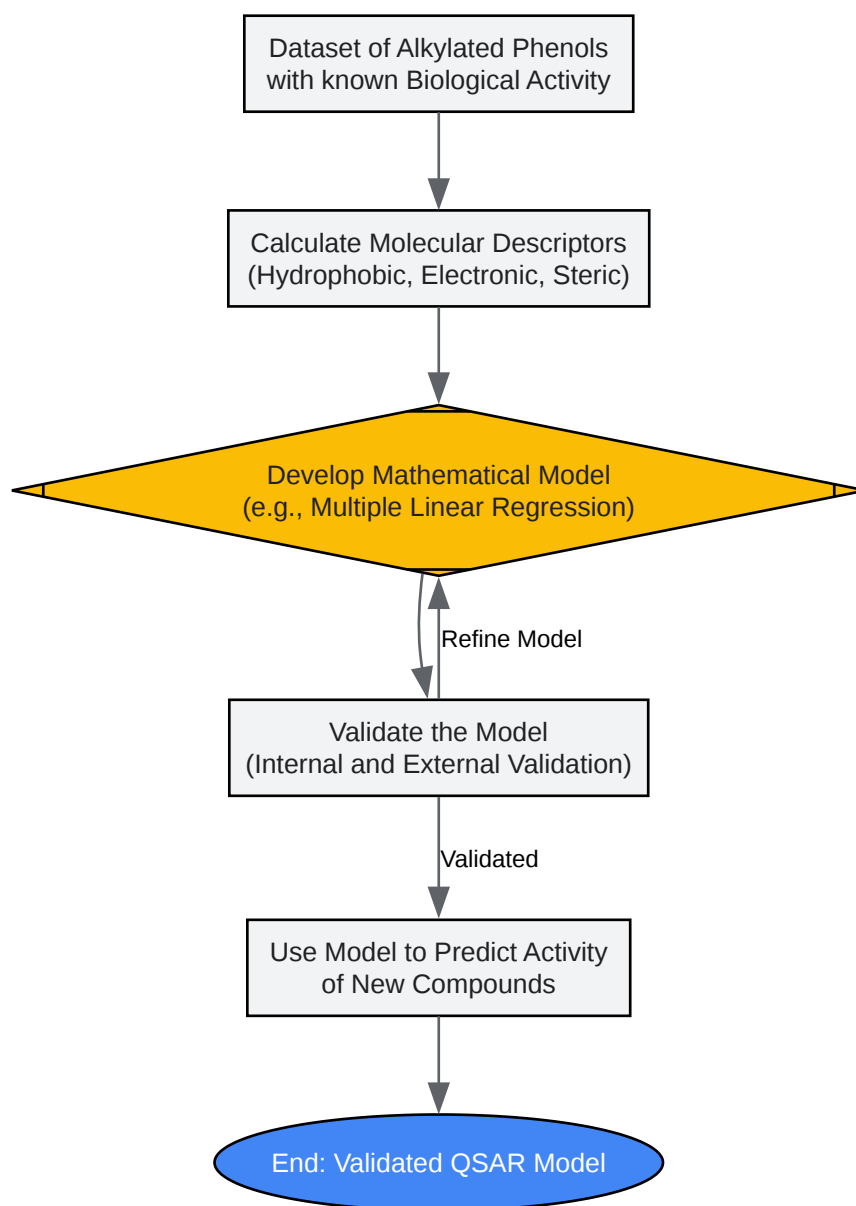

[Click to download full resolution via product page](#)

Caption: General Workflow for QSAR Modeling.

Conclusion and Future Perspectives

The structure-activity relationship of alkylated phenols is a multifaceted field where subtle changes in the alkyl substituent can lead to significant shifts in biological activity. Key takeaways include the enhancing effect of ortho and para alkyl groups on antioxidant activity, the critical role of lipophilicity in antibacterial action, and the complex interplay of hydrophobic, electronic, and steric factors in cytotoxicity. As our understanding of these relationships

deepens, the potential for designing highly specific and potent alkylated phenols for therapeutic and industrial applications continues to grow. Future research will likely focus on synthesizing novel derivatives with enhanced bioavailability and reduced toxicity, further exploring their mechanisms of action at the molecular level, and leveraging advanced computational models to accelerate the discovery process.

References

- Characterization of phenol and alkyl phenols in organic matrixes with monoethylene glycol extraction and multidimensional gas chromatography/mass spectrometry - PubMed. (2013-07-02). Retrieved from [\[Link\]](#)
- Dehydrative C–H Alkylation and Alkenylation of Phenols with Alcohols: Expedient Synthesis for Substituted Phenols and Benzofurans | Journal of the American Chemical Society - ACS Publications. (2012-04-11). Retrieved from [\[Link\]](#)
- Alkylphenol - Wikipedia. Retrieved from [\[Link\]](#)
- Alkyl Phenol Production Process. Retrieved from [\[Link\]](#)
- Quantitative structure-activity relationship analysis of phenolic antioxidants - PubMed. (1999-02). Retrieved from [\[Link\]](#)
- The Chemical Structure and Clinical Significance of Phenolic Compounds - International Journal of Health & Medical Research. (2024-10-10). Retrieved from [\[Link\]](#)
- Cellular apoptosis and cytotoxicity of phenolic compounds: a quantitative structure-activity relationship study - PubMed. (2005-11-10). Retrieved from [\[Link\]](#)
- Quantitative structure-activity relationships of antioxidant phenolic compounds - JOCPR. Retrieved from [\[Link\]](#)
- Antibacterial Properties of Polyphenols: Characterization and QSAR (Quantitative Structure–Activity Relationship) Models - PMC - NIH. (2019-04-18). Retrieved from [\[Link\]](#)
- Phenolic antioxidants. Effect of o-alkyl substituents (Journal Article) | ETDEWEB - OSTI. (1998-07-01). Retrieved from [\[Link\]](#)

- (PDF) Phenolic compounds: structures and activities - ResearchGate. (2021-06-30). Retrieved from [[Link](#)]
- Introduction of Alkyl Phenol Production Process. Retrieved from [[Link](#)]
- Quantitative structure-activity relationships of phenolic compounds causing apoptosis. (2003-02-20). Retrieved from [[Link](#)]
- The Structure–Antioxidant Activity Relationship of Ferulates - PMC - NIH. Retrieved from [[Link](#)]
- Phenol synthesis by substitution or oxidation - Organic Chemistry Portal. Retrieved from [[Link](#)]
- DPPH Radical Scavenging Assay - MDPI. Retrieved from [[Link](#)]
- Polyphenols as Antioxidant/Pro-Oxidant Compounds and Donors of Reducing Species: Relationship with Human Antioxidant Metabolism - MDPI. Retrieved from [[Link](#)]
- A Generalized Method for Determining Free Soluble Phenolic Acid Composition and Antioxidant Capacity of Cereals and Legumes - JoVE. (2021-04-20). Retrieved from [[Link](#)]
- How to assess antioxidant activity? Advances, limitations, and applications of in vitro, in vivo, and ex vivo approaches - PubMed Central. Retrieved from [[Link](#)]
- Assessing Antioxidant and Prooxidant Activities of Phenolic Compounds † | Request PDF. (2025-08-06). Retrieved from [[Link](#)]
- Quantitative structure-activity relationship for prediction of the toxicity of phenols on Photobacterium phosphoreum - PubMed. Retrieved from [[Link](#)]
- Antimicrobial Activity of Naturally Occurring Phenols and Derivatives Against Biofilm and Planktonic Bacteria - PMC - NIH. Retrieved from [[Link](#)]
- Tailored Functionalization of Natural Phenols to Improve Biological Activity - MDPI. Retrieved from [[Link](#)]

- QSAR Study on the toxicities of alcohols and phenols based on minimal redundancy maximal relevance and distance correlation feature selection methods - ResearchGate. (2025-08-10). Retrieved from [\[Link\]](#)
- Phenolic Compounds in Bacterial Inactivation: A Perspective from Brazil - MDPI. (2023-03-24). Retrieved from [\[Link\]](#)
- Future Antimicrobials: Natural and Functionalized Phenolics - MDPI. (2023-01-22). Retrieved from [\[Link\]](#)
- LC-MS Application Data Sheet No. 037 Analysis of Alkylphenols using LC-MS. Retrieved from [\[Link\]](#)
- Antioxidant Activity of Plant Phenols: Chemical Mechanisms and Biological Significance. Retrieved from [\[Link\]](#)
- Determination of alkylphenols and alkylphenol polyethoxylates by reversed-phase high-performance liquid chromatography and solid-phase extraction - ResearchGate. (2025-08-06). Retrieved from [\[Link\]](#)
- Trends in analytical methodologies for the determination of alkylphenols and bisphenol A in water samples. Retrieved from [\[Link\]](#)
- Biological activity of phenolic lipids - PMC - NIH. Retrieved from [\[Link\]](#)
- Quantitative structure–activity relationship - Wikipedia. Retrieved from [\[Link\]](#)
- Quantitative structure-activity relationships of antioxidant phenolic compounds - Journal of Chemical and Pharmaceutical Research. Retrieved from [\[Link\]](#)
- Antioxidant and structure–activity relationships (SARs) of some phenolic and anilines compounds - ResearchGate. (2025-10-09). Retrieved from [\[Link\]](#)
- Quantitative structure-activity relationships of antioxidant phenolic compounds. (2025-08-09). Retrieved from [\[Link\]](#)

- Importance of phenols structure on their activity as antinitrosating agents: A kinetic study. Retrieved from [[Link](#)]
- Quantitative structure-activity relationships in prooxidant cytotoxicity of polyphenols: Role of potential of phenoxy radical/phenol redox couple - ResearchGate. (2025-07-16). Retrieved from [[Link](#)]
- Relationship structure-antioxidant activity of hindered phenolic compounds - ResearchGate. Retrieved from [[Link](#)]
- Antibacterial Properties of Polyphenols: Characterization and QSAR (Quantitative Structure–Activity Relationship) Models - ResearchGate. (2019-04-18). Retrieved from [[Link](#)]
- Concept, mechanism, and applications of phenolic antioxidants in foods - PubMed. (2020-07-20). Retrieved from [[Link](#)]
- Correlation Between Total Phenols Content, Antioxidant Power and Cytotoxicity. Retrieved from [[Link](#)]
- Biological activity of phenolic lipids - PubMed. Retrieved from [[Link](#)]
- Biological Activities of Phenolic Compounds Present in Virgin Olive Oil - MDPI. Retrieved from [[Link](#)]

Need Custom Synthesis?

BenchChem offers custom synthesis for rare earth carbides and specific isotopic labeling.

Email: info@benchchem.com or [Request Quote Online](#).

Sources

- 1. Alkylphenol - Wikipedia [en.wikipedia.org]
- 2. ijhmr.com [ijhmr.com]
- 3. Introduction of Alkyl Phenol Production Process [slchemtech.com]
- 4. mdpi.com [mdpi.com]

- 5. Antibacterial Properties of Polyphenols: Characterization and QSAR (Quantitative Structure–Activity Relationship) Models - PMC [[pmc.ncbi.nlm.nih.gov](https://pubmed.ncbi.nlm.nih.gov)]
- 6. [mdpi.com](https://www.mdpi.com) [[mdpi.com](https://www.mdpi.com)]
- 7. [researchgate.net](https://www.researchgate.net) [[researchgate.net](https://www.researchgate.net)]
- 8. [mdpi.com](https://www.mdpi.com) [[mdpi.com](https://www.mdpi.com)]
- 9. Concept, mechanism, and applications of phenolic antioxidants in foods - PubMed [pubmed.ncbi.nlm.nih.gov]
- 10. Phenolic antioxidants. Effect of o-alkyl substituents (Journal Article) | ETDEWEB [osti.gov]
- 11. pubs.acs.org [pubs.acs.org]
- 12. Quantitative structure-activity relationship analysis of phenolic antioxidants - PubMed [pubmed.ncbi.nlm.nih.gov]
- 13. Antimicrobial Activity of Naturally Occurring Phenols and Derivatives Against Biofilm and Planktonic Bacteria - PMC [[pmc.ncbi.nlm.nih.gov](https://pubmed.ncbi.nlm.nih.gov)]
- 14. [mdpi.com](https://www.mdpi.com) [[mdpi.com](https://www.mdpi.com)]
- 15. Cellular apoptosis and cytotoxicity of phenolic compounds: a quantitative structure-activity relationship study - PubMed [pubmed.ncbi.nlm.nih.gov]
- 16. Characterization of phenol and alkyl phenols in organic matrixes with monoethylene glycol extraction and multidimensional gas chromatography/mass spectrometry - PubMed [pubmed.ncbi.nlm.nih.gov]
- 17. [lcms.cz](https://www.lcms.cz) [[lcms.cz](https://www.lcms.cz)]
- 18. pdf.benchchem.com [pdf.benchchem.com]
- 19. Quantitative structure–activity relationship - Wikipedia [en.wikipedia.org]
- 20. [jocpr.com](https://www.jocpr.com) [[jocpr.com](https://www.jocpr.com)]
- To cite this document: BenchChem. [Structure-activity relationship of alkylated phenols]. BenchChem, [2026]. [Online PDF]. Available at: [<https://www.benchchem.com/product/b1222043/docs#structure-activity-relationship-of-alkylated-phenols>]

Disclaimer & Data Validity:

The information provided in this document is for Research Use Only (RUO) and is strictly not intended for diagnostic or therapeutic procedures. While BenchChem strives to provide

accurate protocols, we make no warranties, express or implied, regarding the fitness of this product for every specific experimental setup.

Technical Support: The protocols provided are for reference purposes. Unsure if this reagent suits your experiment?

Need Industrial/Bulk Grade? [Request Custom Synthesis Quote](#)

BenchChem

Our mission is to be the trusted global source of essential and advanced chemicals, empowering scientists and researchers to drive progress in science and industry.

Contact

Address: 3281 E Guasti Rd

Ontario, CA 91761, United States

Phone: (601) 213-4426

Email: info@benchchem.com

[Contact our Ph.D. Support Team for a compatibility check](#)