

Spectroscopic Characterization of 4-Chloro-3-nitro-1H-quinolin-2-one

Author: BenchChem Technical Support Team. **Date:** May 2026

Compound of Interest

Compound Name: 4-chloro-3-nitro-1H-quinolin-2-one

Cat. No.: B1222321

Get Quote

Technical Guide | Version 1.0

Executive Summary & Structural Context[2][3][4][5][6]

- Target Molecule: **4-Chloro-3-nitro-1H-quinolin-2-one**
- Molecular Formula:
[1]
- Exact Mass: 223.999[1]
- Key Functional Groups: Lactam (Amide), Nitro (), Aryl Chloride.[1]
- Role: High-value scaffold for displacements at the C-4 position.

Synthesis & Impurity Profile

To accurately interpret spectra, one must understand the synthesis pathway.[1] The target is typically generated via deoxygenative chlorination of 4-hydroxy-3-nitro-1H-quinolin-2-one using phosphorus oxychloride (

).

Critical Impurities to Monitor:

- Unreacted Precursor: 4-hydroxy-3-nitro-1H-quinolin-2-one (Broad OH stretch in IR, deshielded OH proton in NMR).
- Hydrolysis Product: Reversion to the hydroxy form due to moisture sensitivity of the C-Cl bond.[1]
- Regioisomers: Rare, but 2,4-dichloro-3-nitroquinoline can form if the lactam carbonyl is also chlorinated (usually requires

).

Synthesis Workflow & Characterization Logic

The following DOT diagram illustrates the synthesis logic and the critical spectroscopic checkpoints (CP) required to validate the transformation.

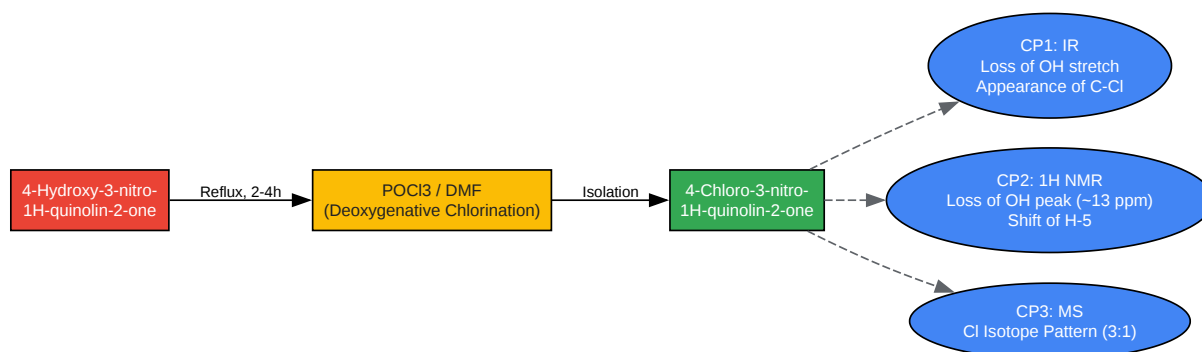

[Click to download full resolution via product page](#)

Caption: Synthesis workflow with integrated Spectroscopic Checkpoints (CP) for validation.

Nuclear Magnetic Resonance (NMR) Profiling

NMR is the primary tool for structural confirmation.[1] The substitution of the electron-donating Hydroxyl group (-OH) with the electron-withdrawing Chlorine (-Cl) at position 4 induces specific chemical shift changes.

Experimental Protocol: H and C NMR

- Solvent Selection: Dissolve 5-10 mg of sample in DMSO-

.
may be used but solubility is often poor for nitro-quinolones.

- Instrument: 400 MHz or higher recommended to resolve aromatic coupling.[1]
- Temperature: 298 K.

Data Interpretation Table

Nucleus	Signal	Chemical Shift (, ppm)	Multiplicity	Assignment	Mechanistic Insight
H	NH	12.5 - 13.0	Broad Singlet	H-1 (Lactam)	Exchangeable with .
H	H-5	8.20 - 8.35	Doublet (Hz)	Ar-H (Peri)	Deshielded by the adjacent Nitro group (C-3) and Cl (C-4). [1]
H	H-7	7.80 - 7.95	Triplet/Multiplet	Ar-H	Typical aromatic range.[1]
H	H-8	7.50 - 7.65	Doublet	Ar-H	Adjacent to Lactam Nitrogen.
H	H-6	7.40 - 7.55	Triplet/Multiplet	Ar-H	Typical aromatic range.[1]
C	C=O	~158.0	Quaternary	C-2	Lactam carbonyl.
C	C-Cl	~138.0 - 142.0	Quaternary	C-4	Upfield shift relative to C-OH precursor (~165 ppm) due to loss of resonance donation.[1]

C	C-NO2	~130.0 - 135.0	Quaternary	C-3	Strongly shielded by ortho-substituents. [1]
---	-------	-------------------	------------	-----	---

“

Critical Validation: The most significant indicator of successful reaction is the disappearance of the enolic OH proton which typically appears at

13.5–14.0 ppm in the precursor.[\[1\]](#) If this peak remains, the reaction is incomplete.
[\[1\]](#)

Infrared Spectroscopy (FT-IR)

FT-IR provides a rapid "fingerprint" assessment of functional group transformation.

Experimental Protocol

- Method: ATR (Attenuated Total Reflectance) or KBr Pellet.[\[1\]](#)
- Resolution: 4
- Scans: 16-32.

Diagnostic Bands[\[7\]](#)[\[8\]](#)[\[9\]](#)

- Absence of OH Stretch: The precursor displays a broad, intense band at 3200–3500
[\[1\]](#) The product should show no broad absorption here, only the sharper N-H stretch.[\[1\]](#)
- Lactam Carbonyl (C=O): Strong band at 1660–1690

.[\[1\]](#)

- Nitro Group (

): Two distinct bands.[\[1\]](#)

- Asymmetric stretch: 1520–1540

.[\[1\]](#)

- Symmetric stretch: 1340–1350

.[\[1\]](#)

- Aryl Chloride (C-Cl): Medium intensity band at 700–780

.[\[1\]](#)

Mass Spectrometry (MS)

Mass spectrometry confirms the molecular weight and the presence of chlorine via its unique isotopic signature.[\[1\]](#)

Fragmentation Pathway (EI/ESI)

The presence of the Nitro group and Chlorine directs the fragmentation.[\[1\]](#)

- Molecular Ion (

): m/z 224 (for

) and 226 (for

).[\[1\]](#)

- Base Peak: Often

or

.

Isotope Pattern Analysis

Chlorine has two stable isotopes:

(75.78%) and

(24.22%).^[1]

- Observation: You must observe an M and M+2 peak pattern with an intensity ratio of approximately 3:1.^[1]
- Significance: This confirms the substitution of OH (which has no M+2 isotope effect) with Cl.^[1]

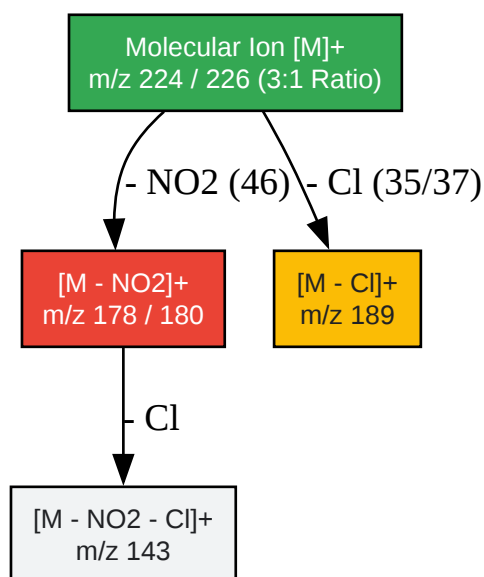

[Click to download full resolution via product page](#)

Caption: Predicted Mass Spectrometry fragmentation pathway for **4-chloro-3-nitro-1H-quinolin-2-one**.

X-Ray Crystallography (Optional but Definitive)

While not always routine, single-crystal X-ray diffraction (XRD) provides absolute structural proof, particularly for confirming the tautomeric state (Lactam vs. Lactim).^[1]

- Crystal Growth: Slow evaporation from Ethanol/DMF or Acetonitrile.^[1]

- Expected Space Group: Monoclinic () is common for planar quinolone derivatives.[1]
- Key Feature: Planar bicyclic system with the Nitro group potentially twisted out of plane due to steric hindrance with the C-4 Chlorine.[1]

References

- Cai, S. X., et al. (1996).[1] "Structure-Activity Relationships of 4-Hydroxy-3-nitroquinolin-2(1H)-ones as Novel Antagonists at the Glycine Site of N-Methyl-D-aspartate Receptors." Journal of Medicinal Chemistry.
- Abdou, M. M. (2017).[1] "Chemistry of 4-Hydroxy-2(1H)-quinolone. Part 1: Synthesis and reactions." Arabian Journal of Chemistry.
- Penjarla, T. R., et al. (2018).[1][2] "Synthesis of 4-Substituted Pyrrolo[2,3-c]quinolines via Microwave-Assisted C-N Bond Formation." ChemistrySelect. [1][2]
- Vaso, K., et al. (2010).[1] "Antibacterial Activity of Compounds Synthesized From 4-Chloro-3-nitro-2H-[1]-benzopyran-2-one." Asian Journal of Chemistry. [1]

Need Custom Synthesis?

BenchChem offers custom synthesis for rare earth carbides and specific isotopic labeling.

Email: info@benchchem.com or [Request Quote Online](#).

Sources

- 1. [researchgate.net](https://www.researchgate.net) [researchgate.net]
- 2. [scribd.com](https://www.scribd.com) [scribd.com]
- To cite this document: BenchChem. [Spectroscopic Characterization of 4-Chloro-3-nitro-1H-quinolin-2-one]. BenchChem, [2026]. [Online PDF]. Available at: [\[https://www.benchchem.com/product/b1222321/docs#spectroscopic-characterization-of-4-chloro-3-nitro-1h-quinolin-2-one\]](https://www.benchchem.com/product/b1222321/docs#spectroscopic-characterization-of-4-chloro-3-nitro-1h-quinolin-2-one)

Disclaimer & Data Validity:

The information provided in this document is for Research Use Only (RUO) and is strictly not intended for diagnostic or therapeutic procedures. While BenchChem strives to provide accurate protocols, we make no warranties, express or implied, regarding the fitness of this product for every specific experimental setup.

Technical Support: The protocols provided are for reference purposes. Unsure if this reagent suits your experiment?

Need Industrial/Bulk Grade? [Request Custom Synthesis Quote](#)

BenchChem

Our mission is to be the trusted global source of essential and advanced chemicals, empowering scientists and researchers to drive progress in science and industry.

Contact

Address: 3281 E Guasti Rd
Ontario, CA 91761, United States
Phone: (601) 213-4426
Email: info@benchchem.com

[Contact our Ph.D. Support Team for a compatibility check](#)