

Cross-Validation of Analytical Techniques for Dimethyl Telluride Quantification: A Comparative Guide

Author: BenchChem Technical Support Team. **Date:** April 2026

Compound of Interest

Compound Name: *Dimethyl telluride*

CAS No.: 593-80-6

Cat. No.: B1222758

[Get Quote](#)

For Researchers, Scientists, and Drug Development Professionals

This guide provides a comprehensive comparison of analytical techniques for the accurate quantification of **dimethyl telluride** (DMTe), a volatile organotellurium compound of interest in various research fields. The cross-validation of analytical methods is paramount to ensure data integrity, reproducibility, and comparability across different studies and laboratories. This document outlines the experimental protocols and performance characteristics of three key analytical techniques: Gas Chromatography-Mass Spectrometry (GC-MS), Gas Chromatography with Fluorine-Induced Chemiluminescence Detection (GC-FCD), and Gas Chromatography-Inductively Coupled Plasma-Mass Spectrometry (GC-ICP-MS).

Comparative Overview of Analytical Methods

The selection of an appropriate analytical method for **dimethyl telluride** quantification depends on factors such as the required sensitivity, selectivity, sample matrix complexity, and the specific research question. The following table summarizes the key performance characteristics of the compared techniques.

Performance Parameter	Gas Chromatography-Mass Spectrometry (GC-MS)	Gas Chromatography-Fluorine-Induced Chemiluminescence Detection (GC-FCD)	Gas Chromatography-Inductively Coupled Plasma-Mass Spectrometry (GC-ICP-MS)
Principle	Separation by GC followed by identification and quantification based on mass-to-charge ratio.	Separation by GC followed by detection of chemiluminescence from the reaction of tellurium compounds with fluorine.	Separation by GC followed by atomization and ionization in an inductively coupled plasma, with detection of tellurium isotopes by a mass spectrometer.
Linearity Range	Typically 2-3 orders of magnitude.	Wide linear detection range.[1]	Wide linear dynamic range.
Limit of Detection (LOD)	In the low ng/L to µg/L range for volatile organic compounds.	5-620 ng/L for volatile organochalcogens.[2]	As low as 0.07 ng/L for inorganic tellurium species (as a proxy for potential sensitivity).[3]
Limit of Quantification (LOQ)	Typically 3-5 times the LOD.	Not explicitly found for DMTe.	Not explicitly found for DMTe.
Accuracy (% Recovery)	Generally 80-120%.	95-105% for various organochalcogens in spiked samples.[2]	High accuracy expected due to elemental detection.
Precision (%RSD)	Typically <15%.	0.3-11.0% for various organochalcogens.[2]	<5% for inorganic tellurium species.[3]
Selectivity	High, based on mass fragmentation patterns.	Highly selective for sulfur, selenium, and tellurium compounds. [1]	Extremely high, based on isotopic mass of tellurium.

Experimental Protocols

Detailed methodologies are crucial for the replication and validation of analytical results. Below are representative protocols for each technique.

Gas Chromatography-Mass Spectrometry (GC-MS) with Headspace Sampling

This method is suitable for the analysis of volatile compounds like DMTe from liquid or solid matrices.

a. Sample Preparation (Headspace)

- Place a precisely weighed or measured amount of the sample (e.g., 1-5 g of solid or 1-5 mL of liquid) into a headspace vial (e.g., 20 mL).
- Seal the vial immediately with a PTFE-lined septum and aluminum cap.
- For quantitative analysis, an internal standard (e.g., deuterated DMTe, if available, or another suitable volatile organometallic compound) should be added to the sample prior to sealing.
- Incubate the vial in a headspace autosampler at a controlled temperature (e.g., 60-80°C) for a specific time (e.g., 15-30 minutes) to allow for the equilibration of DMTe between the sample and the headspace gas.

b. GC-MS Conditions

- Gas Chromatograph: Agilent 7890B or equivalent.
- Column: DB-5MS (30 m x 0.25 mm i.d., 0.25 μ m film thickness) or similar non-polar column.
- Injector: Split/splitless inlet, operated in splitless mode for trace analysis.
- Injector Temperature: 250°C.
- Carrier Gas: Helium at a constant flow rate (e.g., 1.0-1.5 mL/min).
- Oven Temperature Program:

- Initial temperature: 40°C, hold for 2 minutes.
- Ramp: 10°C/min to 200°C.
- Hold: 2 minutes at 200°C.
- Mass Spectrometer: Agilent 5977A or equivalent.
- Ionization Mode: Electron Ionization (EI) at 70 eV.
- Mass Range: m/z 35-350.
- Data Acquisition: Full scan for identification and Selected Ion Monitoring (SIM) for quantification, monitoring characteristic ions of DMTe (e.g., m/z 158, 143, corresponding to $[\text{CH}_3^{130}\text{TeCH}_3]^+$ and $[\text{TeCH}_3]^+$).

Gas Chromatography with Fluorine-Induced Chemiluminescence Detection (GC-FCD)

This technique offers high selectivity and sensitivity for tellurium-containing compounds.

a. Sample Preparation Sample preparation can be performed using headspace or purge and trap techniques as described for GC-MS.

b. GC-FCD Conditions

- Gas Chromatograph: Custom-built or commercial GC system.
- Column: Similar to GC-MS (e.g., DB-5MS).
- Injector: Split/splitless inlet.
- Carrier Gas: Helium or Nitrogen.
- Oven Temperature Program: Similar to GC-MS, optimized for the separation of volatile tellurium compounds.
- Detector: Fluorine-Induced Chemiluminescence Detector.

- Fluorine Flow: Optimized for maximum signal-to-noise ratio.
- Reaction Chamber Pressure: Maintained at a low pressure.
- Photomultiplier Tube (PMT): Positioned to detect the chemiluminescence emission.

Gas Chromatography-Inductively Coupled Plasma-Mass Spectrometry (GC-ICP-MS)

This powerful hyphenated technique provides exceptional sensitivity and elemental specificity for the quantification of DMTe.

a. Sample Preparation Headspace or purge and trap sampling is typically employed to introduce the volatile DMTe into the GC system.

b. GC-ICP-MS Conditions

- Gas Chromatograph: Agilent 7890B or equivalent.
- Column: As per GC-MS.
- Injector: Split/splitless inlet.
- Carrier Gas: Helium.
- Oven Temperature Program: As per GC-MS.
- Transfer Line: Heated transfer line connecting the GC outlet to the ICP-MS torch (e.g., 250-280°C).
- ICP-MS: Agilent 7900 or equivalent.
 - Plasma Conditions: Optimized for robust and stable plasma.
 - Monitored Isotopes: ^{125}Te , ^{128}Te , ^{130}Te .
 - Data Acquisition: Time-resolved analysis to obtain element-specific chromatograms.

Visualization of Workflows and Principles

To facilitate a clearer understanding of the analytical processes, the following diagrams illustrate the cross-validation workflow and the fundamental principles of the detection methods.

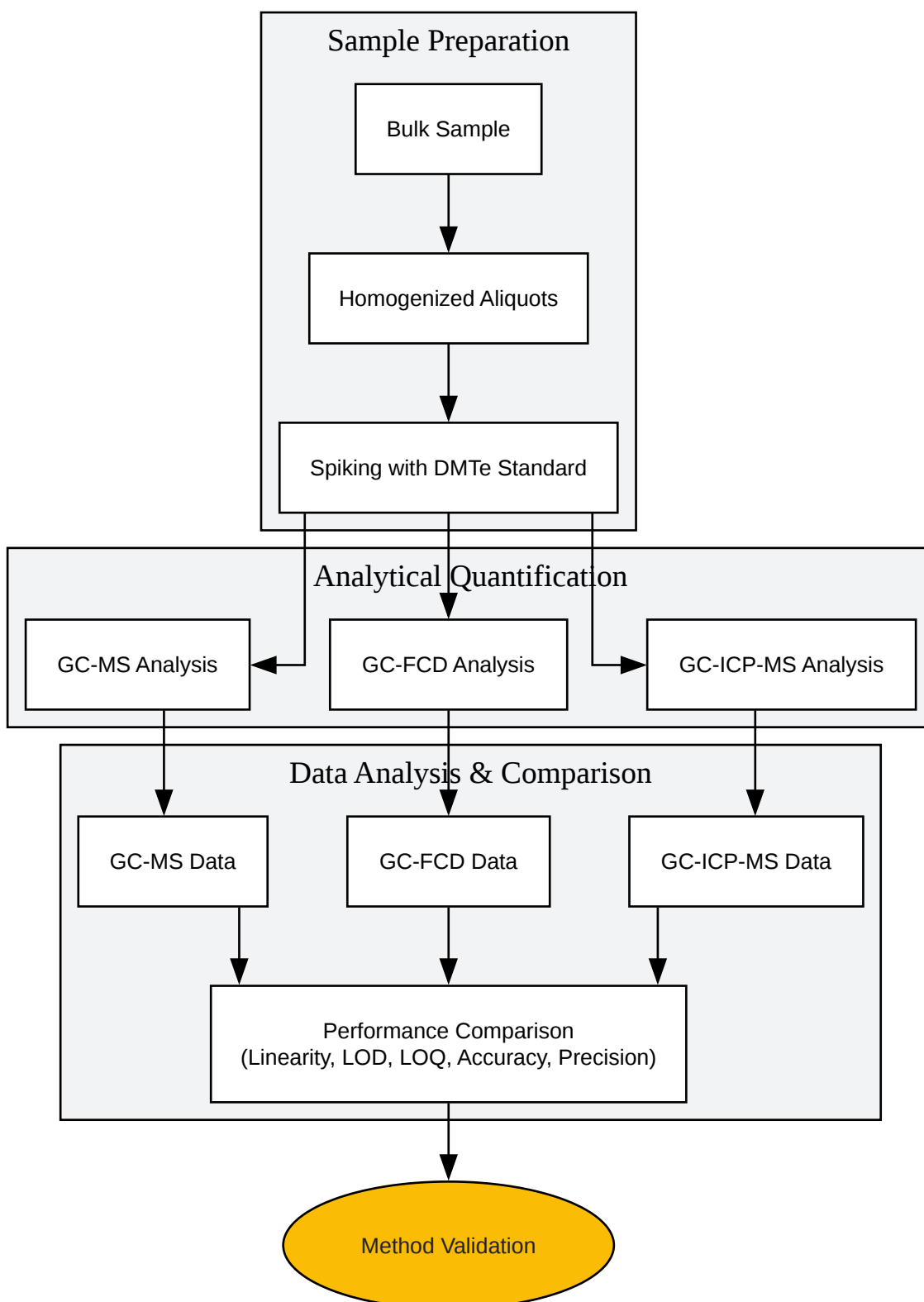

[Click to download full resolution via product page](#)

A simplified workflow for the cross-validation of analytical techniques for **dimethyl telluride** quantification.

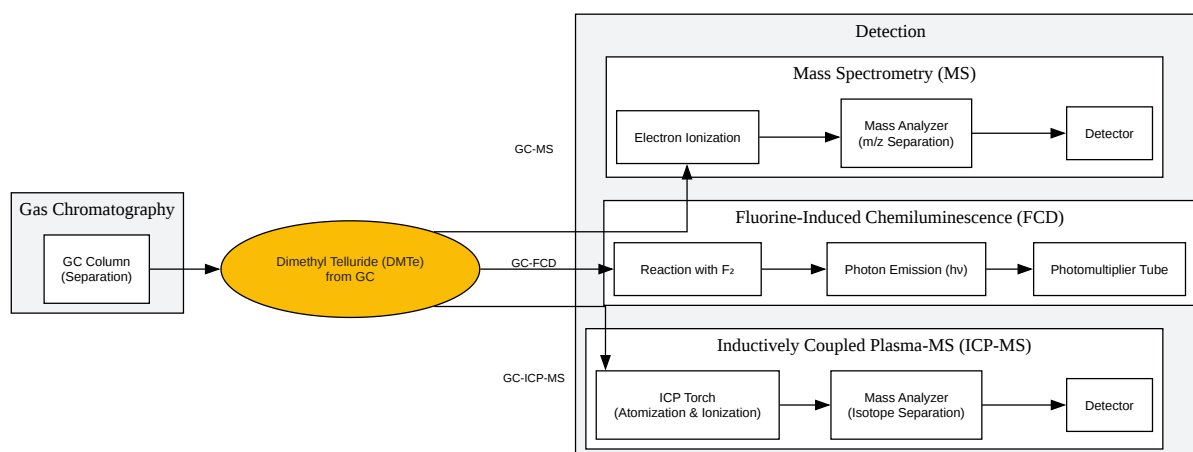

[Click to download full resolution via product page](#)

A diagram illustrating the fundamental principles of the three detection methods for **dimethyl telluride**.

Need Custom Synthesis?

BenchChem offers custom synthesis for rare earth carbides and specific isotopic labeling.

Email: info@benchchem.com or [Request Quote Online](#).

References

- 1. [benchchem.com](https://www.benchchem.com) [benchchem.com]

- [2. bibliotekanauki.pl \[bibliotekanauki.pl\]](#)
- [3. Non-chromatographic Speciation Analysis of Tellurium by HG-ICP-MS/MS at Sub ng L-1 Concentration in Natural Waters Using TIII as a Pre-Reducing Agent - PubMed \[pubmed.ncbi.nlm.nih.gov\]](#)
- To cite this document: BenchChem. [Cross-Validation of Analytical Techniques for Dimethyl Telluride Quantification: A Comparative Guide]. BenchChem, [2026]. [Online PDF]. Available at: [<https://www.benchchem.com/product/b1222758/docs#cross-validation-of-analytical-techniques-for-dimethyl-telluride-quantification-a-comparative-guide>]

Disclaimer & Data Validity:

The information provided in this document is for Research Use Only (RUO) and is strictly not intended for diagnostic or therapeutic procedures. While BenchChem strives to provide accurate protocols, we make no warranties, express or implied, regarding the fitness of this product for every specific experimental setup.

Technical Support: The protocols provided are for reference purposes. Unsure if this reagent suits your experiment?

Need Industrial/Bulk Grade? [Request Custom Synthesis Quote](#)

BenchChem

Our mission is to be the trusted global source of essential and advanced chemicals, empowering scientists and researchers to drive progress in science and industry.

Contact

Address: 3281 E Guasti Rd
Ontario, CA 91761, United States
Phone: (601) 213-4426
Email: info@benchchem.com

[Contact our Ph.D. Support Team for a compatibility check](#)

