

Application Note: Barium Tetracyanoplatinate in Fluoroscopy and X-Ray Detection

Author: BenchChem Technical Support Team. **Date:** April 2026

Compound of Interest

Compound Name: *Barium tetracyanoplatinate*

CAS No.: 562-81-2

Cat. No.: B1221347

[Get Quote](#)

Introduction & Historical Context

Barium tetracyanoplatinate(II) tetrahydrate (historically known as barium platinocyanide) holds a foundational place in modern physics and medical diagnostics. In 1895, Wilhelm Conrad Röntgen unwittingly performed the first X-Ray Excited Optical Luminescence (XEOL) experiment when he observed that invisible cathode rays caused a nearby cardboard screen painted with barium platinocyanide to emit a faint shimmering glow[1].

Today, while modern electronic detectors have largely replaced chemical phosphors, **barium tetracyanoplatinate** remains a critical reference material in materials science and synchrotron spectroscopy for understanding the fundamental mechanisms of X-ray to optical photon conversion[2]. This application note provides a comprehensive guide to the physicochemical properties, screen fabrication protocols, and XEOL characterization of this historic scintillator.

Mechanistic Principles: X-Ray Excited Optical Luminescence (XEOL)

The fluorescence of **barium tetracyanoplatinate** under X-ray irradiation is governed by a secondary radiative decay process known as XEOL[2]. When the material is bombarded with high-energy X-rays, the primary event is the absorption of photons by tightly bound core electrons (e.g., at the Barium M-edge or Platinum L-edge), leading to the ejection of photoelectrons[3].

This creates a core hole, triggering a cascade of Auger electrons and secondary electrons as the system relaxes. These electrons lose energy as they propagate through the solid lattice, eventually thermalizing to the band edge. The final step is the recombination of these thermalized charge carriers, which emits an optical photon. In the case of **barium tetracyanoplatinate**, this emission occurs at an energy of approximately 2 eV, yielding the characteristic orange-red light that Röntgen observed[2].

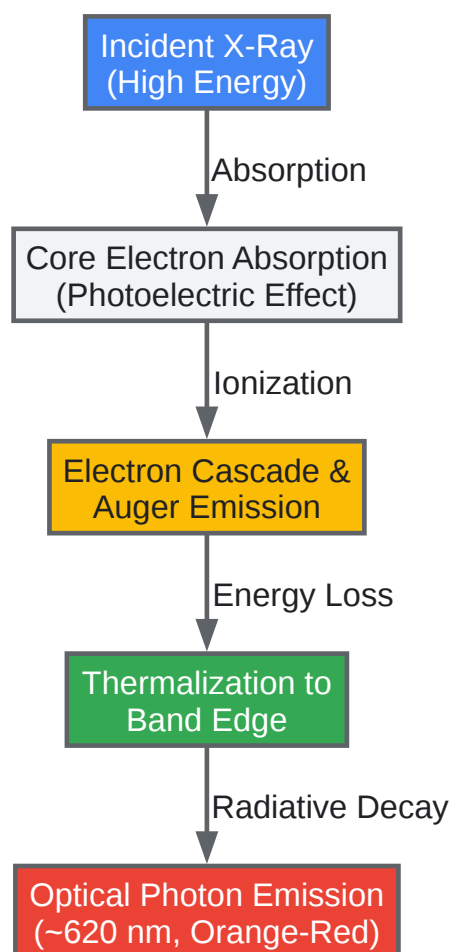

[Click to download full resolution via product page](#)

Mechanism of X-Ray Excited Optical Luminescence (XEOL) in **Barium Tetracyanoplatinate**.

Physicochemical & Optical Properties

To successfully utilize **barium tetracyanoplatinate** in fluoroscopy applications, strict adherence to its physical and chemical tolerances is required. The table below summarizes the critical quantitative parameters of the compound.

Parameter	Value	Reference
Chemical Formula	BaPt(CN) ₄ · 4H ₂ O	[4]
Molecular Weight	508.54 g/mol	
Density	3.05 g/cm ³	[4]
Physical Appearance	Large dichroic crystals / Yellow powder	
Optical Dichroism	Yellowish-green (transmitted), Bluish-violet (reflected)	
Peak Emission (XEOL)	~620 nm (Orange-Red, ~2 eV)	[2]
Aqueous Solubility	Soluble in ~35 parts H ₂ O (higher in hot H ₂ O)	

Experimental Protocols

Protocol A: Preparation and Purification of BaPt(CN)₄·4H₂O Crystals

Objective: To prepare high-purity, defect-free crystals suitable for X-ray scintillation.

- **Dissolution:** Dissolve approximately 4 g of commercial crude **barium tetracyanoplatinate** in 50 mL of deionized water[5].
- **Heating:** Warm the solution to 60 °C under continuous stirring until complete dissolution is achieved[5].
- **Filtration:** Filter the hot solution through a medium-grit glass filter to remove insoluble impurities.

- Crystallization: Allow the filtrate to cool slowly to room temperature in a dark environment to induce crystallization[5].
- Collection: Collect the resulting crystals via centrifugation and dry them under ambient conditions.
- Causality: High-purity crystals are mandatory because trace transition metal impurities act as non-radiative recombination centers, which severely quench the XEOL signal. Slow cooling ensures the formation of the stable tetrahydrate phase, which is the highly luminescent form[5].
- Self-Validation Check: Verify the hydration state and purity by observing the crystals under polarized light. Pure $\text{BaPt}(\text{CN})_4 \cdot 4\text{H}_2\text{O}$ exhibits strong dichroism, appearing yellowish-green under transmitted light and bluish-violet under reflected light.

Protocol B: Fabrication of the Fluoroscopy Screen

Objective: To create a homogeneous, highly responsive X-ray detection screen.

- Milling: Transfer the purified $\text{BaPt}(\text{CN})_4 \cdot 4\text{H}_2\text{O}$ crystals to an agate mortar. Grind the crystals very gently to a uniform powder.
- Binder Integration: Mix the powder with a radiotransparent binder (e.g., a dilute collodion or cellulose acetate solution) to form a viscous slurry.
- Coating: Apply the slurry evenly onto a radiolucent substrate, such as a thin sheet of black cardboard or a low-Z polymer film.
- Curing: Allow the screen to dry completely in a dark, ambient-temperature environment.
- Causality: The choice of binder is critical; it must be radiotransparent to prevent the attenuation of incident X-rays before they reach the active phosphor layer. Furthermore, grinding must be exceptionally gentle. Vigorous grinding induces mechanical strain in the crystal lattice and reduces grain size excessively, which impairs electron thermalization and shifts the peak emission wavelength, ultimately degrading luminescence[6].

- Self-Validation Check: Expose the dried screen to a calibrated UV source (e.g., 365 nm) prior to X-ray exposure. A uniform orange-red emission confirms the homogeneous distribution of the phosphor and the absence of binder-induced quenching[2].

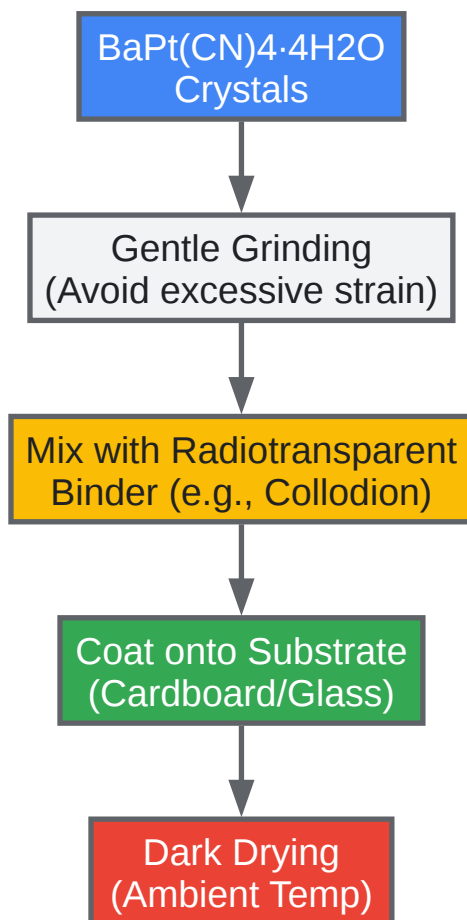

[Click to download full resolution via product page](#)

Workflow for preparing a **Barium Tetracyanoplatinate** fluoroscopy screen.

Protocol C: X-Ray Excited Optical Luminescence (XEOL) Assay

Objective: To characterize the optical response of the screen using modern synchrotron techniques.

- Mounting: Place the fabricated screen in the vacuum chamber of an X-ray spectrometer.

- Excitation: Irradiate the sample using tunable synchrotron X-rays, scanning energies from 10 to 150 eV above the chemical potential of the target element (e.g., the Pt L-edge)[3].
- Detection: Capture the emitted optical photons using an optical spectrometer coupled to a photomultiplier tube or avalanche photodiode.
- Analysis: Map the optical yield as a function of the incident X-ray energy to generate the XEOL spectrum.
- Causality: Utilizing tunable synchrotron X-rays allows researchers to selectively excite specific elements. This element specificity isolates the primary absorption event, allowing precise mapping of how core-hole relaxation and subsequent Auger electron cascades populate the optical emission states[3].
- Self-Validation Check: Monitor the X-ray Absorption Near Edge Structure (XANES) simultaneously with the optical yield. A direct correlation between the absorption edge jump and the optical emission intensity confirms that the luminescence is directly driven by the targeted element's photoelectric absorption[3].

References

- Revisiting the discovery of X-rays with modern spectroscopy: X-ray spectroscopic studies of barium platinocyanide: the scintillator that led to the discovery - Canadian Science Publishing. [2](#)
- X-ray spectroscopic studies of barium platinocyanide - Scholaris.ca. [6](#)
- Revisiting the discovery of X-rays with modern spectroscopy: X-ray spectroscopic studies of barium platinocyanide: the scintillator that led to the discovery | Request PDF - ResearchGate.[3](#)
- Mean Lifetime of an Embryo in the Homogeneous Nucleation from Solution of the Tetracyanoplatinates(II) of Barium, Calcium, and Magnesium - Canadian Science Publishing. [5](#)
- Compounds and Catalysts - Thermo Fisher Scientific. [4](#)

- Handbook of Inorganic compounds - National Academic Digital Library of Ethiopia.
- Wilhelm Conrad Röntgen and the Discovery of X-Rays - Spectroscopy Online.¹

Need Custom Synthesis?

BenchChem offers custom synthesis for rare earth carbides and specific isotopic labeling.

Email: info@benchchem.com or [Request Quote Online](#).

Sources

- [1. spectroscopyonline.com](https://spectroscopyonline.com) [spectroscopyonline.com]
- [2. cdnsiencepub.com](https://cdnsiencepub.com) [cdnsiencepub.com]
- [3. researchgate.net](https://researchgate.net) [researchgate.net]
- [4. documents.thermofisher.com](https://documents.thermofisher.com) [documents.thermofisher.com]
- [5. cdnsiencepub.com](https://cdnsiencepub.com) [cdnsiencepub.com]
- [6. utoronto.scholaris.ca](https://utoronto.scholaris.ca) [utoronto.scholaris.ca]
- To cite this document: BenchChem. [Application Note: Barium Tetracyanoplatinate in Fluoroscopy and X-Ray Detection]. BenchChem, [2026]. [Online PDF]. Available at: [<https://www.benchchem.com/product/b1221347/docs#application-note-barium-tetracyanoplatinate-in-fluoroscopy-and-x-ray-detection>]

Disclaimer & Data Validity:

The information provided in this document is for Research Use Only (RUO) and is strictly not intended for diagnostic or therapeutic procedures. While BenchChem strives to provide accurate protocols, we make no warranties, express or implied, regarding the fitness of this product for every specific experimental setup.

Technical Support: The protocols provided are for reference purposes. Unsure if this reagent suits your experiment?

Need Industrial/Bulk Grade? [Request Custom Synthesis Quote](#)

BenchChem

Our mission is to be the trusted global source of essential and advanced chemicals, empowering scientists and researchers to drive progress in science and industry.

Contact

Address: 3281 E Guasti Rd
Ontario, CA 91761, United States
Phone: (601) 213-4426
Email: info@benchchem.com

[Contact our Ph.D. Support Team for a compatibility check](#)