

# An In-depth Technical Guide to Nucleophilic Substitution Reactions Involving Cholesteryl Iodide

**Author:** BenchChem Technical Support Team. **Date:** May 2026

## Compound of Interest

Compound Name:	Cholesteryl iodide
CAS No.:	2930-80-5
Cat. No.:	B1221673

[Get Quote](#)

This guide provides a comprehensive overview of nucleophilic substitution reactions involving **cholesteryl iodide**, a key intermediate in the synthesis of various cholesterol derivatives.<sup>[1]</sup> It is intended for researchers, scientists, and drug development professionals seeking a deeper understanding of the mechanistic nuances and practical applications of these reactions.

## Introduction: The Significance of Cholesteryl Iodide in Steroid Chemistry

Cholesterol, an essential component of cell membranes, also serves as a precursor for the biosynthesis of steroid hormones, bile acids, and vitamin D.<sup>[2][3][4]</sup> The modification of the cholesterol backbone through synthetic chemistry has led to the development of a wide array of compounds with significant therapeutic and biological applications.<sup>[1]</sup> **Cholesteryl iodide** (3 $\beta$ -iodocholest-5-ene) is a pivotal intermediate in this field, offering a reactive handle for introducing diverse functional groups at the C-3 position via nucleophilic substitution.<sup>[1]</sup> The iodine atom, being an excellent leaving group, facilitates reactions with a variety of nucleophiles, enabling the synthesis of cholesteryl esters, ethers, and other derivatives.<sup>[1][5]</sup>

# Synthesis of Cholesteryl Iodide: A Necessary Prelude

The journey into the nucleophilic substitution reactions of **cholesteryl iodide** begins with its synthesis from cholesterol. Several methods have been established, each with its own advantages and mechanistic considerations.

## Common Synthetic Routes:

- **Direct Iodination:** This method involves the treatment of cholesterol with an iodinating agent like iodine monochloride. The reaction proceeds through the electrophilic attack of the iodinating agent on the hydroxyl group.[1]
- **From Cholesteryl Tosylate:** A two-step process where cholesterol is first converted to its p-toluenesulfonate (tosylate) ester. Subsequent treatment with sodium iodide in acetone leads to the displacement of the tosylate group.[6]
- **Via Cholesteryl Chloroformate:** A convenient method that utilizes the readily available cholesteryl chloroformate. Reaction with sodium iodide in acetone provides good yields of **cholesteryl iodide**. [6]
- **Using Trimethylsilyl Iodide (TMSI):** A modern and efficient method, particularly for generating glycosyl iodides that can then react with cholesterol. [7][8] This approach often utilizes microwave conditions to achieve high yields and stereoselectivity. [7][8]

The choice of synthetic method often depends on the desired scale, purity requirements, and available reagents.

## The Dichotomy of Nucleophilic Substitution: S<sub>n</sub>1 vs. S<sub>n</sub>2 Pathways

Nucleophilic substitution reactions at a saturated carbon atom, such as the C-3 of **cholesteryl iodide**, can proceed through two primary mechanisms: S<sub>n</sub>1 (substitution nucleophilic unimolecular) and S<sub>n</sub>2 (substitution nucleophilic bimolecular). [9][10][11] The operative pathway is dictated by several factors, including the structure of the substrate, the nature of the nucleophile, the solvent, and the leaving group. [12]

## The S<sub>n</sub>2 Mechanism: A Concerted Dance

The S<sub>n</sub>2 reaction is a single-step process where the nucleophile attacks the electrophilic carbon from the backside, simultaneously displacing the leaving group.<sup>[5][11][13]</sup> This "backside attack" leads to an inversion of stereochemistry at the reaction center, a phenomenon known as Walden inversion.<sup>[14][15]</sup>

The rate of an S<sub>n</sub>2 reaction is dependent on the concentrations of both the substrate and the nucleophile, making it a second-order reaction.<sup>[9][13][16]</sup>

$$\text{Rate} = k[\text{Substrate}][\text{Nucleophile}]^{\text{[13][16]}}$$

A critical factor governing S<sub>n</sub>2 reactions is steric hindrance.<sup>[14][17][18][19]</sup> Bulky groups around the reaction center impede the approach of the nucleophile, slowing down or even preventing the reaction.<sup>[14][17][18][19]</sup> **Cholesteryl iodide**, with its bulky steroid framework, presents significant steric hindrance at the C-3 position, making S<sub>n</sub>2 reactions challenging.<sup>[14][17][20]</sup>

## The S<sub>n</sub>1 Mechanism: A Stepwise Affair

In contrast, the S<sub>n</sub>1 reaction is a two-step process.<sup>[10][21]</sup> The first and rate-determining step involves the slow ionization of the substrate to form a carbocation intermediate.<sup>[16][21]</sup> The second step is the rapid attack of the nucleophile on the planar carbocation.<sup>[11][16]</sup>

$$\text{Rate} = k[\text{Substrate}]^{\text{[9][16]}}$$

The rate of an S<sub>n</sub>1 reaction is independent of the nucleophile's concentration.<sup>[9][16][22]</sup> The stability of the carbocation intermediate is paramount. Tertiary carbocations are the most stable, followed by secondary, and then primary.<sup>[9][16]</sup> The C-3 carbon of the cholesterol framework is a secondary carbon, and the resulting secondary carbocation can be stabilized by the surrounding alkyl groups.<sup>[17]</sup>

The planar nature of the carbocation allows the nucleophile to attack from either face, leading to a mixture of retention and inversion of stereochemistry, often resulting in racemization if the starting material is chiral.<sup>[11][15]</sup>

# Factors Influencing the Reaction Pathway of Cholesteryl Iodide

The competition between  $S_{n1}$  and  $S_{n2}$  pathways in reactions of **cholesteryl iodide** is a delicate balance influenced by several key experimental parameters.

## The Substrate: Steric Hindrance at the Forefront

As mentioned, the bulky steroid nucleus of **cholesteryl iodide** significantly disfavors the  $S_{n2}$  pathway due to steric hindrance.<sup>[14][17][20]</sup> This steric impediment makes the backside attack required for an  $S_{n2}$  reaction energetically unfavorable.<sup>[14][19]</sup> Consequently, reactions of **cholesteryl iodide** often lean towards an  $S_{n1}$  mechanism, proceeding through a carbocation intermediate.<sup>[17]</sup>

## The Nucleophile: Strength Matters

- **Strong Nucleophiles:** Strong, negatively charged nucleophiles (e.g.,  $RO^-$ ,  $CN^-$ ,  $RS^-$ ) generally favor  $S_{n2}$  reactions.<sup>[12][18]</sup> Their high reactivity allows them to attack the electrophilic carbon directly without waiting for carbocation formation.
- **Weak Nucleophiles:** Weak, neutral nucleophiles (e.g.,  $H_2O$ ,  $ROH$ ,  $RCOOH$ ) are less reactive and typically favor  $S_{n1}$  reactions.<sup>[12]</sup> They are not strong enough to initiate a backside attack and will wait for the formation of the more electrophilic carbocation.

## The Solvent: A Polarizing Decision

The choice of solvent plays a crucial role in determining the reaction mechanism.<sup>[23][24][25]</sup>

- **Polar Protic Solvents:** These solvents (e.g., water, alcohols) have hydrogen atoms bonded to electronegative atoms and are capable of hydrogen bonding.<sup>[23][24]</sup> They are excellent at stabilizing both the carbocation intermediate and the leaving group in  $S_{n1}$  reactions through solvation.<sup>[17][23][24][26]</sup> This stabilization lowers the activation energy for the ionization step, promoting the  $S_{n1}$  pathway.<sup>[23][24]</sup> Conversely, polar protic solvents can solvate and stabilize the nucleophile, reducing its reactivity and hindering  $S_{n2}$  reactions.<sup>[23][24]</sup>
- **Polar Aprotic Solvents:** These solvents (e.g., acetone, DMSO, DMF) have dipoles but lack acidic protons.<sup>[17][18]</sup> They can solvate cations but are less effective at solvating anions (the

nucleophile).[18] This leaves the nucleophile "naked" and more reactive, thus favoring  $S_N2$  reactions.[18][25]

## The Leaving Group: A Good Departure is Key

The iodide ion ( $I^-$ ) is an excellent leaving group because it is a very weak base and can stabilize the negative charge effectively.[5][27] A good leaving group is essential for both  $S_N1$  and  $S_N2$  reactions as it facilitates the breaking of the carbon-leaving group bond.[10][26]

## Potential Side Reactions: The Elimination Competition

Nucleophilic substitution reactions are often accompanied by elimination reactions ( $E1$  and  $E2$ ), where a proton is removed from an adjacent carbon, leading to the formation of a double bond.[28][29]

- $E2$  Reaction: A bimolecular, one-step process favored by strong, sterically hindered bases.
- $E1$  Reaction: A unimolecular, two-step process that proceeds through the same carbocation intermediate as the  $S_N1$  reaction.[28]

In the case of **cholesteryl iodide**, the presence of protons on the adjacent C-2 and C-4 carbons makes elimination a possibility. The choice of a strong, non-nucleophilic base and higher temperatures will favor elimination over substitution.

## Experimental Protocols: A Practical Approach

The following protocols are illustrative examples of nucleophilic substitution reactions on **cholesteryl iodide**.

### Synthesis of Cholesteryl Acetate (An $S_N1$ -type Reaction)

This reaction exemplifies a solvolysis reaction where the solvent (acetic acid) also acts as the nucleophile.[30]

Methodology:

- Dissolve **cholesteryl iodide** (1.0 g) in glacial acetic acid (20 mL).

- Add silver acetate (1.5 eq) to the solution. The silver ion assists in the removal of the iodide leaving group.
- Heat the reaction mixture at reflux for 4 hours.
- Monitor the reaction progress by Thin Layer Chromatography (TLC).
- After completion, cool the mixture and pour it into ice-water.
- Extract the product with diethyl ether.
- Wash the organic layer with saturated sodium bicarbonate solution and then with brine.
- Dry the organic layer over anhydrous sodium sulfate and concentrate under reduced pressure.
- Purify the crude product by recrystallization from ethanol to yield cholesteryl acetate.

## Synthesis of a Cholesteryl Ether (An S<sub>N</sub>2-type Reaction with a Strong Nucleophile)

This protocol uses a strong nucleophile (alkoxide) which can favor an S<sub>N</sub>2-like pathway, despite the steric hindrance.

Methodology:

- In a flame-dried flask under an inert atmosphere (e.g., argon), add sodium hydride (1.2 eq) to anhydrous tetrahydrofuran (THF).
- Cool the suspension to 0 °C and slowly add the desired alcohol (e.g., ethanol, 1.1 eq).
- Allow the mixture to stir at room temperature for 30 minutes to form the sodium alkoxide.
- Add a solution of **cholesteryl iodide** (1.0 eq) in anhydrous THF to the alkoxide solution.
- Heat the reaction mixture at reflux and monitor by TLC.
- Upon completion, carefully quench the reaction with water at 0 °C.

- Extract the product with diethyl ether.
- Wash the organic layer with water and brine.
- Dry the organic layer over anhydrous sodium sulfate and concentrate in vacuo.
- Purify the resulting cholesteryl ether by column chromatography on silica gel.

## Data Presentation: Understanding the Outcomes

The success of these reactions is typically evaluated by yield and purity, determined by techniques such as NMR spectroscopy, mass spectrometry, and melting point analysis.

Table 1: Comparison of Reaction Conditions and Outcomes

Reaction	Nucleophile	Solvent	Typical Mechanism	Expected Product
Acetylation	Acetic Acid	Acetic Acid	S <sub>n</sub> 1	Cholesteryl Acetate
Ether Synthesis	Alkoxide	THF	S <sub>n</sub> 2-favored	Cholesteryl Ether

## Visualization of Reaction Pathways

### S<sub>n</sub>1 and S<sub>n</sub>2 Mechanisms

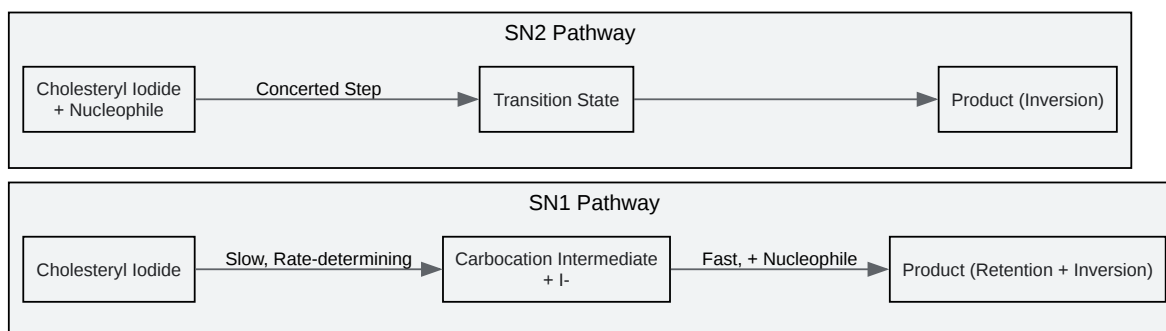

[Click to download full resolution via product page](#)

Caption: S<sub>n</sub>1 and S<sub>n</sub>2 reaction pathways for **cholesteryl iodide**.

## Experimental Workflow for Cholesteryl Derivative Synthesis

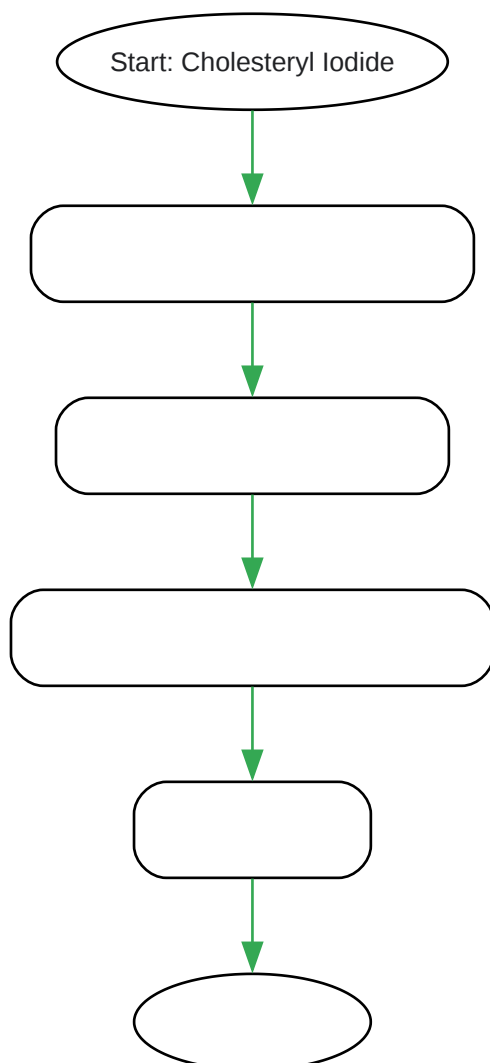

[Click to download full resolution via product page](#)

### Need Custom Synthesis?

BenchChem offers custom synthesis for rare earth carbides and specific isotopic labeling.

Email: [info@benchchem.com](mailto:info@benchchem.com) or [Request Quote Online](#).

## Sources

- [1. Buy Cholesteryl iodide | 2930-80-5 \[smolecule.com\]](#)
- [2. A Novel Synthesis Process of Cholesterol Ester by the Cross-Coupling of Cholesterol and Aroyl Chlorides - PubMed \[pubmed.ncbi.nlm.nih.gov\]](#)
- [3. A Novel Synthesis Process of Cholesterol Ester by the Cross-Coupling of Cholesterol and Aroyl Chlorides \[scirp.org\]](#)
- [4. gacariyalur.ac.in \[gacariyalur.ac.in\]](#)
- [5. rammohancollege.ac.in \[rammohancollege.ac.in\]](#)
- [6. pubs.acs.org \[pubs.acs.org\]](#)
- [7. Synthesis of cholesteryl- \$\alpha\$ -D-lactoside via generation and trapping of a stable  \$\beta\$ -lactosyl iodide - PMC \[pmc.ncbi.nlm.nih.gov\]](#)
- [8. Synthesis of cholesteryl- \$\alpha\$ -D-lactoside via generation and trapping of a stable  \$\beta\$ -lactosyl iodide - PubMed \[pubmed.ncbi.nlm.nih.gov\]](#)
- [9. masterorganicchemistry.com \[masterorganicchemistry.com\]](#)
- [10. chem.libretexts.org \[chem.libretexts.org\]](#)
- [11. Nucleophilic Substitution \(SN1, SN2\) \[organic-chemistry.org\]](#)
- [12. chem.uci.edu \[chem.uci.edu\]](#)
- [13. chem.libretexts.org \[chem.libretexts.org\]](#)
- [14. studylib.net \[studylib.net\]](#)
- [15. youtube.com \[youtube.com\]](#)
- [16. youtube.com \[youtube.com\]](#)
- [17. Steric Hindrance in SN2 and SN1 Reactions - Chemistry Steps \[chemistrysteps.com\]](#)
- [18. chem.libretexts.org \[chem.libretexts.org\]](#)
- [19. youtube.com \[youtube.com\]](#)
- [20. Steric, Quantum, and Electrostatic Effects on SN2 Reaction Barriers in Gas Phase - PMC \[pmc.ncbi.nlm.nih.gov\]](#)
- [21. chemguide.co.uk \[chemguide.co.uk\]](#)
- [22. masterorganicchemistry.com \[masterorganicchemistry.com\]](#)
- [23. chem.libretexts.org \[chem.libretexts.org\]](#)

- [24. aliphatic nucleophilic substitution \[employees.csbsju.edu\]](#)
- [25. users.wfu.edu \[users.wfu.edu\]](#)
- [26. chem.libretexts.org \[chem.libretexts.org\]](#)
- [27. byjus.com \[byjus.com\]](#)
- [28. Elimination reaction - Wikipedia \[en.wikipedia.org\]](#)
- [29. masterorganicchemistry.com \[masterorganicchemistry.com\]](#)
- [30. Solvolysis - Wikipedia \[en.wikipedia.org\]](#)
- To cite this document: BenchChem. [An In-depth Technical Guide to Nucleophilic Substitution Reactions Involving Cholesteryl Iodide]. BenchChem, [2026]. [Online PDF]. Available at: [<https://www.benchchem.com/product/b1221673/docs#an-in-depth-technical-guide-to-nucleophilic-substitution-reactions-involving-cholesteryl-iodide>]

---

#### Disclaimer & Data Validity:

The information provided in this document is for Research Use Only (RUO) and is strictly not intended for diagnostic or therapeutic procedures. While BenchChem strives to provide accurate protocols, we make no warranties, express or implied, regarding the fitness of this product for every specific experimental setup.

**Technical Support:** The protocols provided are for reference purposes. Unsure if this reagent suits your experiment?

**Need Industrial/Bulk Grade?** [Request Custom Synthesis Quote](#)

## BenchChem

Our mission is to be the trusted global source of essential and advanced chemicals, empowering scientists and researchers to drive progress in science and industry.

#### Contact

Address: 3281 E Guasti Rd

Ontario, CA 91761, United States

Phone: (601) 213-4426

Email: [info@benchchem.com](mailto:info@benchchem.com)

Contact our Ph.D. Support Team for a compatibility check