

Technical Application Note: High-Fidelity GC Analysis of 2,2-Dimethylthiazolidine

Author: BenchChem Technical Support Team. **Date:** May 2026

Compound of Interest

Compound Name:	2,2-Dimethyl thiazolidine hydrochloride
CAS No.:	822-44-6
Cat. No.:	B1220868

[Get Quote](#)

Executive Summary

2,2-Dimethylthiazolidine (DMT) is a critical heterocyclic intermediate used in the synthesis of pharmaceuticals (e.g., penicillamine derivatives), radioprotective agents, and as a protecting group for cysteamine. Its analysis presents unique chromatographic challenges due to its secondary amine basicity, thermal lability, and hydrolytic equilibrium.

Standard non-polar columns (e.g., 5% phenyl) often yield severe peak tailing and retention time shifts due to the interaction of the amine moiety with active silanol sites. Furthermore, DMT exists in a dynamic equilibrium with its precursors (cysteamine and acetone), making sample preparation conditions critical to prevent on-column degradation.

This guide provides two validated protocols:

- Method A (Direct Injection): A purity assay using base-deactivated stationary phases.
- Method B (Derivatization): A trace-level method using N-acylation to stabilize the thiazolidine ring.

Chemical Context & Challenges[1][2][3]

The Equilibrium Challenge

DMT is a condensation product of cysteamine and acetone. In the presence of water or Lewis acids, the ring can open, reverting to the starting materials. This reaction is reversible and sensitive to pH and moisture.

- Implication: GC samples must be strictly anhydrous. Aqueous diluents will cause "split peaks" or high acetone backgrounds due to on-column hydrolysis.

Basicity and Tailing

The secondary amine in the thiazolidine ring (

) acts as a Lewis base.

- Implication: On standard silica columns, the amine adsorbs to acidic silanols, causing tailing. This necessitates the use of Base-Deactivated (Amine) columns or derivatization.

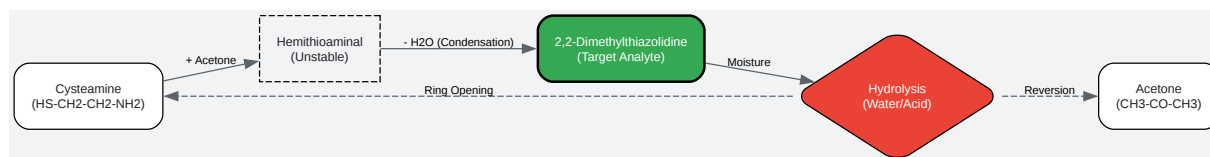

[Click to download full resolution via product page](#)

Figure 1: The formation and potential hydrolytic degradation pathway of 2,2-Dimethylthiazolidine.

Method A: Direct Injection (Purity Assay)

Objective: QC analysis of raw material purity (>98%). Strategy: Use a base-deactivated stationary phase to allow symmetrical peak elution without derivatization.

Instrument Configuration

Parameter	Specification	Rationale
GC System	Agilent 8890 or equivalent	High retention time precision required.
Inlet	Split/Splitless (S/SL)	
Liner	Base-Deactivated Split Liner with Wool	Standard wool strips amines; base-deactivation prevents adsorption.
Column	Rtx-5 Amine or CP-Volamine (30 m x 0.32 mm x 1.0 μ m)	Specific base-deactivation technology neutralizes surface silanols.
Detector	FID (280°C)	Universal response for carbon-containing heterocycles.
Carrier Gas	Helium or Hydrogen (Constant Flow: 1.5 mL/min)	Optimal linear velocity for resolution.

Temperature Program

- Initial: 50°C (Hold 2 min) — Traps volatile acetone impurities.
- Ramp 1: 15°C/min to 220°C.
- Final: 220°C (Hold 5 min) — Elutes heavier disulfide dimers.

Sample Preparation (Critical)

- Solvent: Use Anhydrous Dichloromethane (DCM) or Toluene. Avoid Methanol (protic solvents can promote ring opening).
- Concentration: Prepare 1 mg/mL solution.
- Drying: Add a single granule of Molecular Sieve (3Å) to the vial to scavenge trace moisture.
- Injection: 1.0 μ L, Split Ratio 50:1.

Method B: Derivatization (Trace Analysis)

Objective: Quantifying DMT in biological matrices or stability samples where peak shape is critical at low concentrations (<10 ppm). Strategy: Acetylation of the secondary amine blocks hydrogen bonding sites, improving volatility and stability.

Derivatization Protocol (In-Situ)

- Aliquot: Transfer 100 μ L of sample (in anhydrous aprotic solvent) to a GC vial.
- Reagent: Add 50 μ L Acetic Anhydride and 50 μ L Pyridine (catalyst/base).
- Incubation: Cap and heat at 60°C for 30 minutes.
- Quench: Evaporate to dryness under Nitrogen; reconstitute in Ethyl Acetate.
 - Note: This forms N-acetyl-2,2-dimethylthiazolidine.

Instrument Configuration (Method B)

- Column: DB-5ms UI (30 m x 0.25 mm x 0.25 μ m).
 - Why? The acetylated derivative is less polar and runs perfectly on standard phases.
- Inlet Temp: 250°C.
- Detector: MS (SIM mode) for high specificity.
 - Target Ions: m/z 159 (Molecular Ion), m/z 144 (M-15, loss of methyl).

Analytical Workflow Diagram

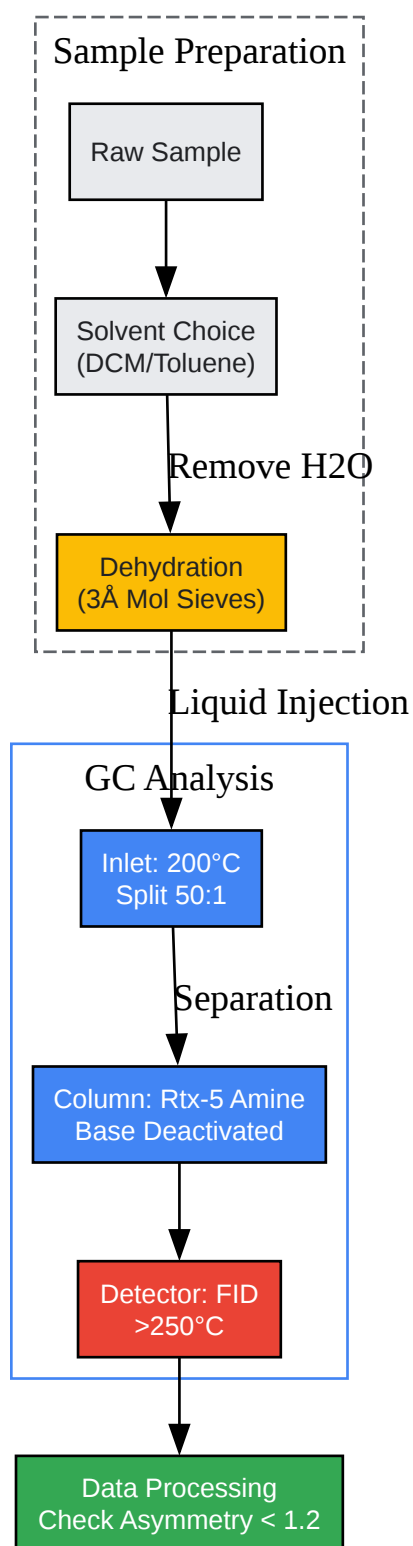

[Click to download full resolution via product page](#)

Figure 2: Step-by-step analytical workflow for Method A (Direct Injection).

Validation & Troubleshooting

System Suitability Criteria

To ensure the method is "self-validating" (Trustworthiness), every sequence must pass these checks:

Parameter	Acceptance Limit	Failure Cause
Tailing Factor (As)	< 1.3	Column activity. Replace liner or trim column.
Resolution (Rs)	> 2.0 (DMT vs. Acetone)	Temperature ramp too fast; start temp too high.
Recovery	98.0% - 102.0%	Volatility loss. Check vial seals.

Troubleshooting Guide

- Split Peaks: Indicates on-column hydrolysis.
 - Fix: Ensure the carrier gas trap is functioning (moisture removal) and the sample solvent is anhydrous.
- Ghost Peaks:
 - Cause: Oxidation of cysteamine to cystamine (disulfide) in the injector.
 - Fix: Lower inlet temperature to 200°C; use glass wool-free liners.
- Response Drift:
 - Cause: Amine adsorption on the FID jet.
 - Fix: Clean FID jet; ensure H₂/Air ratio is optimized (typically 1:10).

References

- National Center for Biotechnology Information (2026). PubChem Compound Summary for CID 88015, 2,2-Dimethylthiazolidine. Retrieved February 19, 2026 from [\[Link\]](#)

- Restek Corporation. Analysis of Volatile Amines on Rtx-Volatile Amine Columns. Application Note. Retrieved from [\[Link\]](#)
- Agilent Technologies. Gas Chromatographic Analysis of Amines using CP-Volamine. Retrieved from [\[Link\]](#)
- Little, J. L. (1999). Artifacts in Trimethylsilyl Derivatization Reactions and Ways to Avoid Them. Journal of Chromatography A, 844(1-2), 1-22.
- To cite this document: BenchChem. [Technical Application Note: High-Fidelity GC Analysis of 2,2-Dimethylthiazolidine]. BenchChem, [2026]. [Online PDF]. Available at: [\[https://www.benchchem.com/product/b1220868/docs#technical-application-note-high-fidelity-gc-analysis-of-2-2-dimethylthiazolidine\]](https://www.benchchem.com/product/b1220868/docs#technical-application-note-high-fidelity-gc-analysis-of-2-2-dimethylthiazolidine)

Disclaimer & Data Validity:

The information provided in this document is for Research Use Only (RUO) and is strictly not intended for diagnostic or therapeutic procedures. While BenchChem strives to provide accurate protocols, we make no warranties, express or implied, regarding the fitness of this product for every specific experimental setup.

Technical Support: The protocols provided are for reference purposes. Unsure if this reagent suits your experiment?

Need Industrial/Bulk Grade? [Request Custom Synthesis Quote](#)

BenchChem

Our mission is to be the trusted global source of essential and advanced chemicals, empowering scientists and researchers to drive progress in science and industry.

Contact

Address: 3281 E Guasti Rd
Ontario, CA 91761, United States
Phone: (601) 213-4426
Email: info@benchchem.com

Contact our Ph.D. Support Team for a compatibility check