

Determining Optimal Alagebrium Dosage for Cell Culture: Application Notes and Protocols

Author: BenchChem Technical Support Team. **Date:** April 2026

Compound of Interest

Compound Name:	Alagebrium
CAS No.:	393121-34-1
Cat. No.:	B1220623

[Get Quote](#)

For Researchers, Scientists, and Drug Development Professionals

These application notes provide a comprehensive guide for determining the optimal dosage of **Alagebrium** (ALT-711) for various cell culture applications. **Alagebrium** is a well-documented breaker of advanced glycation end-product (AGE) cross-links, making it a valuable tool for studying the roles of AGEs in cellular dysfunction, aging, and diabetes-related complications.^[1]^[2]

Mechanism of Action

Alagebrium's primary mechanism of action is the chemical cleavage of α -dicarbonyl-based covalent cross-links that form between proteins as a result of non-enzymatic glycation.^[3]^[4] These AGE cross-links contribute to tissue stiffening and loss of protein function.^[5]^[6] By breaking these pre-formed cross-links, **Alagebrium** can help restore protein and tissue function.^[2]^[4] Additionally, some studies suggest that **Alagebrium** may inhibit the formation of new AGEs by scavenging methylglyoxal, a reactive dicarbonyl species.^[2]^[3]^[7]

The accumulation of AGEs can activate cell surface receptors, most notably the Receptor for Advanced Glycation End-products (RAGE), initiating downstream signaling cascades that lead to oxidative stress and inflammation.[2][3] By reducing the overall AGE load, **Alagebrium** can attenuate this AGE-RAGE signaling.[2][3]

Quantitative Data Summary

The effective concentration of **Alagebrium** can vary depending on the cell type, the specific experimental conditions, and the endpoint being measured. The following tables summarize quantitative data from various studies to provide a starting point for dose-response experiments.

Table 1: Recommended Concentration Ranges of **Alagebrium** for In Vitro Studies

Parameter	Concentration Range	Cell Type/Context	Reference
General Working Concentration	1 μ M - 100 μ M	Various cell lines	[1][4][8]
Signaling Studies	1 μ M - 10 μ M	Cardiomyocytes	[9]
High-AGE Environments	Up to 1 mM	Collagen hydrogels	[1]

Table 2: Effects of **Alagebrium** on Cellular Proliferation and Signaling

Cell Type	AGE Treatment	Alagebrium Concentration	Observed Effect	Reference
Rat Aortic Vascular Smooth Muscle Cells (RASMCs)	50 µg/mL AGEs	1 µM - 100 µM	Dose-dependent inhibition of AGE-induced cell proliferation.	[8]
RASMCs	50 µg/mL AGEs	1 µM and 10 µM	Inhibition of ERK phosphorylation by 35% and 42%, respectively.	[8]

Experimental Protocols

Protocol 1: Preparation of Alagebrium Chloride Stock Solution

This protocol details the preparation of a 10 mM stock solution of **Alagebrium** Chloride, which can be further diluted to the desired working concentrations.

Materials:

- **Alagebrium** Chloride powder
- Sterile, anhydrous Dimethyl Sulfoxide (DMSO)
- Sterile microcentrifuge tubes or cryovials
- Calibrated analytical balance
- Sterile pipette tips
- Vortex mixer
- Personal Protective Equipment (PPE): lab coat, gloves, safety glasses

Procedure:

- Perform all steps in a sterile environment (e.g., a laminar flow hood).
- Tare a sterile microcentrifuge tube on an analytical balance.
- Carefully weigh 2.68 mg of **Alagebrium** Chloride powder into the tube.
- Using a calibrated pipette, add 1.0 mL of sterile, anhydrous DMSO to the tube.
- Securely close the tube and vortex for 1-2 minutes until the powder is completely dissolved. Gentle warming or sonication can be used to aid dissolution if precipitation is observed.[9]
- Aliquot the 10 mM stock solution into smaller, single-use volumes (e.g., 20-50 μ L) in sterile cryovials. This prevents contamination and degradation from repeated freeze-thaw cycles.[9]
- Clearly label the aliquots with the compound name, concentration, and date of preparation.
- Store the aliquots at -20°C for up to one year or at -80°C for up to two years.[4]

Protocol 2: Determining Optimal Alagebrium Concentration using a Cell Viability Assay (MTT Assay)

This protocol outlines a method to determine the optimal, non-toxic working concentration of **Alagebrium** for a specific cell line using a 3-(4,5-Dimethylthiazol-2-yl)-2,5-diphenyltetrazolium bromide (MTT) assay.

Materials:

- Target cells (e.g., fibroblasts, endothelial cells)
- Complete cell culture medium
- 96-well cell culture plates
- **Alagebrium** Chloride stock solution (10 mM in DMSO)
- MTT solution (5 mg/mL in PBS)

- Solubilization buffer (e.g., DMSO or acidified isopropanol)
- Phosphate-Buffered Saline (PBS)

Procedure:

- Cell Seeding: Seed cells into a 96-well plate at a density of 1×10^4 cells per well in 100 μL of complete medium and incubate for 24 hours to allow for cell attachment.[1][4]
- Preparation of **Alagebrium** Dilutions:
 - Prepare a series of working concentrations of **Alagebrium** (e.g., 0.1, 1, 5, 10, 25, 50, 100 μM) by serially diluting the 10 mM stock solution in complete culture medium.[1]
 - Prepare a vehicle control containing the same concentration of DMSO as the highest **Alagebrium** concentration.
 - Prepare a no-treatment control containing only culture medium.
- Cell Treatment:
 - After 24 hours of incubation, carefully remove the medium from the wells.
 - Add 100 μL of the prepared **Alagebrium** dilutions and controls to the respective wells (in triplicate).[1]
 - Incubate the plate for the desired experimental duration (e.g., 24, 48, or 72 hours).[1]
- MTT Assay:
 - After the incubation period, add 10 μL of MTT reagent (5 mg/mL in PBS) to each well.[1]
 - Incubate the plate for 3-4 hours at 37°C to allow viable cells to convert MTT to formazan crystals.[1]
 - Carefully remove the medium containing MTT.

- Add 100 μ L of a solubilization solution (e.g., DMSO) to each well to dissolve the formazan crystals.[1]
- Gently shake the plate for 5-10 minutes to ensure complete dissolution.[1]
- Data Analysis:
 - Measure the absorbance at 570 nm using a microplate reader.
 - Calculate the percentage of cell viability for each concentration relative to the vehicle control.
 - Plot the cell viability against the log of the **Alagebrium** concentration to generate a dose-response curve and determine the IC50 value (the concentration that inhibits 50% of cell viability).[1]

Note on Potential Assay Interference: As a thiazolium salt, **Alagebrium** may directly reduce MTT, leading to a false-positive signal. It is recommended to include a "no-cell" control with media and **Alagebrium** to check for direct MTT reduction. If interference is observed, consider an alternative viability assay such as the Sulforhodamine B (SRB) assay.[1]

Protocol 3: AGE-Induced Cell Proliferation Assay

This protocol is adapted from studies on rat aortic vascular smooth muscle cells (RASMCs) and can be modified for other adherent cell types to assess the inhibitory effect of **Alagebrium** on AGE-induced cell proliferation.[8][9]

Materials:

- RASMCs or other target cells
- Complete cell culture medium
- 96-well cell culture plates
- **Alagebrium** Chloride stock solution (10 mM in DMSO)
- Advanced Glycation End-products (e.g., AGE-BSA at a final concentration of 50 μ g/mL)

- MTT solution
- Solubilization buffer

Procedure:

- Cell Seeding: Seed RASMCs in a 96-well plate at a density of 1×10^4 cells per well and allow them to adhere.[4]
- Pre-treatment with **Alagebrium**: Prepare working solutions of **Alagebrium** in culture medium. Pre-treat the cells with various concentrations of **Alagebrium** (e.g., 1, 10, 50, 100 μ M) for 3 to 24 hours prior to adding the AGE stimulus.[4][8]
- AGE Stimulation: Add AGE-BSA to the wells to a final concentration of 50 μ g/mL.[9] Include control wells with **Alagebrium** alone and AGEs alone.
- Incubation: Incubate the plate for the desired period (e.g., 24-72 hours).
- MTT Assay and Data Analysis: Follow steps 4 and 5 from Protocol 2 to assess cell proliferation. Analyze the data to determine the inhibitory effect of **Alagebrium** on AGE-induced cell proliferation.

Visualizations

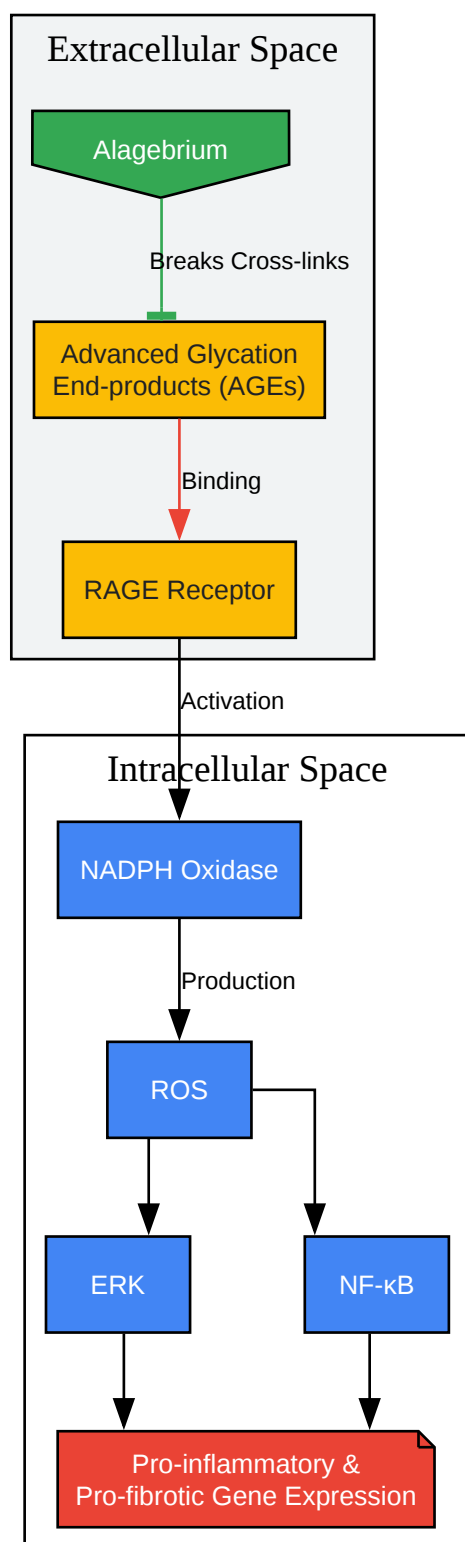

[Click to download full resolution via product page](#)

Caption: AGE-RAGE signaling pathway and the point of intervention by **Alagebrium**.

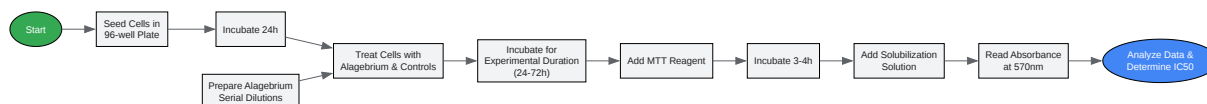

[Click to download full resolution via product page](#)

Caption: Workflow for determining the optimal concentration of **Alagebrium**.

Need Custom Synthesis?

BenchChem offers custom synthesis for rare earth carbides and specific isotopic labeling.

Email: info@benchchem.com or [Request Quote Online](#).

References

- 1. [benchchem.com](https://www.benchchem.com) [benchchem.com]
- 2. Alagebrium and Complications of Diabetes Mellitus - PMC [pmc.ncbi.nlm.nih.gov]
- 3. [benchchem.com](https://www.benchchem.com) [benchchem.com]
- 4. [benchchem.com](https://www.benchchem.com) [benchchem.com]
- 5. AGE-breaker ALT711 reverses glycation-mediated cancer cell migration - PubMed [pubmed.ncbi.nlm.nih.gov]
- 6. Glycation and Crosslinking of Extra-Cellular Proteins - Legendary Pharmaceuticals [legendarypharma.com]
- 7. Alagebrium attenuates acute methylglyoxal-induced glucose intolerance in Sprague-Dawley rats - PMC [pmc.ncbi.nlm.nih.gov]
- 8. Alagebrium Chloride, a Novel Advanced Glycation End-Product Cross Linkage Breaker, Inhibits Neointimal Proliferation in a Diabetic Rat Carotid Balloon Injury Model - PMC [pmc.ncbi.nlm.nih.gov]
- 9. [benchchem.com](https://www.benchchem.com) [benchchem.com]
- To cite this document: BenchChem. [Determining Optimal Alagebrium Dosage for Cell Culture: Application Notes and Protocols]. BenchChem, [2026]. [Online PDF]. Available at:

[<https://www.benchchem.com/product/b1220623/docs#determining-optimal-alagebrium-dosage-for-cell-culture-application-notes-and-protocols>]

Disclaimer & Data Validity:

The information provided in this document is for Research Use Only (RUO) and is strictly not intended for diagnostic or therapeutic procedures. While BenchChem strives to provide accurate protocols, we make no warranties, express or implied, regarding the fitness of this product for every specific experimental setup.

Technical Support: The protocols provided are for reference purposes. Unsure if this reagent suits your experiment?

Need Industrial/Bulk Grade? [Request Custom Synthesis Quote](#)

BenchChem

Our mission is to be the trusted global source of essential and advanced chemicals, empowering scientists and researchers to drive progress in science and industry.

Contact

Address: 3281 E Guasti Rd
Ontario, CA 91761, United States
Phone: (601) 213-4426
Email: info@benchchem.com

[Contact our Ph.D. Support Team for a compatibility check](#)