

Alagebrium (ALT-711) Development: A Technical Support Analysis of its Discontinuation

Author: BenchChem Technical Support Team. **Date:** April 2026

Compound of Interest

Compound Name: *Alagebrium*
CAS No.: *393121-34-1*
Cat. No.: *B1220623*

[Get Quote](#)

Technical Support Center – **Alagebrium** (ALT-711) Experimental Data

This technical support center provides researchers, scientists, and drug development professionals with a comprehensive overview of the development and subsequent discontinuation of **Alagebrium** (ALT-711), a once-promising agent targeting advanced glycation end-products (AGEs).

Frequently Asked Questions (FAQs)

Q1: What was the primary reason for the discontinuation of **Alagebrium** (ALT-711) development?

The development of **Alagebrium** was halted due to a combination of two primary factors:

- **Insufficient Clinical Efficacy:** In pivotal clinical trials, particularly in patients with heart failure, **Alagebrium** failed to meet its primary endpoints. For instance, the BENEFICIAL trial, a randomized, double-blind, placebo-controlled study, found no significant improvement in exercise tolerance (peak VO₂) in patients with systolic heart failure treated with **Alagebrium** compared to placebo.[1][2] While some smaller, open-label studies had shown promise in

improving certain cardiovascular parameters, these findings were not consistently replicated in larger, more robust trials.[3][4][5]

- **Financial Constraints:** Synvista Therapeutics Inc. (formerly Alteon Inc.), the company developing **Alagebrium**, faced significant financial difficulties. In early 2009, the company announced the termination of all ongoing clinical trials of **Alagebrium**, citing a review of its clinical development portfolio and its financial status.[1]

Q2: What was the proposed mechanism of action for **Alagebrium**?

Alagebrium was designed as an "AGE breaker." Its primary mechanism of action was the chemical cleavage of pre-formed α -dicarbonyl-based cross-links between proteins, which are a hallmark of advanced glycation end-products.[6] These AGEs contribute to the stiffening of tissues, particularly in the cardiovascular system, and are implicated in the pathophysiology of aging and diabetic complications. By breaking these cross-links, **Alagebrium** was expected to restore the elasticity and function of tissues.

Furthermore, **Alagebrium** was found to modulate the downstream signaling pathways initiated by the interaction of AGEs with their cellular receptor, the Receptor for Advanced Glycation End-products (RAGE). This interaction is known to trigger inflammatory and oxidative stress responses.

Q3: Were there any safety concerns with **Alagebrium**?

Based on the available clinical trial data, **Alagebrium** was generally well-tolerated.[1][4] The most commonly reported adverse events were gastrointestinal symptoms.[4] However, the discontinuation of its development was not primarily driven by safety issues but rather by the lack of demonstrated efficacy and financial challenges.

Troubleshooting Experimental Discrepancies

For researchers investigating AGE breakers, understanding the nuances of **Alagebrium**'s clinical trial outcomes is crucial. Here are some potential reasons for discrepancies between preclinical and clinical results:

- **Species-Specific Differences in AGEs:** Preclinical studies in animal models, particularly rodents, showed promising results with **Alagebrium**. However, it has been suggested that

the types of AGE cross-links prevalent in these animal models may differ from those most abundant in humans. Specifically, **Alagebrium** is not effective against glucosepane, the most common AGE cross-link found in human tissues. This fundamental difference could explain the lack of translation from preclinical success to clinical efficacy.

- **Patient Population and Disease Severity:** The patient populations enrolled in the clinical trials for **Alagebrium** had established cardiovascular disease. It is possible that the therapeutic window for an AGE breaker is earlier in the disease process before irreversible tissue damage has occurred. The stage and severity of the disease at the time of intervention could significantly impact the observed outcomes.
- **Dosage and Treatment Duration:** While various dosages and treatment durations were explored, it is possible that the optimal therapeutic regimen for achieving significant clinical benefit in humans was not identified within the conducted trials. For instance, an open-label study by Little et al. used a higher daily dose (420 mg) and showed some positive effects, whereas the larger BENEFICIAL trial used a 400 mg daily dose (200 mg twice daily) and failed to meet its primary endpoint.[\[3\]](#)[\[7\]](#)

Quantitative Data from Key Clinical Trials

The following tables summarize the quantitative data from two key clinical trials investigating the efficacy of **Alagebrium** in patients with heart failure.

Table 1: Open-Label Study in Diastolic Heart Failure (Little et al., 2005)[\[3\]](#)

Parameter	Baseline (Mean ± SD)	16-Week Follow-up (Mean ± SD)	P-value
Primary and Secondary Endpoints			
Left Ventricular Mass (g)	124 ± 35	119 ± 34	.036
E/E' Ratio	10.6 ± 2.7	9.4 ± 1.9	.076
E' (cm/s)	7.3 ± 1.2	8.4 ± 1.7	.045
Minnesota Living with Heart Failure Score	41 ± 21	32 ± 21	.01
Peak Exercise Oxygen Consumption (ml/kg/min)	13.1 ± 3.3	No significant change	NS
Aortic Distensibility	Not reported	No significant change	NS
Blood Pressure	Not reported	No significant change	NS

Table 2: BENEFICIAL Randomized Controlled Trial in Systolic Heart Failure (Hartog et al., 2011)[2]

Parameter	Alagebrium Group (Change from Baseline; Mean \pm SEM)	Placebo Group (Change from Baseline; Mean \pm SEM)	P-value
Primary Endpoint			
Peak VO ₂ (mL/min/kg)	-2.1 \pm 0.5	-0.5 \pm 0.7	.06
Secondary Endpoints			
Diastolic Function (E')	No significant change	No significant change	.32
Diastolic Function (E/E')	No significant change	No significant change	.81
Left Ventricular Ejection Fraction (LVEF)	No significant change	No significant change	.43
Skin Autofluorescence (AGE accumulation)	No significant change	No significant change	.42
NT-proBNP	No significant change	No significant change	.20
NYHA Functional Class	No significant change	No significant change	.73
Minnesota Living with Heart Failure Score	No significant change	No significant change	.38

Experimental Protocols

1. Open-Label Study in Diastolic Heart Failure (Little et al., 2005)

- Study Design: A 16-week, open-label, single-center trial.
- Participants: 23 elderly patients (mean age 71 years) with stable diastolic heart failure (ejection fraction >50%).
- Intervention: **Alagebrium** administered orally at a dose of 420 mg per day.

- Assessments:
 - Primary and Secondary Endpoints: Changes in left ventricular (LV) mass and diastolic function were the key outcomes of interest.
 - Imaging: Magnetic resonance imaging (MRI) was used to assess LV ejection fraction and mass. Doppler echocardiography was used to evaluate diastolic filling.
 - Functional Capacity: Peak exercise oxygen consumption was measured to assess exercise tolerance.
 - Arterial Compliance: Aortic distensibility was evaluated.
 - Quality of Life: The Minnesota Living with Heart Failure questionnaire was administered.

2. BENEFICIAL Randomized Controlled Trial in Systolic Heart Failure

- Study Design: A 36-week, double-blind, placebo-controlled, randomized, parallel-group, multicenter trial.[\[7\]](#)
- Participants: 102 patients with stable chronic heart failure (NYHA class II-IV) and a left ventricular ejection fraction (LVEF) of $\leq 45\%$.[\[7\]](#)
- Intervention: Patients were randomized to receive either **Alagebrium** (200 mg twice daily) or a matching placebo.[\[7\]](#)
- Assessments:
 - Primary Endpoint: The primary efficacy endpoint was the change in peak oxygen consumption (VO_2) during exercise testing.[\[2\]](#)
 - Secondary Endpoints: Secondary endpoints included changes in diastolic function (measured by E' and E/E' ratio), systolic function (LVEF), AGE accumulation (measured by skin autofluorescence), N-terminal pro-brain natriuretic peptide (NT-proBNP) levels, NYHA functional class, and quality of life (Minnesota Living with Heart Failure Questionnaire).[\[2\]](#)

Visualizations

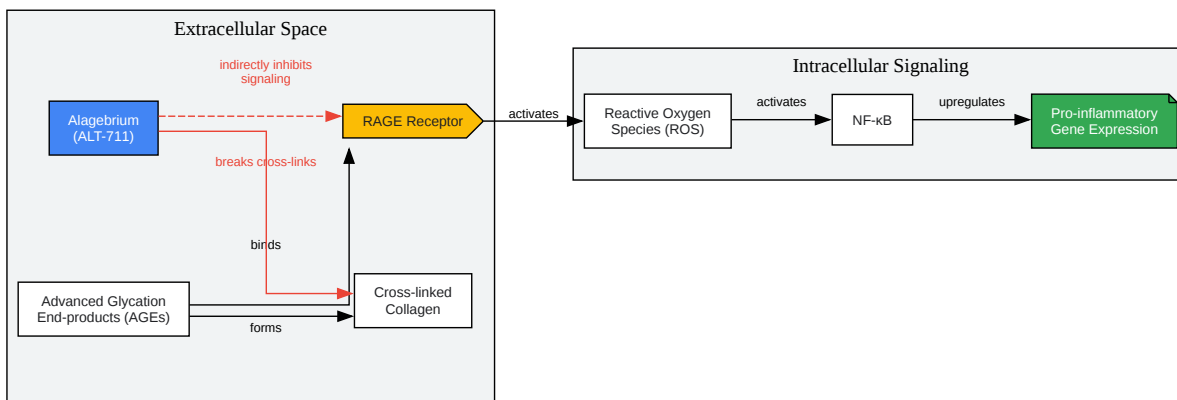

[Click to download full resolution via product page](#)

Caption: Proposed mechanism of action of **Alagebrium** (ALT-711).

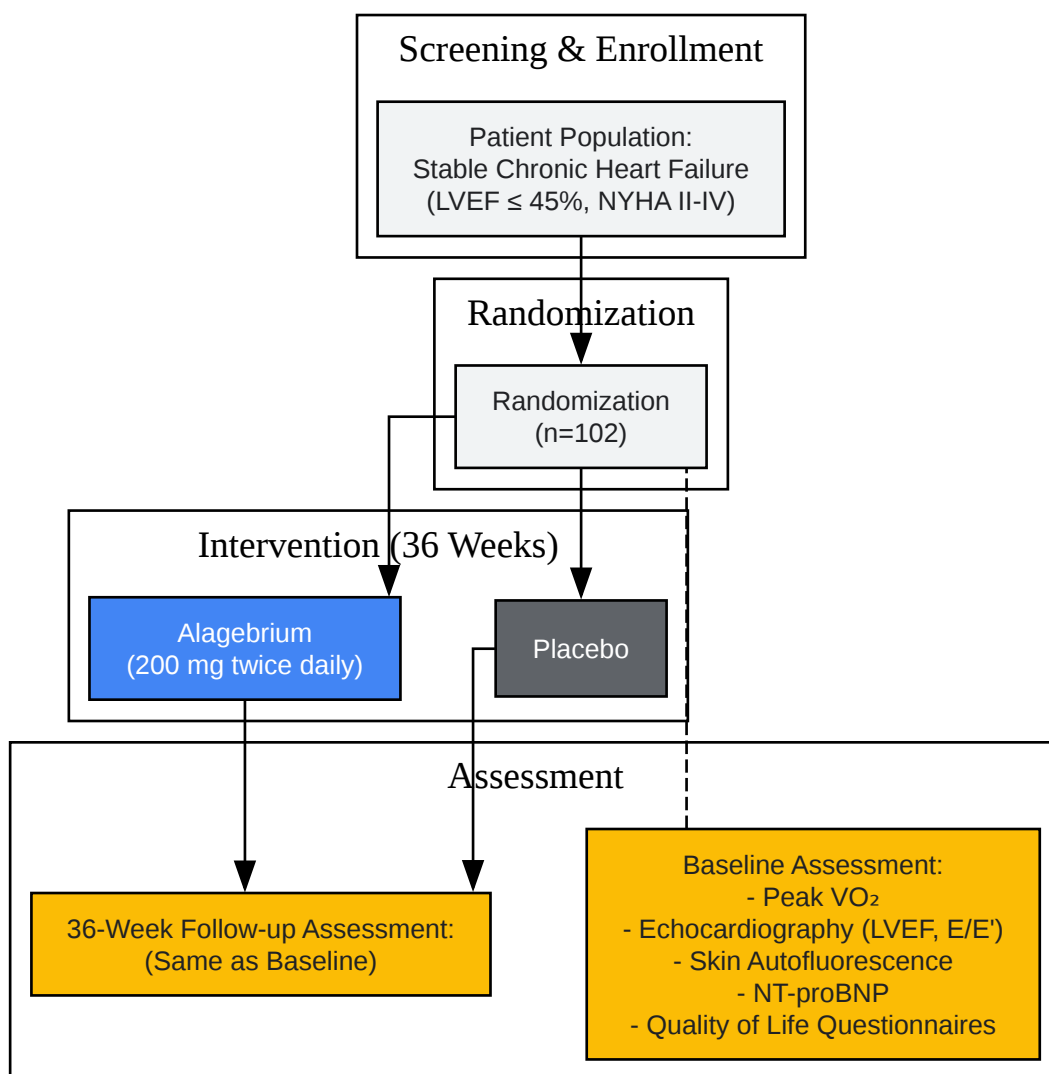

[Click to download full resolution via product page](#)

Need Custom Synthesis?

BenchChem offers custom synthesis for rare earth carbides and specific isotopic labeling.

Email: info@benchchem.com or [Request Quote Online](#).

References

- 1. Alagebrium and Complications of Diabetes Mellitus - PMC [pmc.ncbi.nlm.nih.gov]
- 2. Effects of alagebrium, an advanced glycation endproduct breaker, on exercise tolerance and cardiac function in patients with chronic heart failure - PubMed

[\[pubmed.ncbi.nlm.nih.gov\]](https://pubmed.ncbi.nlm.nih.gov)

- 3. The effect of alagebrium chloride (ALT-711), a novel glucose cross-link breaker, in the treatment of elderly patients with diastolic heart failure - PubMed [\[pubmed.ncbi.nlm.nih.gov\]](https://pubmed.ncbi.nlm.nih.gov)
- 4. Cardiovascular Effects of 1 Year of Alagebrium and Endurance Exercise Training in Healthy Older Individuals - PMC [\[pmc.ncbi.nlm.nih.gov\]](https://pmc.ncbi.nlm.nih.gov)
- 5. Pharmacologic Approaches Against Advanced Glycation End Products (AGEs) in Diabetic Cardiovascular Disease - PMC [\[pmc.ncbi.nlm.nih.gov\]](https://pmc.ncbi.nlm.nih.gov)
- 6. Advanced glycation end-product cross-link breakers. A novel approach to cardiovascular pathologies related to the aging process - PubMed [\[pubmed.ncbi.nlm.nih.gov\]](https://pubmed.ncbi.nlm.nih.gov)
- 7. Effects of alagebrium, an advanced glycation end-product breaker, in patients with chronic heart failure: study design and baseline characteristics of the BENEFICIAL trial - PubMed [\[pubmed.ncbi.nlm.nih.gov\]](https://pubmed.ncbi.nlm.nih.gov)
- To cite this document: BenchChem. [Alagebrium (ALT-711) Development: A Technical Support Analysis of its Discontinuation]. BenchChem, [2026]. [Online PDF]. Available at: [\[https://www.benchchem.com/product/b1220623/docs#alagebrium-alt-711-development-a-technical-support-analysis-of-its-discontinuation\]](https://www.benchchem.com/product/b1220623/docs#alagebrium-alt-711-development-a-technical-support-analysis-of-its-discontinuation)

Disclaimer & Data Validity:

The information provided in this document is for Research Use Only (RUO) and is strictly not intended for diagnostic or therapeutic procedures. While BenchChem strives to provide accurate protocols, we make no warranties, express or implied, regarding the fitness of this product for every specific experimental setup.

Technical Support: The protocols provided are for reference purposes. Unsure if this reagent suits your experiment?

Need Industrial/Bulk Grade? [Request Custom Synthesis Quote](#)

BenchChem

Our mission is to be the trusted global source of essential and advanced chemicals, empowering scientists and researchers to drive progress in science and industry.

Contact

Address: 3281 E Guasti Rd
Ontario, CA 91761, United States
Phone: (601) 213-4426
Email: info@benchchem.com

[Contact our Ph.D. Support Team for a compatibility check](#)