

Technical Support Center: Carbostyryl Epoxide Synthesis Optimization

Author: BenchChem Technical Support Team. **Date:** May 2026

Compound of Interest

Compound Name:	5-(2-Oxiranyl)-8-(phenylmethoxy)-2(1H)-quinolinone
CAS No.:	112281-28-4
Cat. No.:	B122331

[Get Quote](#)

Executive Summary & Reaction Logic

The synthesis of 7-(2,3-epoxypropoxy)-3,4-dihydroquinolin-2(1H)-one (Carbostyryl Epoxide) involves the nucleophilic substitution of 7-hydroxy-3,4-dihydrocarbostyryl (7-HQ) with epichlorohydrin (ECH).^[1]

While conceptually simple, this reaction is prone to three critical failure modes driven by the bifunctional nature of epichlorohydrin and the reactivity of the product:

- Dimerization (Oligomerization): The product (epoxide) competes with ECH for the phenoxide anion, leading to a "dimer" impurity (1,3-bis-ether).
- Incomplete Cyclization: Stalling at the chlorohydrin intermediate.
- Hydrolysis: Opening of the epoxide ring by residual water to form a diol.

Master Reaction Pathway

The following diagram illustrates the kinetic competition between the desired pathway and the primary byproduct cascades.

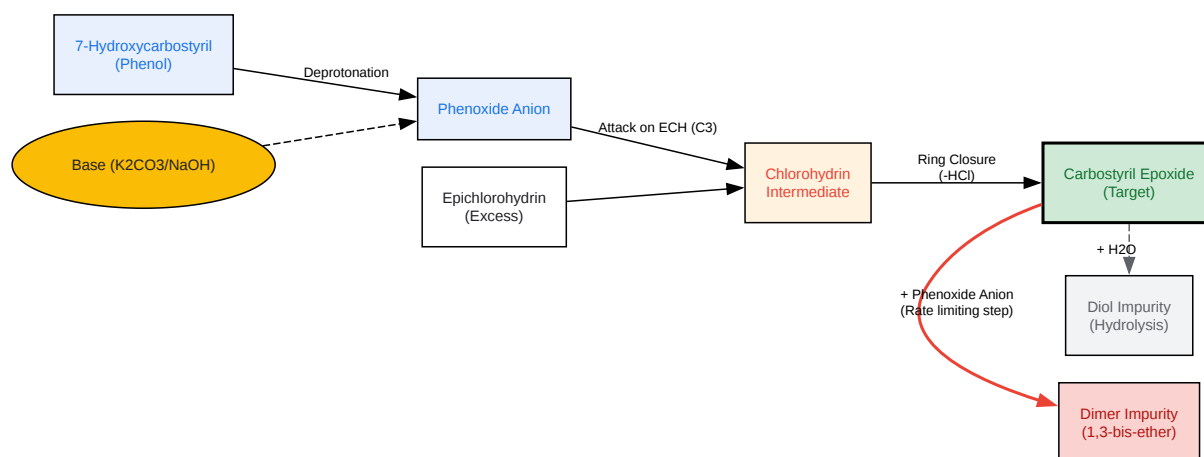

[Click to download full resolution via product page](#)

Figure 1: Mechanistic pathway showing the competition between the desired ring closure and the parasitic dimerization reaction.

Troubleshooting Guide (Q&A)

Category 1: Dimer Formation (The "Bis" Impurity)

User Question: My HPLC shows a large peak at RRT ~1.8-2.0. Mass spec confirms it's the dimer (MW ~380). How do I stop this?

Scientist Response: The dimer (1,3-bis(2-oxo-1,2,3,4-tetrahydroquinolin-7-yloxy)propan-2-ol) forms when a molecule of your product reacts with a molecule of starting material.^[1] This is a classic statistical probability issue.

- Root Cause: The concentration of the phenoxide anion is too high relative to the epichlorohydrin, or the reaction has proceeded too long, allowing the product to accumulate and compete for the nucleophile.
- Corrective Action:
 - Increase Epichlorohydrin Equivalents: You are likely using 1.5–2.0 equivalents. Increase this to 5.0–10.0 equivalents. This statistically forces the phenoxide to encounter ECH rather than the product. ECH can be distilled and recycled later.
 - Reverse Addition/Slow Addition: Do not dump the base into the phenol/ECH mixture. Instead, heat the phenol and ECH, then slowly feed the base (or the phenol/base mixture) into the hot ECH. This keeps the instantaneous concentration of the active phenoxide low.
 - Stop Early: Dimer formation accelerates towards the end of the reaction. Quench the reaction at 95-98% conversion rather than chasing the last 2%.

Category 2: Chlorohydrin Stalling

User Question: I see good conversion of the starting material, but a new peak (M+36/38) persists and won't close to the epoxide.

Scientist Response: You are stuck at the Chlorohydrin Intermediate (7-(3-chloro-2-hydroxypropoxy)-...).^[1] This intermediate requires a second equivalent of base to effect the intramolecular

ring closure.

- Root Cause: Insufficient base strength or "base exhaustion" (surface passivation of solid bases like K₂CO₃).
- Corrective Action:
 - Check Base Stoichiometry: Ensure you have at least 2.0–2.5 equivalents of base (1 eq for the phenol, 1 eq for the ring closure).
 - Add a Phase Transfer Catalyst (PTC): If using a solid base in an organic solvent (e.g., K₂CO₃ in acetone/acetonitrile), add 2–5 mol% Tetrabutylammonium Bromide (TBAB).

This transports the carbonate anion into the organic phase to facilitate the ring closure.

- Temperature Bump: The ring closure often has a higher activation energy than the initial opening. Raise the reaction temperature to reflux (approx. 60–80°C) for the final hour.

Category 3: Hydrolysis (Diol Formation)

User Question: My product purity is dropping during workup. I see a polar impurity increasing.

Scientist Response: The epoxide ring is sensitive to acid/base catalyzed hydrolysis, converting your glycidyl ether into the Diol (7-(2,3-dihydroxypropoxy)-...).[1]

- Root Cause: Exposure to water at high temperatures or extreme pH during workup.
- Corrective Action:
 - Dry Solvents: Ensure your reaction solvent (Acetonitrile, Acetone, or DMF) is dry (<0.1% water).
 - Cold Quench: Never quench the reaction with water while hot. Cool to <10°C before adding water.
 - pH Control: Avoid prolonged exposure to strong caustic (NaOH) during the wash. Neutralize quickly or use a brine wash to remove excess base.

Optimized Experimental Protocol

This protocol is designed to minimize dimer formation (<0.5%) and maximize yield (>90%).

Reagents:

- 7-Hydroxy-3,4-dihydrocarbostyryl (1.0 eq)[1]
- Epichlorohydrin (5.0 – 8.0 eq) — Critical for dimer suppression[1]
- Potassium Carbonate (2.5 eq, anhydrous, pulverized)
- Tetrabutylammonium Bromide (TBAB) (0.05 eq)[1]

- Solvent: Acetonitrile or Acetone (5-10 volumes)[1]

Step-by-Step Workflow:

- Charge the reactor with 7-Hydroxy-3,4-dihydrocarbostyryl, TBAB, and the solvent.
- Add Epichlorohydrin in one portion.
- Heat the mixture to 50°C.
- Slow Addition: Add the Potassium Carbonate in 4 equal portions over 2 hours.
 - Why? This limits the concentration of active phenoxide, preventing it from attacking the newly formed product.
- Reflux: After the final addition, heat to reflux (approx. 80°C for MeCN) and stir for 3–5 hours.
- IPC (In-Process Control): Check HPLC.
 - Target: Starting Material < 1.0%.
 - If Chlorohydrin > 2.0%, continue reflux for 1 hour.
- Workup:
 - Cool to 20°C.
 - Filter off inorganic salts (KCl/KHCO₃).
 - Distill off the solvent and excess epichlorohydrin under reduced pressure (recycle ECH).
 - Recrystallize the residue from Isopropanol/Hexane to remove trace dimer.

Data Summary: Solvent & Base Impact[2][3][4]

The choice of solvent and base dramatically shifts the impurity profile.

System	Dimer Formation	Reaction Rate	Recommendation
NaOH / Water (excess ECH)	Low	Very Fast	Industrial Standard. Hard to control exotherm.[1]
K ₂ CO ₃ / Acetone	High	Slow	Not Recommended. Poor solubility leads to stalling.
K ₂ CO ₃ / DMF	Moderate	Fast	Good, but DMF removal is difficult (high BP).
K ₂ CO ₃ / Acetonitrile + PTC	Lowest	Optimal	Best Balance. Easy workup, low dimer.

References

- General Glycidyl Ether Synthesis & Dimer Control
 - Method of synthesizing glycidyl ether compounds in the absence of water and organic solvents.[2][3] (US Patent 6392064B2). Describes the use of solid alkali and phase transfer catalysts to improve yield and reduce hydrolysis.
 - Source: [1]
- Aripiprazole/Carbostyryl Intermediate Synthesis
 - Process for the preparation of carbostyryl derivatives, such as aripiprazole and its intermediates. (WO2004099152A1).
 - Source: [1]
- Impurity Characterization
 - Chemical structures of aripiprazole and its impurities. (ResearchGate).[4] Identifies the specific structure of dimer and diol impurities in carbostyryl derivatives.

- Source: [1]
- Epichlorohydrin Reactivity & Mechanisms
 - Epoxide Synthesis and Ring-Opening Reactions.[1][5] (Encyclopedia.pub). Provides mechanistic insight into the competition between ring closure and oligomerization.
 - Source: [1]

Need Custom Synthesis?

BenchChem offers custom synthesis for rare earth carbides and specific isotopic labeling.

Email: info@benchchem.com or [Request Quote Online](#).

Sources

- [1. CN104356063A - Preparation method of 7-hydroxy-3,4-dihydro-2-\(1H\) carbostyryl - Google Patents \[patents.google.com\]](#)
- [2. US6392064B2 - Method of synthesizing glycidyl ether compounds in the absence of water and organic solvents - Google Patents \[patents.google.com\]](#)
- [3. odr.chalmers.se \[odr.chalmers.se\]](#)
- [4. researchgate.net \[researchgate.net\]](#)
- [5. application.wiley-vch.de \[application.wiley-vch.de\]](#)
- To cite this document: BenchChem. [Technical Support Center: Carbostyryl Epoxide Synthesis Optimization]. BenchChem, [2026]. [Online PDF]. Available at: [\[https://www.benchchem.com/product/b122331/docs#technical-support-center-carbostyryl-epoxide-synthesis-optimization\]](https://www.benchchem.com/product/b122331/docs#technical-support-center-carbostyryl-epoxide-synthesis-optimization)

Disclaimer & Data Validity:

The information provided in this document is for Research Use Only (RUO) and is strictly not intended for diagnostic or therapeutic procedures. While BenchChem strives to provide accurate protocols, we make no warranties, express or implied, regarding the fitness of this product for every specific experimental setup.

Technical Support: The protocols provided are for reference purposes. Unsure if this reagent suits your experiment?

Need Industrial/Bulk Grade? [Request Custom Synthesis Quote](#)

BenchChem

Our mission is to be the trusted global source of essential and advanced chemicals, empowering scientists and researchers to drive progress in science and industry.

Contact

Address: 3281 E Guasti Rd
Ontario, CA 91761, United States
Phone: (601) 213-4426
Email: info@benchchem.com

[Contact our Ph.D. Support Team for a compatibility check](#)