

Introduction: The Luminescence of Terbium and the Power of Flow Injection Analysis

Author: BenchChem Technical Support Team. **Date:** May 2026

Compound of Interest

Compound Name:	Terbium
CAS No.:	7440-27-9
Cat. No.:	B1219544

[Get Quote](#)

The determination of trace levels of lanthanides, such as **terbium** (Tb^{3+}), is crucial in fields ranging from environmental monitoring to pharmaceutical analysis and materials science. **Terbium** possesses unique luminescent properties, characterized by long-lived, sharp, and distinct emission peaks, making it an attractive target for optical detection methods.[1] However, the direct excitation of the Tb^{3+} ion is inefficient due to the Laporte-forbidden nature of its 4f electronic transitions, resulting in poor luminescence.[2]

To overcome this limitation, a technique known as sensitized luminescence, or the "antenna effect," is employed.[2] In this process, an organic ligand, or "antenna," coordinates with the Tb^{3+} ion. This ligand absorbs excitation energy efficiently and transfers it intramolecularly to the **terbium** ion, which then emits its characteristic luminescence.[1][2][3] This energy transfer dramatically enhances the emission signal, forming the basis for highly sensitive analytical methods.

Flow Injection Chemiluminescence (FI-CL) provides an ideal platform to exploit this phenomenon for quantitative analysis.[4] FI-CL is an automated technique that involves injecting a precise volume of a sample into a continuously flowing carrier stream.[5] This sample plug then merges with reagent streams, initiating a chemical reaction within a reaction

coil that produces light (chemiluminescence). The emitted light is measured by a detector, typically a photomultiplier tube (PMT), generating a signal directly proportional to the analyte's concentration.[4][6] The key advantages of FI-CL include high sample throughput, excellent reproducibility, minimal reagent consumption, and simple instrumentation.[4][7]

This application note details a robust FI-CL method for the determination of analytes that form complexes with **terbium**, using the **terbium**-sensitized enhancement of a chemiluminescence reaction. We will focus on the well-established Ce(IV)-SO₃²⁻ system as a representative example.

Principle of Terbium-Sensitized Chemiluminescence

The core of this analytical method is the significant enhancement of the weak chemiluminescence produced by the oxidation of sulfite (SO₃²⁻) by Cerium(IV) in an acidic medium. The presence of a Tb³⁺-analyte complex acts as a powerful catalyst and energy acceptor in this reaction.

The proposed mechanism involves several key steps:

- **Complex Formation:** The target analyte (e.g., a fluoroquinolone antibiotic) readily forms a stable complex with Tb³⁺ ions.[8][9]
- **Redox Reaction:** In the flow system, the injected sample containing the Tb³⁺-analyte complex mixes with streams of Ce(IV) and sulfite. The Ce(IV) oxidizes the sulfite, generating excited intermediates like SO₂*.
- **Energy Transfer:** An efficient energy transfer cascade occurs. First, energy is transferred from the excited reaction intermediate (SO₂*) to the analyte ligand within the complex. Subsequently, an intramolecular energy transfer takes place from the excited ligand to the central Tb³⁺ ion.[8]
- **Luminescent Emission:** The excited Tb³⁺ ion relaxes to its ground state by emitting photons at its characteristic wavelengths (with the most prominent peak around 545 nm), producing a strong CL signal.[1]

The intensity of this emitted light is directly proportional to the concentration of the Tb³⁺-analyte complex, and therefore, to the concentration of the analyte itself.

Experimental Workflow: Instrumentation and Setup

A standard FI-CL system can be assembled from commercially available components or purchased as a dedicated unit.[10] The core components include a peristaltic pump, an injection valve, PTFE tubing for reaction coils and connections, a flow-through cell, and a sensitive light detector.[5][7][10]

FI-CL Manifold Diagram

The logical flow of the FI-CL system is depicted below. The sample, containing the analyte and Tb^{3+} , is injected into a carrier stream. It then merges with the oxidant ($Ce(IV)$) and reductant (Na_2SO_3) streams, and the mixture flows through a reaction coil to the detector where the chemiluminescence is measured.

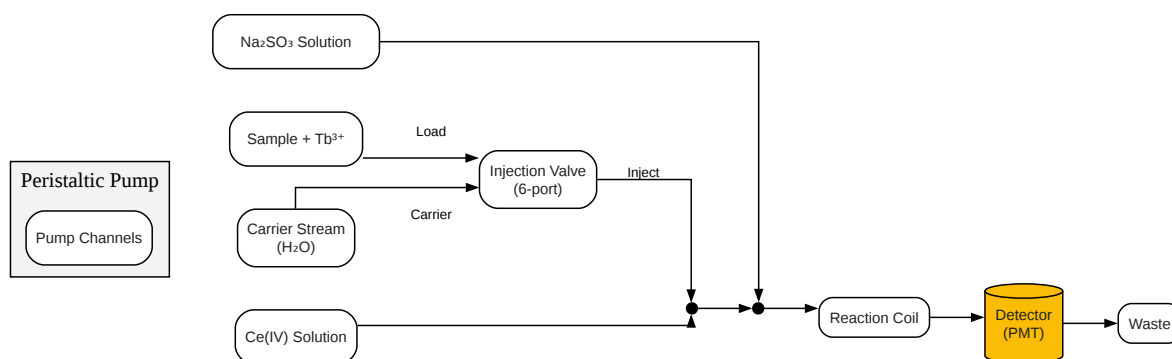

[Click to download full resolution via product page](#)

Caption: Diagram of the FI-CL manifold for **terbium**-sensitized analysis.

Detailed Protocol for Terbium Determination

This protocol provides a method for determining an analyte, such as the fluoroquinolone antibiotic Lomefloxacin (LFX), using **terbium**-sensitized FI-CL.[8]

PART 1: Reagent and Standard Preparation

- Prerequisite: All solutions must be prepared using ultrapure deionized water ($18.2 \text{ M}\Omega\cdot\text{cm}^{-1}$). All glassware and plasticware should be acid-washed (soaking in 6 M HCl for 24 hours), followed by thorough rinsing with deionized water to prevent metal contamination.[7]
- **Terbium(III) Chloride Stock Solution ($1.0 \times 10^{-2} \text{ M}$):**
 - Accurately weigh the required amount of **Terbium(III) chloride hexahydrate** ($\text{TbCl}_3\cdot 6\text{H}_2\text{O}$).
 - Dissolve in a small amount of deionized water in a 100 mL volumetric flask and dilute to the mark. Store in a refrigerator.
 - Scientist's Note: Lanthanide salts are hygroscopic. Ensure accurate weighing and proper storage.
- **Analyte (LFX) Stock Solution ($1.0 \times 10^{-3} \text{ M}$):**
 - Accurately weigh the required amount of Lomefloxacin hydrochloride.
 - Dissolve in and dilute to volume with deionized water in a 100 mL volumetric flask. This solution should be stored protected from light.
- **Cerium(IV) Sulfate Solution ($1.0 \times 10^{-3} \text{ M}$):**
 - Dissolve the required amount of $\text{Ce}(\text{SO}_4)_2$ in 2.0 M sulfuric acid and dilute to volume with the same acid.
 - Causality: The strong acidic medium is essential to keep Ce(IV) in its stable, soluble, and oxidative state, preventing hydrolysis and precipitation.[11]
- **Sodium Sulfite Solution ($1.0 \times 10^{-2} \text{ M}$):**
 - Dissolve the required amount of Na_2SO_3 in deionized water.
 - Scientist's Note: This solution is susceptible to air oxidation and should be prepared fresh daily for optimal performance and reproducibility.

- Working Standards:
 - Prepare a series of working standards by appropriate serial dilution of the LFX stock solution.
 - To each standard, add a fixed concentration of TbCl_3 (e.g., to a final concentration of 1.0×10^{-5} M). This ensures that **terbium** is in excess relative to the analyte, making the analyte the limiting factor for complex formation.

PART 2: Instrument Operation and Analysis

- System Setup:
 - Assemble the FI-CL manifold as shown in the diagram. Use PTFE tubing (e.g., 0.8 mm I.D.) for all connections.[\[10\]](#)
 - Set the peristaltic pump to deliver the optimized flow rates for the carrier, Ce(IV), and Na_2SO_3 streams (typically in the range of 1.0 - 2.5 mL/min).
 - Set the high voltage for the PMT. This is a critical parameter that balances signal amplification with background noise and should be optimized empirically.
- System Equilibration:
 - Pump all reagent solutions through the system until a stable, low-noise baseline is observed on the data acquisition software. This typically takes 10-15 minutes.
- Calibration:
 - Fill the injection loop (e.g., 100 μL) with the lowest concentration standard and inject it into the carrier stream by switching the valve.[\[10\]](#)
 - Record the peak height or area of the resulting CL signal.
 - Repeat the injection for each standard in ascending order of concentration. It is good practice to perform triplicate injections for each standard to ensure precision.

- Plot the average CL intensity (minus the blank signal) versus the analyte concentration to generate the calibration curve.
- Sample Measurement:
 - Prepare the unknown samples in the same manner as the working standards, ensuring the addition of the same fixed concentration of $TbCl_3$. For biological samples like urine or serum, a dilution and filtration step may be necessary to minimize matrix effects.[8][12][13]
 - Inject the prepared samples into the FI-CL system and record the CL intensity.
 - Self-Validation: It is crucial to run a quality control (QC) standard of a known concentration after every 10-15 unknown samples to verify the stability and accuracy of the system throughout the analytical run.
- System Shutdown:
 - After analysis, flush the entire system with deionized water for at least 20 minutes to remove all residual reagents and prevent salt crystallization in the tubing.

Analytical Performance and Applications

The FI-CL method offers excellent sensitivity and a wide dynamic range for the determination of various compounds that can complex with **terbium**. It has been successfully applied to the analysis of pharmaceuticals, particularly fluoroquinolone antibiotics, in both drug formulations and biological fluids.[8][9][14]

The table below summarizes typical performance characteristics for the determination of Lomefloxacin (LFX) and Enoxacin (ENX).

Parameter	Lomefloxacin (LFX)	Enoxacin (ENX)
Linear Range	2.0×10^{-9} - 1.0×10^{-5} M[8]	8.0×10^{-10} - 1.0×10^{-5} M[9]
Limit of Detection (LOD)	1.1×10^{-9} M[8]	2.4×10^{-10} M[9]
Relative Standard Deviation (RSD)	< 3.0%	< 2.0%
Sample Throughput	~80-120 injections/hour	~100 injections/hour[15]
Sample Matrix	Pharmaceutical preparations, Urine, Serum[8]	Dosage forms, Urine[9]

Method Validation: For use in regulated environments, the method must be fully validated according to established guidelines (e.g., ICH Q2(R1)).[3] This involves rigorously assessing parameters such as linearity, accuracy (recovery studies), precision (repeatability and intermediate precision), selectivity, LOD, and LOQ.[16][17][18] Recovery studies in biological matrices like urine and serum have shown excellent results, typically in the range of 95-105%, demonstrating the method's accuracy and freedom from significant matrix interference.[8]

Conclusion

Flow Injection Chemiluminescence coupled with **terbium** sensitization is a powerful analytical technique that provides a simple, rapid, and highly sensitive method for the determination of a wide range of organic compounds. By leveraging the unique luminescent properties of **terbium** and the automated, reproducible nature of flow injection analysis, this method offers a compelling alternative to more complex and time-consuming techniques like chromatography. The protocols and principles outlined in this guide provide a solid foundation for researchers and drug development professionals to implement this robust analytical tool in their laboratories.

References

- Design of an Automated Flow Injection-Chemiluminescence Instrument Incorporating a Miniature Photomultiplier Tube for Monitoring - SciSpace. Available at: [\[Link\]](#)

- Nie, L. H., Zhao, H. C., Wang, X., Yi, L., Lu, Y., Jin, L. P., & Ma, H. M. (2002). Determination of lomefloxacin by **terbium** sensitized chemiluminescence method. *Analytical and Bioanalytical Chemistry*, 374(7-8), 1187–1190. Available at: [\[Link\]](#)
- Components and Instruments - Programmable Flow Injection Analysis. Faculty of Pharmacy - Research Portal, Charles University. Available at: [\[Link\]](#)
- Wang, Z., Liu, Z., Chen, H., Mei, J., & Li, H. (2021). A cyclic peptide antenna ligand for enhancing **terbium** luminescence. *RSC Advances*, 11(28), 17201–17205. Available at: [\[Link\]](#)
- Yi, L., Zhao, H. C., Chen, S. L., Jin, L. P., Zheng, D. D., & Wu, Z. L. (2003). Flow-injection analysis of two fluoroquinolones by the sensitizing effect of **terbium(III)** on chemiluminescence of the potassium permanganate-sodium sulfite system. *Talanta*, 61(3), 403–409. Available at: [\[Link\]](#)
- Al-Lawati, H. A. J., Al-Kindy, S. M. Z., Suliman, F. E. O., & Al-Harrasi, A. S. S. (2023). Transparent Cross-Flow Platform as Chemiluminescence Detection Cell in Cross Injection Analysis. *Sensors (Basel, Switzerland)*, 23(3), 1515. Available at: [\[Link\]](#)
- Application of f-f luminescence of **terbium** ion for determination of non-steroidal anti-inflammatory drug-niflumic acid. ResearchGate. Available at: [\[Link\]](#)
- Automated Flow-Injection Instrument for Chemiluminescence Detection Using a Low-Cost Photodiode Detector: An Interdisciplinary Project in Chemical Instrumentation, Graphical Programming, Computer Interfacing, and Analytical Chemistry. ResearchGate. Available at: [\[Link\]](#)
- Harvey, D. (2013). Instrumentation for Flow Injection Analysis. Image and Video Exchange Forum. Available at: [\[Link\]](#)
- Takahashi, Y., Tanaka, D. A. P., Matsunaga, H., & Suzuki, T. M. (2002). Switching of **Terbium(III)**-sensitized Luminescence by Ligand Exchange Reaction: Determination of Catecholamines. *Chemistry Letters*, 31(5), 458–459. Available at: [\[Link\]](#)
- **Terbium(III)** Luminescence-Based Assay for Esterase Activity. (2018). *ACS Omega*, 3(10), 14213–14220. Available at: [\[Link\]](#)

- Effective and efficient sensitisation of **terbium** luminescence at 355 nm with cell permeable pyrazoyl-1-azaxanthone macrocyclic complexes. (2014). *Chemical Communications*, 50(64), 8966-8969. Available at: [\[Link\]](#)
- Gáspár, A., & Pápay, Z. E. (2001). Chemiluminescence-based detection: principles and analytical applications in flowing streams and in immunoassays. *Luminescence : the journal of biological and chemical luminescence*, 16(3), 187–193. Available at: [\[Link\]](#)
- Al-Okab, M. A., Al-Ghamdi, A. A., El-Tohamy, M. F., Al-Maythalony, B. A., & Al-Enazi, N. M. (2023). New **Terbium** Complex as a Luminescent Sensor for the Highly Selective Detection of Malathion in Water Samples. *Molecules (Basel, Switzerland)*, 28(23), 7793. Available at: [\[Link\]](#)
- Derayea, S. M., El-Shabrawy, Y., & El-Wakil, M. M. (2022). Novel sensing probe using **Terbium**-sensitized luminescence and 8-hydroxyquinoline for determination of prucalopride succinate: green assessment with Complex-GAPI and analytical Eco-Scale. *Scientific reports*, 12(1), 17571. Available at: [\[Link\]](#)
- **Terbium** Excitation Spectroscopy as a Detection Method for Chromatographic Separation of Lanthanide-Binding Biomolecules. (2020). *ACS Omega*, 5(42), 27364-27371. Available at: [\[Link\]](#)
- [Flow injection analysis of ciprofloxacin by **terbium** sensitized chemiluminescence method]. ResearchGate. Available at: [\[Link\]](#)
- Novel **terbium**-sensitizing peptide substrates for cyclin-dependent kinase 5 (CDK5) and their demonstration in luminescence kinase assays. (2022). *RSC Chemical Biology*, 3(12), 1475-1481. Available at: [\[Link\]](#)
- Takahashi, Y., Tanaka, D. A. P., Matsunaga, H., & Suzuki, T. M. (2002). Switching of **Terbium(III)**-sensitized Luminescence by Ligand Exchange Reaction: Determination of Catecholamines. ResearchGate. Available at: [\[Link\]](#)
- Lin, J. M., & Lu, J. R. (2007). Flow Injection Technique for Biochemical Analysis with Chemiluminescence Detection in Acidic Media. *Sensors (Basel, Switzerland)*, 7(4), 442–456. Available at: [\[Link\]](#)

- A validated analytical method to measure metals dissolved in deep eutectic solvents. (2023). Scientific Reports, 13(1), 7990. Available at: [\[Link\]](#)
- Appraisal and validation of a method used for detecting heavy metals in poultry feed in Bangladesh. (2022). Veterinary World, 15(9), 2217-2223. Available at: [\[Link\]](#)
- Jin, F., She, Y., Shao, H., Wang, S., & Zheng, L. (2017). A review of enhancers for chemiluminescence enzyme immunoassay. Luminescence, 32(4), 425–431. Available at: [\[Link\]](#)
- Journal of Chemical Education. ACS Publications. Available at: [\[Link\]](#)
- Han, Y., Wang, L., & Liu, W. (2005). Flow injection chemiluminescence determination of N-tetrahydrobenzothiazolyl imines. Luminescence : the journal of biological and chemical luminescence, 20(3), 168–172. Available at: [\[Link\]](#)
- (PDF) Determination of fluorine and chlorine in standard steel residues and zinc sulfide concentrates by ion chromatography-Matrix interference study. ResearchGate. Available at: [\[Link\]](#)
- (PDF) Validation of an analytical method for the determination of cadmium, lead and mercury in fish and fishery resources by graphite furnace and Cold Vapor Atomic Absorption Spectrometry. ResearchGate. Available at: [\[Link\]](#)
- Arman, M. Ö., Mullaliu, A., Geboes, B., Van Hecke, K., Das, G., Aquilanti, G., Binnemans, K., & Cardinaels, T. (2024). Separation of **terbium** as a first step towards high purity **terbium**-161 for medical applications. Dalton transactions (Cambridge, England : 2003). Available at: [\[Link\]](#)
- Determination of the Mechanisms of **Terbium**(III) Biosorption by Bacillus Strains with Adsorption Selectivity for Heavy Rare Earth Elements. (2024). International Journal of Molecular Sciences, 25(7), 3986. Available at: [\[Link\]](#)
- (PDF) Physico-chemical characterization of the **terbium**-161 radioisotope through separation based on cartridge LN resin column from irradiated of enriched Gd 2 O 3 target. ResearchGate. Available at: [\[Link\]](#)

- Development and Validation of Method for Determination of Chloride in Surfactant Sample Using Auto-Titrator. ResearchGate. Available at: [\[Link\]](#)
- Webster, B. (2021). The chemical separation of **terbium** for applications in nuclear medicine. University of Surrey. Available at: [\[Link\]](#)
- Ri-Ichi, K. (2006). Determination of thallium in biological samples. Analytical and Bioanalytical Chemistry, 385(4), 665–670. Available at: [\[Link\]](#)
- Korfmacher, W. A., Semsen, S., Mawhinney, T. P., & Thompson, H. C. (1987). Determination of drugs in biological samples by thin-layer chromatography-tandem mass spectrometry. Journal of analytical toxicology, 11(5), 182–186. Available at: [\[Link\]](#)
- Fluorine - Wikipedia. Available at: [\[Link\]](#)

Need Custom Synthesis?

BenchChem offers custom synthesis for rare earth carbides and specific isotopic labeling.

Email: info@benchchem.com or [Request Quote Online](#).

Sources

1. A cyclic peptide antenna ligand for enhancing terbium luminescence - PMC [\[pmc.ncbi.nlm.nih.gov\]](#)
2. New Terbium Complex as a Luminescent Sensor for the Highly Selective Detection of Malathion in Water Samples | MDPI [\[mdpi.com\]](#)
3. Novel sensing probe using Terbium-sensitized luminescence and 8-hydroxyquinoline for determination of prucalopride succinate: green assessment with Complex-GAPI and analytical Eco-Scale - PMC [\[pmc.ncbi.nlm.nih.gov\]](#)
4. Chemiluminescence-based detection: principles and analytical applications in flowing streams and in immunoassays - PubMed [\[pubmed.ncbi.nlm.nih.gov\]](#)
5. [asplib.org](#) [\[asplib.org\]](#)
6. Transparent Cross-Flow Platform as Chemiluminescence Detection Cell in Cross Injection Analysis - PMC [\[pmc.ncbi.nlm.nih.gov\]](#)
7. [scispace.com](#) [\[scispace.com\]](#)

- [8. Determination of lomefloxacin by terbium sensitized chemiluminescence method - PubMed \[pubmed.ncbi.nlm.nih.gov\]](#)
- [9. Flow-injection analysis of two fluoroquinolones by the sensitizing effect of terbium\(III\) on chemiluminescence of the potassium permanganate-sodium sulfite system - PubMed \[pubmed.ncbi.nlm.nih.gov\]](#)
- [10. Programmable Flow Injection Analysis | Faculty of Pharmacy - Research Portal \[portal.faf.cuni.cz\]](#)
- [11. researchgate.net \[researchgate.net\]](#)
- [12. Determination of thallium in biological samples - PubMed \[pubmed.ncbi.nlm.nih.gov\]](#)
- [13. Determination of drugs in biological samples by thin-layer chromatography-tandem mass spectrometry - PubMed \[pubmed.ncbi.nlm.nih.gov\]](#)
- [14. researchgate.net \[researchgate.net\]](#)
- [15. Flow injection chemiluminescence determination of -tetrahydrobenzothiazolyl imines - Analyst \(RSC Publishing\) \[pubs.rsc.org\]](#)
- [16. A validated analytical method to measure metals dissolved in deep eutectic solvents - RSC Advances \(RSC Publishing\) DOI:10.1039/D3RA02372A \[pubs.rsc.org\]](#)
- [17. Appraisal and validation of a method used for detecting heavy metals in poultry feed in Bangladesh - PubMed \[pubmed.ncbi.nlm.nih.gov\]](#)
- [18. researchgate.net \[researchgate.net\]](#)
- [To cite this document: BenchChem. \[Introduction: The Luminescence of Terbium and the Power of Flow Injection Analysis\]. BenchChem, \[2026\]. \[Online PDF\]. Available at: \[https://www.benchchem.com/product/b1219544/docs#introduction-the-luminescence-of-terbium-and-the-power-of-flow-injection-analysis\]](#)

Disclaimer & Data Validity:

The information provided in this document is for Research Use Only (RUO) and is strictly not intended for diagnostic or therapeutic procedures. While BenchChem strives to provide accurate protocols, we make no warranties, express or implied, regarding the fitness of this product for every specific experimental setup.

Technical Support: The protocols provided are for reference purposes. Unsure if this reagent suits your experiment?

Need Industrial/Bulk Grade? [Request Custom Synthesis Quote](#)

BenchChem

Our mission is to be the trusted global source of essential and advanced chemicals, empowering scientists and researchers to drive progress in science and industry.

Contact

Address: 3281 E Guasti Rd
Ontario, CA 91761, United States
Phone: (601) 213-4426
Email: info@benchchem.com

[Contact our Ph.D. Support Team for a compatibility check](#)