

Application Notes & Protocols: A Strategic Guide to Penitricin Structure-Activity Relationship (SAR) Studies

Author: BenchChem Technical Support Team. **Date:** April 2026

Compound of Interest

Compound Name:	Penitricin
CAS No.:	92279-91-9
Cat. No.:	B1219807

[Get Quote](#)

Introduction: Unlocking the Potential of Penitricin

Penitricin, a novel antibiotic isolated from *Penicillium aculeatum*, represents a unique chemical scaffold with promising activity, particularly against Gram-negative bacteria.[1][2][3] Its core structure, hydroxymethylcyclopropenone, distinguishes it from many conventional antibiotics, suggesting a potentially novel mechanism of action and a pathway to overcoming existing resistance.[1][2][4] However, the raw potential of a natural product is rarely its final therapeutic form. Structure-Activity Relationship (SAR) studies are fundamental to the drug discovery process, providing a systematic methodology to explore how modifications to a molecule's structure influence its biological activity.[5][6]

This guide provides a comprehensive framework for designing and executing an SAR study for **Penitricin**. The objective is to rationally design, synthesize, and evaluate a library of **Penitricin** analogs to identify derivatives with enhanced potency, improved selectivity, and favorable pharmacological properties. We will move from foundational strategic planning and

computational design to detailed, validated protocols for biological evaluation and data interpretation, creating a self-reinforcing cycle of optimization.

Part 1: Strategic Design of the Penitricin Analog Library

The success of an SAR campaign hinges on the thoughtful design of the analog library. The goal is not to synthesize compounds randomly, but to make targeted modifications that probe specific hypotheses about the molecule's interaction with its biological target. Studies have already indicated that the core hydroxymethylcyclopropenone skeleton is essential for its antimicrobial effects.^{[4][7]} Therefore, our initial strategy will focus on modifying the peripheral groups while maintaining this core structure.

1.1. Identifying Key Modification Vectors

Based on the structure of **Penitricin** (hydroxymethylcyclopropenone), we can identify three primary vectors for chemical modification:

- **Vector 1 (R1): The Hydroxymethyl Group:** This is a key site for exploring the impact of size, polarity, and hydrogen bonding capacity. Modifications could include:
 - **Alkylation:** Replacing the hydroxyl hydrogen with methyl, ethyl, or larger groups to probe steric tolerance.
 - **Esterification/Etherification:** To modulate lipophilicity and potential prodrug strategies.
 - **Halogenation:** Replacing the hydroxyl with fluorine or chlorine to alter electronic properties and metabolic stability.
 - **Amination:** Introducing basic groups to explore new binding interactions.
- **Vector 2 (R2 & R3): The Cyclopropenone Ring:** While the core is vital, substitutions on the ring itself can explore electronic and steric effects.
 - **Alkylation:** Adding small alkyl groups (e.g., methyl) to the ring carbons.

- **Electronic Modulation:** Introducing electron-withdrawing or electron-donating groups to understand their impact on ring reactivity and target binding.

1.2. The Role of Computational Modeling

Before embarking on extensive synthesis, computational methods can prioritize the most promising analogs, saving considerable time and resources.[\[8\]](#)[\[9\]](#)

- **Quantitative Structure-Activity Relationship (QSAR):** If an initial dataset of a few analogs exists, QSAR models can be built to correlate physicochemical properties (like lipophilicity (cLogP), polar surface area, and electronic properties) with biological activity.[\[8\]](#)[\[10\]](#)[\[11\]](#) This can help predict the activity of unsynthesized compounds.
- **Molecular Docking:** If the biological target of **Penitricin** is known or can be hypothesized, molecular docking can be used to predict the binding modes of designed analogs.[\[6\]](#)[\[8\]](#) This allows for the rational design of modifications that are predicted to enhance binding affinity.

The overall workflow for designing the analog library follows an iterative cycle, integrating computational insights with synthetic feasibility and biological testing.

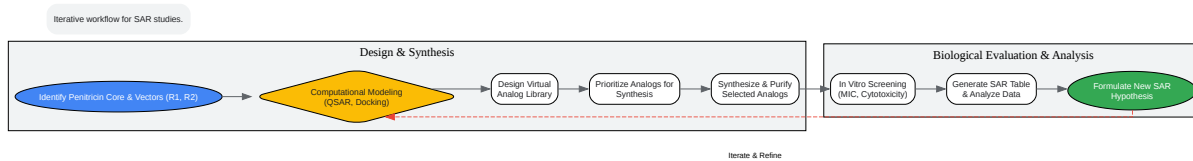

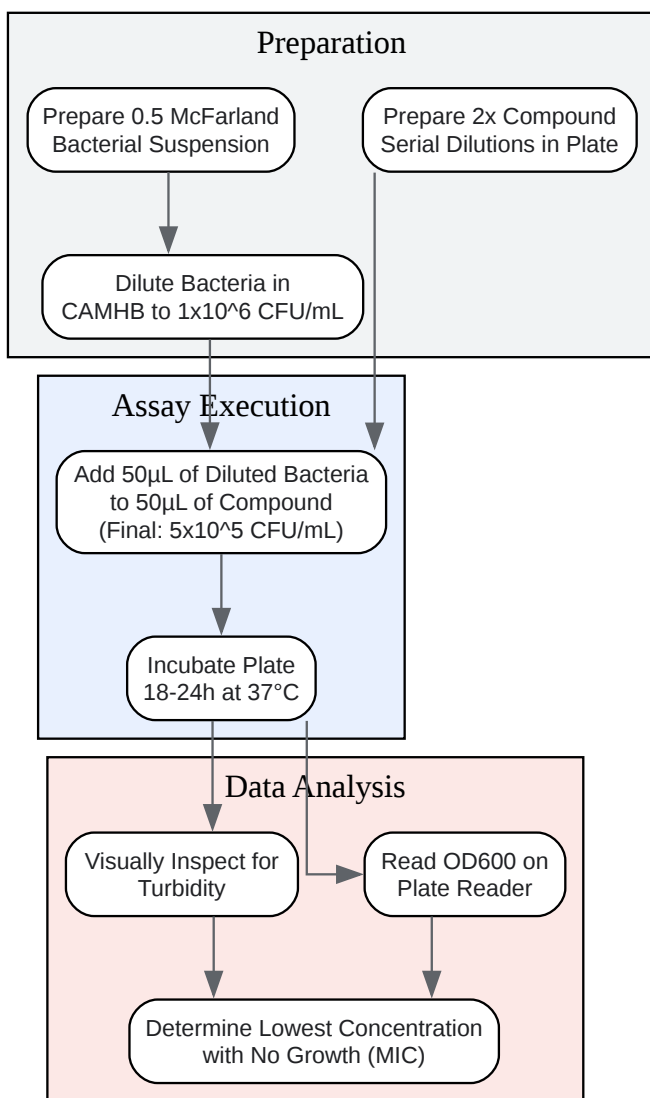

Workflow for Broth Microdilution MIC Assay.

[Click to download full resolution via product page](#)

Caption: Workflow for Broth Microdilution MIC Assay.

2.2. Secondary Screening: Selectivity and Toxicity

A potent antibiotic is only useful if it is not toxic to human cells. Therefore, analogs that show promising MIC values (e.g., <16 µg/mL) must be evaluated for cytotoxicity.

Protocol 2: MTT Cytotoxicity Assay

This assay measures the metabolic activity of mammalian cells as an indicator of cell viability. [12][13][14] A reduction in metabolic activity suggests the compound is cytotoxic.

Objective: To determine the concentration of a **Penitricin** analog that reduces the viability of a mammalian cell line by 50% (CC₅₀).

Materials:

- Human cell line (e.g., HEK293 or HepG2)
- Complete culture medium (e.g., DMEM + 10% FBS)
- 96-well, sterile, tissue-culture treated plates
- MTT reagent (3-(4,5-dimethylthiazol-2-yl)-2,5-diphenyltetrazolium bromide), 5 mg/mL in PBS
- Solubilization solution (e.g., DMSO or a solution of 10% SDS in 0.01 M HCl)
- Positive control (e.g., Doxorubicin)

Procedure:

- Cell Seeding: a. Seed the 96-well plate with cells at a density of 1×10^4 cells/well in 100 μ L of complete medium. b. Incubate for 24 hours at 37°C, 5% CO₂ to allow cells to attach.
- Compound Treatment: a. Prepare 2-fold serial dilutions of the **Penitricin** analogs in culture medium. b. Remove the old medium from the cells and add 100 μ L of the compound dilutions to the wells. Include vehicle-only (e.g., 0.5% DMSO) and untreated controls. c. Incubate for 24-48 hours at 37°C, 5% CO₂.
- MTT Addition and Incubation: a. Add 10 μ L of the 5 mg/mL MTT reagent to each well. [12] b. Incubate for 3-4 hours at 37°C, allowing viable cells to convert the yellow MTT to purple formazan crystals.
- Solubilization and Measurement: a. Carefully remove the medium. b. Add 100 μ L of solubilization solution to each well to dissolve the formazan crystals. [12] c. Shake the plate

on an orbital shaker for 15 minutes to ensure complete dissolution. [13] d. Measure the absorbance at 570 nm using a microplate reader.

- Data Analysis: a. Calculate the percentage of cell viability relative to the vehicle control. b. Plot the percent viability against the compound concentration (log scale) and use non-linear regression to determine the CC_{50} value.

Protocol 3: Hemolysis Assay

This assay provides a rapid screen for membrane-disrupting activity against red blood cells (RBCs), a key indicator of non-specific toxicity. [15][16][17] Objective: To determine the concentration of a **Penitricin** analog that causes 50% lysis of human red blood cells (HC_{50}).

Materials:

- Fresh human whole blood with anticoagulant (e.g., heparin)
- Phosphate-Buffered Saline (PBS), pH 7.4
- 96-well, sterile, V-bottom plates
- Positive control: 1% Triton X-100 in PBS
- Negative control: PBS

Procedure:

- RBC Preparation: a. Centrifuge whole blood at 500 x g for 5 minutes. [15] b. Aspirate the supernatant and plasma. Resuspend the RBC pellet in PBS. c. Repeat the wash step two more times. d. Prepare a 4% (v/v) suspension of the washed RBCs in PBS.
- Assay Setup: a. In a 96-well plate, add 100 μ L of serially diluted **Penitricin** analogs (in PBS). Include positive and negative controls. b. Add 100 μ L of the 4% RBC suspension to each well, resulting in a final RBC concentration of 2%. [17]3. Incubation: a. Incubate the plate at 37°C for 1 hour. [17]4. Measurement: a. Centrifuge the plate at 800 x g for 5 minutes to pellet intact RBCs. b. Carefully transfer 100 μ L of the supernatant to a new flat-bottom 96-well plate. c. Measure the absorbance of the supernatant at 450 nm or 540 nm to quantify hemoglobin release. [16][17]5. Data Analysis: a. Calculate the percentage of hemolysis using

the formula: % Hemolysis = $[(\text{Abs_sample} - \text{Abs_negative_control}) / (\text{Abs_positive_control} - \text{Abs_negative_control})] \times 100$. [17] b. Plot % hemolysis vs. concentration to determine the HC_{50} .

Part 3: Data Analysis & SAR Interpretation

The data from the primary and secondary screens must be collated and analyzed to derive meaningful SAR trends.

3.1. The SAR Table

A well-structured SAR table is the most critical tool for this analysis. It allows for the direct comparison of structural modifications with their biological outcomes.

Table 1: Hypothetical SAR Data for **Penitricin** Analogs

Analog ID	Modification (R1)	MIC ($\mu\text{g/mL}$) vs. E. coli	CC_{50} (μM) vs. HEK293	Selectivity Index (SI = $\text{CC}_{50}/\text{MIC}$)
PN-01 (Parent)	-CH ₂ OH	8	>100	>12.5
PN-02	-CH ₂ OCH ₃	4	>100	>25
PN-03	-CH ₂ F	16	80	5
PN-04	-CH ₂ NH ₂	32	50	1.6
PN-05	-CH ₂ O-acetyl	2	>100	>50
PN-06	-H	64	>100	>1.5

Note: MIC values should be converted to molar concentrations (μM) for accurate SI calculation.

3.2. Interpreting the Results

From the hypothetical data in Table 1, we can draw initial conclusions:

- Hydroxyl group is important: Removing the entire hydroxymethyl group (PN-06) significantly reduces activity, confirming its importance.

- Polarity and H-bonding: Replacing the hydroxyl with a less polar ether (PN-02) or an ester (PN-05) improves or maintains potency, suggesting the hydrogen-bond donating ability of the -OH is not essential and that modulating lipophilicity could be beneficial. The ester (PN-05) is particularly interesting as a potential lead.
- Toxicity concerns: Introducing a basic amine (PN-04) or a fluoro group (PN-03) decreases antimicrobial activity and increases cytotoxicity, resulting in a poor Selectivity Index. These pathways should be deprioritized.

These insights directly feed back into the design phase (see workflow diagram), guiding the synthesis of a second generation of analogs. For example, based on the success of PN-05, one might explore other ester groups with varying chain lengths to further optimize potency and pharmacokinetic properties.

Conclusion

The experimental design for a **Penitricin** SAR study is a multi-faceted, iterative process that combines rational molecular design, robust chemical synthesis, and a tiered biological screening approach. By systematically modifying the **Penitricin** scaffold and evaluating each analog for both potency (MIC) and selectivity (cytotoxicity, hemolysis), researchers can build a comprehensive understanding of the key structural features required for antibacterial activity. This knowledge-driven approach is essential for transforming a promising natural product into a viable drug candidate capable of addressing the growing challenge of antimicrobial resistance.

References

- Okuda, T., Shimma, N., & Furumai, T. (1984). **Penitricin**, a new class of antibiotic produced by *Penicillium aculeatum*. III. Structural confirmation by chemical synthesis and biological activity. *The Journal of Antibiotics*, 37(7), 723-727. [[Link](#)]
- Filo. (2026, February 17). Explain the structure activity relationship by giving examples with penicillin. Filo. [[Link](#)]
- Luu, K. T., Kuenemann, M. A., & Engkvist, O. (2022). Interpreting quantitative structure-activity relationship models to guide drug discovery. *Journal of Computer-Aided Molecular Design*, 36(10), 639-653. [[Link](#)]

- OncoDesign Services. Structure-Activity Relationship (SAR) Studies. [[Link](#)]
- Walsh Medical Media. (2025, June 28). Computational Approaches in Drug Discovery and Development. [[Link](#)]
- Isaka, M., Nakamura, E., et al. (1993). Synthesis and biological activities of cyclopropenone antibiotic **penitricin** and congeners. The Journal of Antibiotics, 46(10), 1568-1574. [[Link](#)]
- Bio-protocol. (2021). MTT Assay for Cytotoxicity Evaluation. [[Link](#)]
- Creative Biolabs. SAR & QSAR Model. [[Link](#)]
- Mio, Y., & Hdeib, M. (2013). Ex Vivo Red Blood Cell Hemolysis Assay for the Evaluation of pH-responsive Endosomolytic Agents for Cytosolic Delivery of Biomacromolecular Drugs. Journal of Visualized Experiments, (73), e50240. [[Link](#)]
- Mehta, A. P. (2025). Role Of Computational Modeling In Pharmaceutical Drug Design And Analysis. Journal of Pharmaceutical Analysis and Drug Research, 7(2), 113-124. [[Link](#)]
- Clinical and Laboratory Standards Institute. Antimicrobial Susceptibility Testing. [[Link](#)]
- Springer Nature Experiments. Cytotoxicity MTT Assay Protocols and Methods. [[Link](#)]
- Clinical and Laboratory Standards Institute. (2020). M100: Performance Standards for Antimicrobial Susceptibility Testing, 30th Edition. [[Link](#)]
- Okuda, T., Shimma, N., & Furumai, T. (1984). **Penitricin**, a new class of antibiotic produced by *Penicillium aculeatum*. III. Structural confirmation by chemical synthesis and biological activity. Semantic Scholar. [[Link](#)]
- CLSI. M100: Performance Standards for Antimicrobial Susceptibility Testing. [[Link](#)]
- Evotec. Hemolysis | Cyprotex ADME-Tox Solutions. [[Link](#)]
- Humphries, R. M., et al. (2023). Overview of changes in the Clinical and Laboratory Standards Institute Performance Standards for Antimicrobial Susceptibility Testing: M100 32nd and 33rd editions. Journal of Clinical Microbiology, 61(8), e00348-23. [[Link](#)]

- Isaka, M., et al. (1993). SYNTHESIS AND BIOLOGICAL ACTIVITIES OF CYCLOPROPENONE ANTIBIOTIC **PENITRICIN** AND CONGENERS. The Journal of Antibiotics, 46(10), 1568-1574. [[Link](#)]
- Anderson, R. K., et al. (1993). Synthesis and structure-activity relationships of some 6 beta-acrylamido penicillins. The Journal of Antibiotics, 46(2), 331-342. [[Link](#)]
- U.S. Food & Drug Administration. (2026, February 5). Antibacterial Susceptibility Test Interpretive Criteria. [[Link](#)]
- Pérez-Peinado, C., et al. (2024). Design, synthesis and structure-activity relationship (SAR) studies of an unusual class of non-cationic fatty amine-tripeptide conjugates as novel synthetic antimicrobial agents. Frontiers in Pharmacology, 15, 1428409. [[Link](#)]
- International Journal of Emerging Trends in Chemistry. (2025, May 10). Structure-Activity Relationship (SAR) Analysis of Newly Synthesized Antimicrobial Agents. [[Link](#)]
- Pérez-Peinado, C., et al. (2024). Design, synthesis and structure-activity relationship (SAR) studies of an unusual class of non-cationic fatty amine-tripeptide conjugates as novel synthetic antimicrobial agents. Frontiers in Pharmacology, 15. [[Link](#)]
- Jeků, J., et al. (2023). Optimization of the Hemolysis Assay for the Assessment of Cytotoxicity. International Journal of Molecular Sciences, 24(3), 2901. [[Link](#)]
- Study.com. Penicillin Uses, Mechanism of Action & Side Effects. [[Link](#)]
- Slideshare. Penicillins- Mechanism of action, Antimicrobial spectrum & Antibacterial resistance. [[Link](#)]
- ResearchGate. Diagram of the structure-activity relationship of penicillins. [[Link](#)]
- Al-Ostath, A., et al. (2024). Synthesis and Structure-Activity Relationship (SAR) Studies on New 4-Aminoquinoline-Hydrazones and Isatin Hybrids as Promising Antibacterial Agents. Molecules, 29(23), 5777. [[Link](#)]
- Okuda, T., et al. (1984). **Penitricin**, a new class of antibiotic produced by *Penicillium aculeatum*. I. Taxonomy of the producer strain and fermentation. The Journal of Antibiotics,

37(7), 712-717. [\[Link\]](#)

- Biology Discussion. (2016, September 16). Penicillins: Discovery and Structure | Antibiotics. [\[Link\]](#)
- Fereja, M. H., et al. (2010). Design and Synthesis of Anti-MRSA Benzimidazolylbenzenesulfonamides. QSAR Studies for Prediction of Antibacterial Activity. *Molecules*, 16(1), 154-171. [\[Link\]](#)
- Armando Hasudungan. (2024, September 11). Penicillin antibiotics - Mechanism of action, side effects and resistance [Video]. YouTube. [\[Link\]](#)
- Todd, D., Cornell, R. J., Wester, R. T., & Wittstruck, T. (1969). The synthesis of analogues of penicillin. Part II. *Journal of the Chemical Society C: Organic*, 408. [\[Link\]](#)
- Okuda, T., & Furumai, T. (1985). **Penitricin**, a new class of antibiotic produced by *Penicillium aculeatum*. IV. Biosynthesis. *The Journal of Antibiotics*, 38(5), 631-635. [\[Link\]](#)
- CrashCourse. (2022, April 14). Medicinal Chemistry and Penicillin Total Synthesis: Crash Course Organic Chemistry #50 [Video]. YouTube. [\[Link\]](#)
- Hansch, C., & Deutsch, E. W. (1965). The Structure-Activity Relationship in Penicillins. *Journal of Medicinal Chemistry*, 8(5), 705-706. [\[Link\]](#)
- Fleming, G. T., et al. (2021). The convergent total synthesis and antibacterial profile of the natural product streptothricin F. *Chemical Science*, 12(3), 1143-1148. [\[Link\]](#)

Need Custom Synthesis?

BenchChem offers custom synthesis for rare earth carbides and specific isotopic labeling.

Email: info@benchchem.com or [Request Quote Online](#).

Sources

- 1. [Penitricin, a new class of antibiotic produced by *Penicillium aculeatum*. III. Structural confirmation by chemical synthesis and biological activity - PubMed](#) [pubmed.ncbi.nlm.nih.gov]

- [2. semanticscholar.org \[semanticscholar.org\]](https://www.semanticscholar.org)
- [3. Penitricin, a new class of antibiotic produced by Penicillium aculeatum. I. Taxonomy of the producer strain and fermentation - PubMed \[pubmed.ncbi.nlm.nih.gov\]](https://pubmed.ncbi.nlm.nih.gov/)
- [4. Synthesis and biological activities of cyclopropenone antibiotic penitricin and congeners - PubMed \[pubmed.ncbi.nlm.nih.gov\]](https://pubmed.ncbi.nlm.nih.gov/)
- [5. Explain the structure activity relationship by giving examples with penic.. \[askfilo.com\]](https://askfilo.com)
- [6. Structure-Activity Relationship \(SAR\) Studies | Oncodesign Services \[oncodesign-services.com\]](https://oncodesign-services.com)
- [7. SYNTHESIS AND BIOLOGICAL ACTIVITIES OF CYCLOPROPENONE ANTIBIOTIC PENITRICIN AND CONGENERS \[jstage.jst.go.jp\]](https://jstage.jst.go.jp)
- [8. walshmedicalmedia.com \[walshmedicalmedia.com\]](https://walshmedicalmedia.com)
- [9. admin.mantechpublications.com \[admin.mantechpublications.com\]](https://admin.mantechpublications.com)
- [10. Interpreting quantitative structure-activity relationship models to guide drug discovery - American Chemical Society \[acs.digitellinc.com\]](https://acs.digitellinc.com)
- [11. researchgate.net \[researchgate.net\]](https://researchgate.net)
- [12. MTT Assay Protocol for Cell Viability and Proliferation \[merckmillipore.com\]](https://merckmillipore.com)
- [13. cyrusbio.com.tw \[cyrusbio.com.tw\]](https://cyrusbio.com.tw)
- [14. Cytotoxicity MTT Assay Protocols and Methods | Springer Nature Experiments \[experiments.springernature.com\]](https://experiments.springernature.com)
- [15. Ex Vivo Red Blood Cell Hemolysis Assay for the Evaluation of pH-responsive Endosomolytic Agents for Cytosolic Delivery of Biomacromolecular Drugs - PMC \[pmc.ncbi.nlm.nih.gov\]](https://pmc.ncbi.nlm.nih.gov/)
- [16. Hemolysis | Cyprotex ADME-Tox Solutions - Evotec \[evotec.com\]](https://evotec.com)
- [17. pdf.benchchem.com \[pdf.benchchem.com\]](https://pdf.benchchem.com)
- To cite this document: BenchChem. [Application Notes & Protocols: A Strategic Guide to Penitricin Structure-Activity Relationship (SAR) Studies]. BenchChem, [2026]. [Online PDF]. Available at: [<https://www.benchchem.com/product/b1219807/docs#application-notes-protocols-a-strategic-guide-to-penitricin-structure-activity-relationship-sar-studies>]

Disclaimer & Data Validity:

The information provided in this document is for Research Use Only (RUO) and is strictly not intended for diagnostic or therapeutic procedures. While BenchChem strives to provide

accurate protocols, we make no warranties, express or implied, regarding the fitness of this product for every specific experimental setup.

Technical Support: The protocols provided are for reference purposes. Unsure if this reagent suits your experiment?

Need Industrial/Bulk Grade? [Request Custom Synthesis Quote](#)

BenchChem

Our mission is to be the trusted global source of essential and advanced chemicals, empowering scientists and researchers to drive progress in science and industry.

Contact

Address: 3281 E Guasti Rd

Ontario, CA 91761, United States

Phone: (601) 213-4426

Email: info@benchchem.com

[Contact our Ph.D. Support Team for a compatibility check](#)