

Tellurophene-Based OFETs Emerge as a Promising Alternative to Pentacene in Organic Electronics

Author: BenchChem Technical Support Team. **Date:** December 2025

Compound of Interest

Compound Name: *Tellurophene*

Cat. No.: *B1218086*

[Get Quote](#)

Researchers and scientists in the field of organic electronics now have compelling evidence positioning **tellurophene**-based Organic Field-Effect Transistors (OFETs) as a high-performance alternative to the widely-used pentacene-based devices. Recent studies highlight that **tellurophene** derivatives, particularly dithieno[3,2-b:2',3'-d]thiophene (DTT), can exhibit charge carrier mobilities and on/off ratios that meet and even exceed those of traditional pentacene OFETs, opening new avenues for the development of next-generation flexible and transparent electronics.

Organic Field-Effect Transistors are fundamental components in a variety of applications, including flexible displays, wearable sensors, and RFID tags. For years, pentacene has been a benchmark material for the active semiconductor layer in these devices due to its reliable performance. However, the exploration of novel organic materials has led to the investigation of **tellurophene**-containing compounds, which are now demonstrating significant potential.

Performance Benchmark: Tellurophene vs. Pentacene

A comparative analysis of key performance metrics reveals the competitive standing of **tellurophene**-based OFETs. The charge carrier mobility (μ), which dictates the switching speed of the transistor, the on/off current ratio (I_{on}/I_{off}), a measure of the device's switching efficiency,

and the threshold voltage (V_{th}), the voltage required to turn the transistor on, are critical parameters for evaluating OFET performance.

Performance Metric	Tellurophene-Based OFETs (DTT derivatives)	Pentacene-Based OFETs
Hole Mobility (μ)	0.07 - 1.26 cm^2/Vs	$\sim 0.5 - 0.75 \text{ cm}^2/\text{Vs}$
On/Off Ratio (I_{on}/I_{off})	$> 10^5 - 10^8$	$\sim 5 \times 10^6$
Threshold Voltage (V_{th})	Varies with device architecture and processing	Varies with device architecture and processing

The data indicates that DTT-based OFETs can achieve significantly higher hole mobilities compared to pentacene. The on/off ratios are also comparable and can reach very high values, ensuring low power consumption in the off state. While the threshold voltage is highly dependent on the specific device fabrication, both materials can be engineered to exhibit suitable switching characteristics.

Experimental Protocols: Fabrication and Characterization

The performance of OFETs is intrinsically linked to the fabrication process of the thin-film active layer. Both **tellurophene**-based and pentacene-based OFETs can be fabricated using solution-processing techniques, which are advantageous for large-area and low-cost manufacturing, as well as vacuum deposition methods that offer high purity and ordered molecular packing.

Solution-Processed OFET Fabrication (Spin-Coating)

A common method for depositing the organic semiconductor from solution is spin-coating. The general procedure is as follows:

- **Substrate Preparation:** A substrate, typically a silicon wafer with a silicon dioxide (SiO_2) dielectric layer, is cleaned using a sequence of solvents (e.g., acetone, isopropanol) in an ultrasonic bath.

- **Surface Treatment:** To improve the quality of the semiconductor film, the dielectric surface is often treated with a self-assembled monolayer (SAM), such as hexamethyldisilazane (HMDS), to make it more hydrophobic.
- **Semiconductor Deposition:** A solution of the organic semiconductor (either a **tellurophene** derivative or a soluble pentacene precursor) in an appropriate organic solvent is dispensed onto the substrate. The substrate is then rotated at a high speed to spread the solution evenly and evaporate the solvent, leaving a thin film of the semiconductor.
- **Annealing:** The substrate is often heated (annealed) to improve the crystallinity and morphology of the organic semiconductor film.
- **Electrode Deposition:** Source and drain electrodes (typically gold) are then deposited on top of the semiconductor layer through a shadow mask using thermal evaporation.

Vacuum-Deposited OFET Fabrication (Thermal Evaporation)

For materials with lower solubility, thermal evaporation under high vacuum is the preferred method:

- **Substrate Preparation:** Similar to the solution-processing method, the substrate is thoroughly cleaned.
- **Source and Drain Electrode Patterning:** For a bottom-contact architecture, the source and drain electrodes are first patterned on the dielectric layer.
- **Semiconductor Deposition:** The organic semiconductor (e.g., pentacene) is placed in a crucible inside a vacuum chamber. The material is heated until it sublimates, and the vapor deposits as a thin film onto the cooled substrate. The thickness of the film is monitored in real-time using a quartz crystal microbalance.
- **Device Completion:** For a top-contact architecture, the semiconductor is deposited first, followed by the thermal evaporation of the source and drain electrodes through a shadow mask.

Characterization of OFETs

The electrical characteristics of the fabricated OFETs are measured using a semiconductor parameter analyzer in a probe station. The key parameters are extracted from the output and transfer characteristics of the device.

- Charge Carrier Mobility (μ): Calculated from the slope of the transfer curve (drain current vs. gate voltage) in the saturation regime.
- On/Off Ratio (I_{on}/I_{off}): The ratio of the maximum drain current (on-state) to the minimum drain current (off-state) from the transfer curve.
- Threshold Voltage (V_{th}): Determined by extrapolating the linear portion of the transfer curve to the gate voltage axis.

Logical Workflow for OFET Comparison

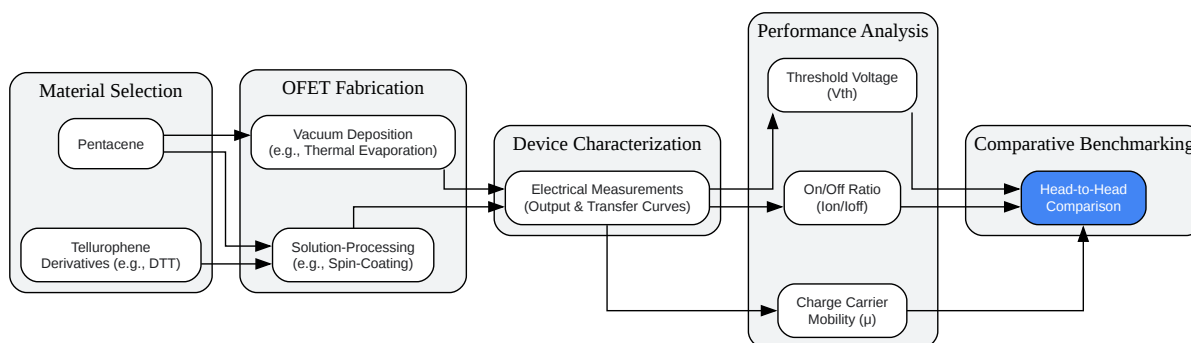

[Click to download full resolution via product page](#)

Figure 1. Logical workflow for benchmarking OFET performance.

The continued development of novel organic semiconductors like **tellurophene** derivatives is crucial for advancing the field of organic electronics. The impressive performance metrics of these new materials, coupled with the versatility of fabrication techniques, suggest a promising future for more efficient and cost-effective organic electronic devices.

- To cite this document: BenchChem. [Tellurophene-Based OFETs Emerge as a Promising Alternative to Pentacene in Organic Electronics]. BenchChem, [2025]. [Online PDF]. Available at: [<https://www.benchchem.com/product/b1218086#benchmarking-the-performance-of-tellurophene-based-ofets-against-pentacene>]

Disclaimer & Data Validity:

The information provided in this document is for Research Use Only (RUO) and is strictly not intended for diagnostic or therapeutic procedures. While BenchChem strives to provide accurate protocols, we make no warranties, express or implied, regarding the fitness of this product for every specific experimental setup.

Technical Support: The protocols provided are for reference purposes. Unsure if this reagent suits your experiment? [[Contact our Ph.D. Support Team for a compatibility check](#)]

Need Industrial/Bulk Grade? [Request Custom Synthesis Quote](#)

BenchChem

Our mission is to be the trusted global source of essential and advanced chemicals, empowering scientists and researchers to drive progress in science and industry.

Contact

Address: 3281 E Guasti Rd
Ontario, CA 91761, United States
Phone: (601) 213-4426
Email: info@benchchem.com