

Technical Support Center: Dihydroergocryptine Vasoconstriction in Experimental Setups

Author: BenchChem Technical Support Team. **Date:** April 2026

Compound of Interest

Compound Name:	Vasobral
CAS No.:	94423-99-1
Cat. No.:	B1218170

[Get Quote](#)

This technical support center provides researchers, scientists, and drug development professionals with comprehensive guidance on mitigating the vasoconstrictive effects of dihydroergocryptine (DHE) in experimental settings. This resource includes frequently asked questions, troubleshooting guides, quantitative data on mitigating agents, detailed experimental protocols, and visualizations of the underlying signaling pathways.

Frequently Asked Questions (FAQs)

Q1: What is the primary mechanism of dihydroergocryptine-induced vasoconstriction?

A1: Dihydroergocryptine's vasoconstrictive effects are complex and multifactorial, primarily mediated through its interaction with multiple receptor systems. It acts as an agonist or partial agonist at α 1- and α 2-adrenergic receptors and various serotonin (5-HT) receptors, particularly 5-HT1B/1D and 5-HT2A subtypes.[1][2] Activation of these receptors on vascular smooth muscle cells initiates signaling cascades that lead to an increase in intracellular calcium and subsequent muscle contraction.

Q2: Which pharmacological agents are most effective in mitigating DHE-induced vasoconstriction?

A2: The most effective agents are antagonists of the receptors that DHE activates. These include:

- α -Adrenergic Antagonists: Phentolamine (non-selective), prazosin (α 1-selective), and yohimbine or rauwolscine (α 2-selective) can all attenuate DHE's effects.[1][2] The choice of antagonist can help to dissect the relative contribution of α 1 and α 2 receptors in a specific vascular bed.
- Serotonin (5-HT) Antagonists: Ketanserin (5-HT_{2A} antagonist) and GR127935 (5-HT_{1B/1D} antagonist) have been shown to be effective in blocking the serotonergic component of DHE-induced vasoconstriction.[3][4][5]
- Calcium Channel Blockers (CCBs): Dihydropyridine (e.g., nifedipine) and non-dihydropyridine (e.g., verapamil) CCBs can produce vasodilation by inhibiting the influx of extracellular calcium, which is a common downstream step in the vasoconstrictive signaling pathway.

Q3: Can the vasoconstrictive effects of DHE be completely reversed?

A3: In many experimental setups, the vasoconstriction can be significantly attenuated or reversed with the appropriate antagonists. However, complete reversal may depend on the concentration of DHE used, the specific vascular bed being studied, and the timing of antagonist administration. Some studies suggest that ergot alkaloids can exhibit "pseudo-irreversible" binding characteristics, making complete reversal challenging, especially at higher concentrations.

Q4: Are there species-specific differences in the response to DHE?

A4: Yes, the expression and distribution of adrenergic and serotonergic receptor subtypes can vary between species and even between different vascular beds within the same animal. Therefore, the relative contribution of each receptor system to DHE-induced vasoconstriction and the efficacy of specific antagonists may differ. It is crucial to consult literature relevant to the specific animal model and vascular tissue being investigated.

Troubleshooting Guide

Problem	Possible Cause(s)	Recommended Solution(s)
No or weak vasoconstrictive response to DHE	<ol style="list-style-type: none"> 1. DHE solution degradation. 2. Incorrect DHE concentration. 3. Tissue desensitization or damage. 4. Low receptor expression in the chosen vascular bed. 	<ol style="list-style-type: none"> 1. Prepare fresh DHE solutions for each experiment. Protect from light. 2. Verify calculations and perform a concentration-response curve. 3. Ensure gentle handling of the tissue during preparation. Check tissue viability with a standard agonist (e.g., phenylephrine, KCl). 4. Consult literature to confirm receptor expression in your tissue of interest. Consider using a different vascular preparation.
High variability in vasoconstrictive responses between tissues	<ol style="list-style-type: none"> 1. Inconsistent tissue preparation (e.g., differences in ring size, endothelial damage). 2. Variation in animal age, weight, or health status. 3. Inconsistent experimental conditions (e.g., temperature, pH, oxygenation of the buffer). 	<ol style="list-style-type: none"> 1. Standardize the dissection and mounting procedures. Verify endothelial integrity or denudation for each tissue ring. 2. Use animals from a consistent source and within a narrow age and weight range. 3. Calibrate and monitor all organ bath parameters throughout the experiment.
Incomplete or slow reversal of vasoconstriction with antagonists	<ol style="list-style-type: none"> 1. DHE concentration is too high, leading to insurmountable antagonism. 2. The chosen antagonist does not target all the relevant receptors. 3. "Pseudo-irreversible" binding of DHE to its receptors. 	<ol style="list-style-type: none"> 1. Perform a DHE concentration-response curve and work with concentrations in the lower to mid-range of the curve (e.g., EC₅₀ to EC₈₀). 2. Consider using a combination of antagonists (e.g., an α-adrenergic blocker plus a 5-HT blocker).^[1] 3. Increase the incubation time with the

antagonist before and after DHE administration.

Unexpected vasodilation at low DHE concentrations

1. Activation of endothelial nitric oxide synthase (eNOS) leading to NO-mediated relaxation. 2. DHE's partial agonist/antagonist activity at certain receptors.

1. Test the response in endothelium-denuded preparations to assess the role of the endothelium. 2. This can be a characteristic of the drug's pharmacology. Carefully document the biphasic response.

Quantitative Data Summary: Antagonists for DHE-Induced Vasoconstriction

The following table summarizes the potency of various antagonists in mitigating the effects of dihydroergotamine (a close analog of dihydroergocryptine). The pA₂ value is the negative logarithm of the molar concentration of an antagonist that produces a two-fold shift to the right in an agonist's concentration-response curve. Higher pA₂ values indicate greater antagonist potency.

Antagonist	Target Receptor(s)	Experimental Model	pA2 Value	Reference
Prazosin	α 1-adrenergic	Pithed Rat (ritanserin pre-treated)	-	[1]
Rauwolscine	α 2-adrenergic	Porcine Pulmonary Artery	7.24	[6]
Yohimbine	α 2-adrenergic	Pithed Rat	-	[2]
Pizotifen	5-HT1/2	Porcine Pulmonary Artery	8.23	[6]
GR127935	5-HT1B/1D	Bovine Middle Cerebral Artery	8.1 (vs. sumatriptan)	[3]
Ketanserin	5-HT2A	Rat Perfused Mesentery	7.5 (vs. noradrenaline)	[5]

Note: Direct pA2 values for all antagonists against dihydroergocryptine in a single system are not readily available in the literature. The data presented are from various studies and experimental conditions and should be used as a comparative guide.

Experimental Protocols

Isolated Rat Aortic Ring Assay for Vasoconstriction

This protocol describes a standard ex vivo method to assess the vasoconstrictive properties of dihydroergocryptine and the efficacy of mitigating agents.

1. Materials and Reagents:

- Male Wistar rats (250-300g)
- Krebs-Henseleit buffer (in mM: NaCl 118, KCl 4.7, CaCl₂ 2.5, KH₂PO₄ 1.2, MgSO₄ 1.2, NaHCO₃ 25, glucose 11.1)
- Phenylephrine (PE)

- Acetylcholine (ACh)
- Dihydroergocryptine (DHE)
- Antagonist of choice (e.g., phentolamine, ketanserin)
- Distilled water
- Carbogen gas (95% O₂, 5% CO₂)
- Organ bath system with isometric force transducers

2. Aortic Ring Preparation:

- Euthanize the rat via an approved method.
- Perform a midline laparotomy and thoracotomy to expose the thoracic aorta.
- Carefully dissect the thoracic aorta and place it in a petri dish filled with ice-cold Krebs-Henseleit buffer.
- Remove adhering fat and connective tissue.
- Cut the aorta into rings of 3-4 mm in length.
- (Optional) For endothelium-denuded preparations, gently rub the luminal surface of the aortic ring with a fine wire or wooden stick.

3. Experimental Setup:

- Mount each aortic ring between two L-shaped stainless-steel hooks in an organ bath chamber containing 10 mL of Krebs-Henseleit buffer, continuously gassed with carbogen and maintained at 37°C.
- Connect the upper hook to an isometric force transducer to record changes in tension.
- Allow the rings to equilibrate for 60-90 minutes under a resting tension of 1.5-2.0 g. Replace the buffer every 15-20 minutes.

4. Viability and Endothelial Integrity Check:

- After equilibration, contract the rings by adding 60 mM KCl to the bath. After the contraction plateaus, wash the rings with fresh buffer until the tension returns to baseline.
- Induce a submaximal contraction with phenylephrine (e.g., 1 μ M).
- Once the PE-induced contraction is stable, add acetylcholine (e.g., 10 μ M). A relaxation of >80% indicates intact endothelium. A relaxation of <10% confirms successful denudation.
- Wash the rings and allow them to return to baseline.

5. Investigating DHE and Mitigation:

- DHE Concentration-Response: Add cumulative concentrations of DHE to the organ bath and record the contractile response at each concentration until a maximal response is achieved.
- Antagonist Protocol:
 - After the initial washout, incubate the aortic rings with the chosen antagonist (e.g., phentolamine 1 μ M) for 20-30 minutes.
 - In the continued presence of the antagonist, repeat the cumulative addition of DHE and record the concentration-response curve.
 - A rightward shift in the DHE concentration-response curve indicates competitive antagonism.

6. Data Analysis:

- Express the contractile responses as a percentage of the maximal contraction induced by KCl.
- Plot the concentration-response curves using a logarithmic scale for the agonist concentration.
- Calculate the EC₅₀ (half-maximal effective concentration) values for DHE in the absence and presence of the antagonist.

Signaling Pathways and Mechanisms of Mitigation

Dihydroergocryptine-induced vasoconstriction is initiated by its binding to α -adrenergic and serotonin receptors on vascular smooth muscle cells. The primary signaling pathways are depicted below.

DHE-Induced Vasoconstriction Pathways

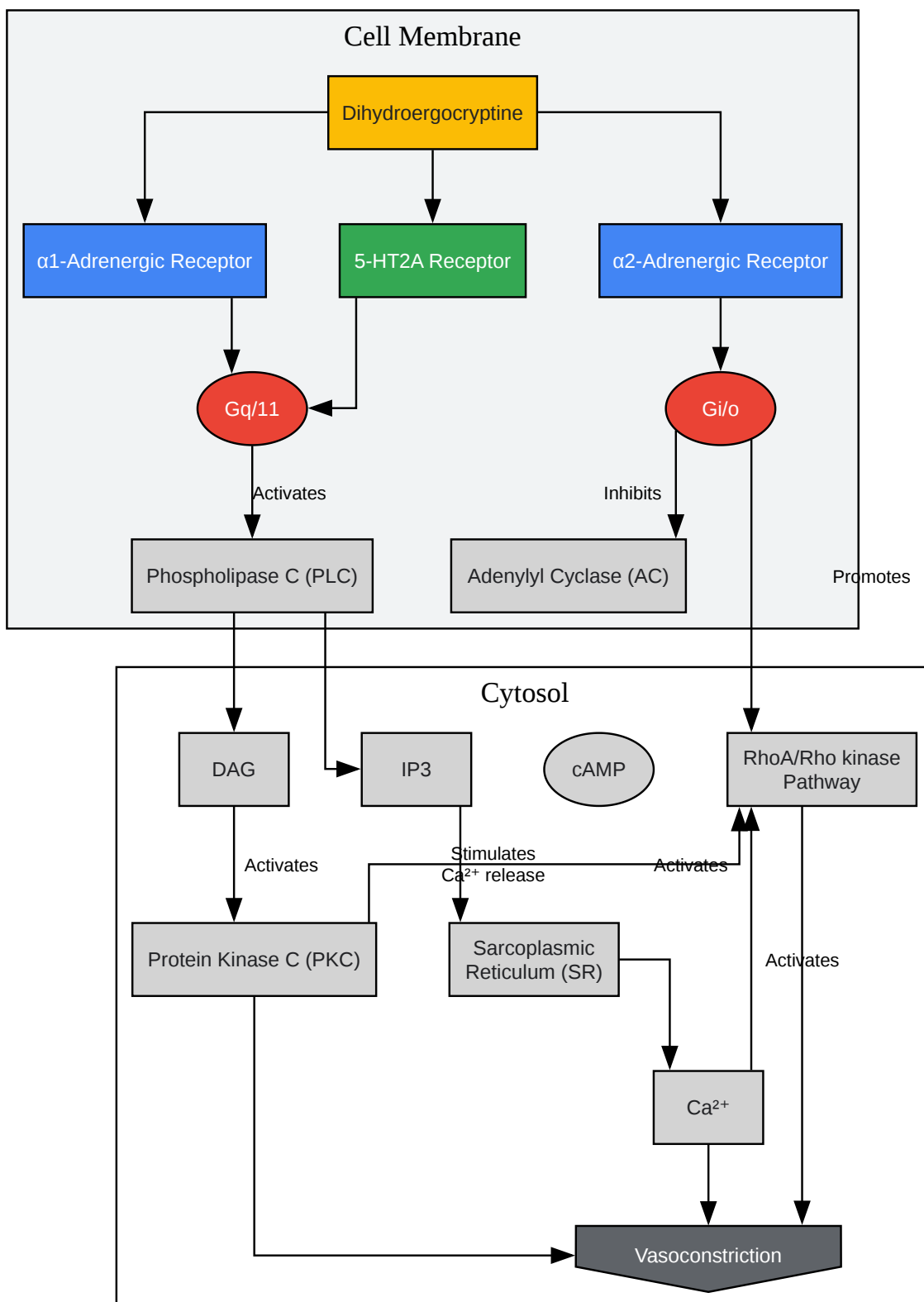

[Click to download full resolution via product page](#)

Caption: Signaling pathways of DHE-induced vasoconstriction.

Experimental Workflow for Mitigation Studies

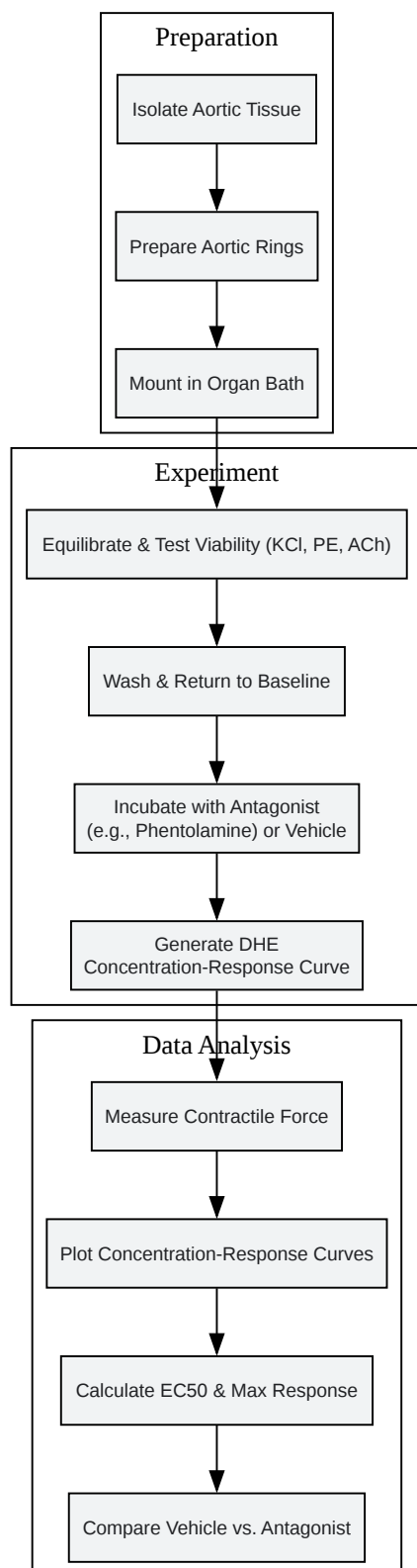

[Click to download full resolution via product page](#)

Caption: Workflow for studying mitigation of DHE vasoconstriction.

Points of Intervention for Mitigating Agents

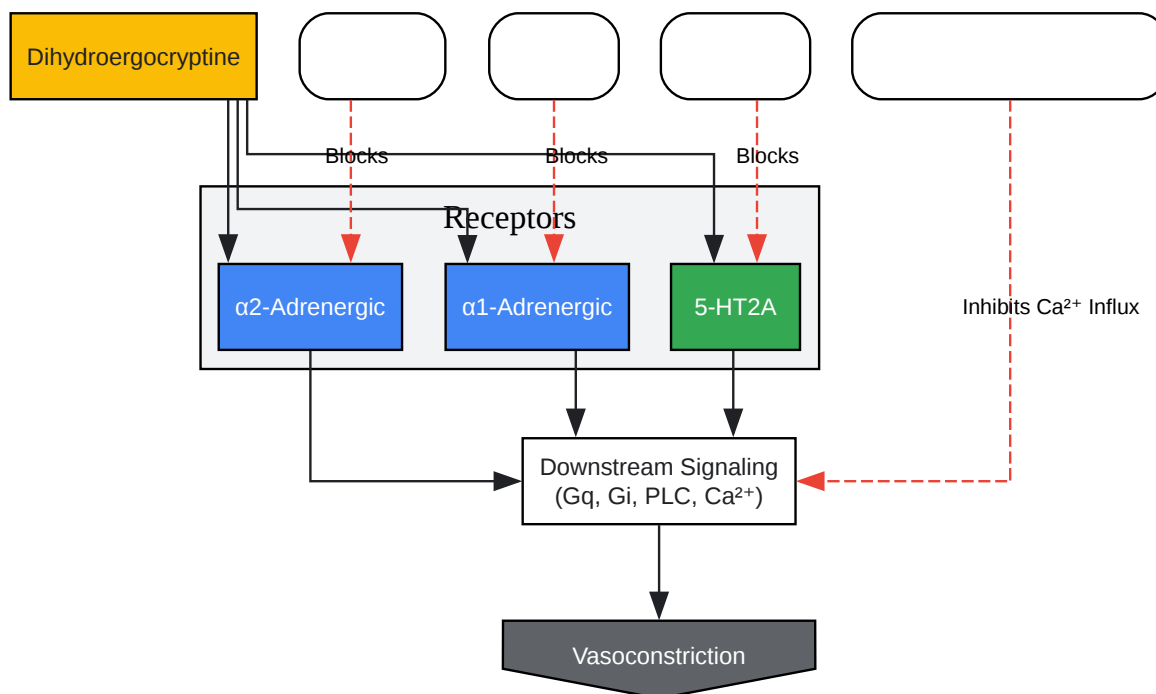

[Click to download full resolution via product page](#)

Caption: Intervention points for mitigating DHE vasoconstriction.

Need Custom Synthesis?

BenchChem offers custom synthesis for rare earth carbides and specific isotopic labeling.

Email: info@benchchem.com or [Request Quote Online](#).

References

- 1. repub.eur.nl [repub.eur.nl]

- [2. The role of \$\alpha\$ 1- and \$\alpha\$ 2-adrenoceptor subtypes in the vasopressor responses induced by dihydroergotamine in ritanserin-pretreated pithed rats - PMC \[pmc.ncbi.nlm.nih.gov\]](#)
- [3. Bovine isolated middle cerebral artery contractions to antimigraine drugs - PubMed \[pubmed.ncbi.nlm.nih.gov\]](#)
- [4. The use of ketanserin, a 5-hydroxytryptamine receptor antagonist, for treatment of postoperative hypertension following coronary artery bypass surgery - PubMed \[pubmed.ncbi.nlm.nih.gov\]](#)
- [5. Antagonism by ketanserin of 5-HT-induced vasoconstriction unmasks a 5-HT-induced vasodilation - PubMed \[pubmed.ncbi.nlm.nih.gov\]](#)
- [6. Endothelial 5-HT receptors mediate relaxation of porcine pulmonary arteries in response to ergotamine and dihydroergotamine - PubMed \[pubmed.ncbi.nlm.nih.gov\]](#)
- [To cite this document: BenchChem. \[Technical Support Center: Dihydroergocryptine Vasoconstriction in Experimental Setups\]. BenchChem, \[2026\]. \[Online PDF\]. Available at: \[https://www.benchchem.com/product/b1218170/docs#technical-support-center-dihydroergocryptine-vasoconstriction-in-experimental-setups\]](#)

Disclaimer & Data Validity:

The information provided in this document is for Research Use Only (RUO) and is strictly not intended for diagnostic or therapeutic procedures. While BenchChem strives to provide accurate protocols, we make no warranties, express or implied, regarding the fitness of this product for every specific experimental setup.

Technical Support: The protocols provided are for reference purposes. Unsure if this reagent suits your experiment?

Need Industrial/Bulk Grade? [Request Custom Synthesis Quote](#)

BenchChem

Our mission is to be the trusted global source of essential and advanced chemicals, empowering scientists and researchers to drive progress in science and industry.

Contact

Address: 3281 E Guasti Rd
Ontario, CA 91761, United States
Phone: (601) 213-4426
Email: info@benchchem.com

Contact our Ph.D. Support Team for a compatibility check