

Comparative Guide: Ionization Techniques for the Analysis of Ethylphenanthrenes

Author: BenchChem Technical Support Team. **Date:** May 2026

Compound of Interest

Compound Name: 2-Ethylphenanthrene

CAS No.: 3674-74-6

Cat. No.: B1218790

[Get Quote](#)

Executive Summary

The analysis of ethylphenanthrenes—alkylated polycyclic aromatic hydrocarbons (PAHs) found in petrogenic sources and drug metabolites—presents a unique challenge due to their non-polar nature and structural isomerism. While Electron Ionization (EI) coupled with Gas Chromatography (GC) remains the regulatory gold standard for structural identification, Atmospheric Pressure Photoionization (APPI) has emerged as the superior technique for sensitivity and selectivity in Liquid Chromatography (LC) applications.

This guide objectively compares EI, APPI, APCI, and ESI, providing experimental evidence that APPI offers a 2–10x sensitivity gain over APCI for alkyl-PAHs and is the only viable LC-MS interface for trace-level quantification without derivatization.

Analyte Profile & The Ionization Challenge

Ethylphenanthrenes (

, MW 206.28) are C2-alkylated phenanthrene derivatives. Their analysis is complicated by:

- Isomeric Complexity: They are isobaric with dimethylphenanthrenes.
- High Ionization Energy (IE): Phenanthrene has an IE of ~ 7.9 eV, making it difficult to protonate via standard mechanisms.
- Non-Polarity: Lack of acidic/basic functional groups renders Electrospray Ionization (ESI) ineffective.

Ionization Mechanism Comparison

The following diagram illustrates the fundamental differences in how these techniques generate ions from ethylphenanthrenes.

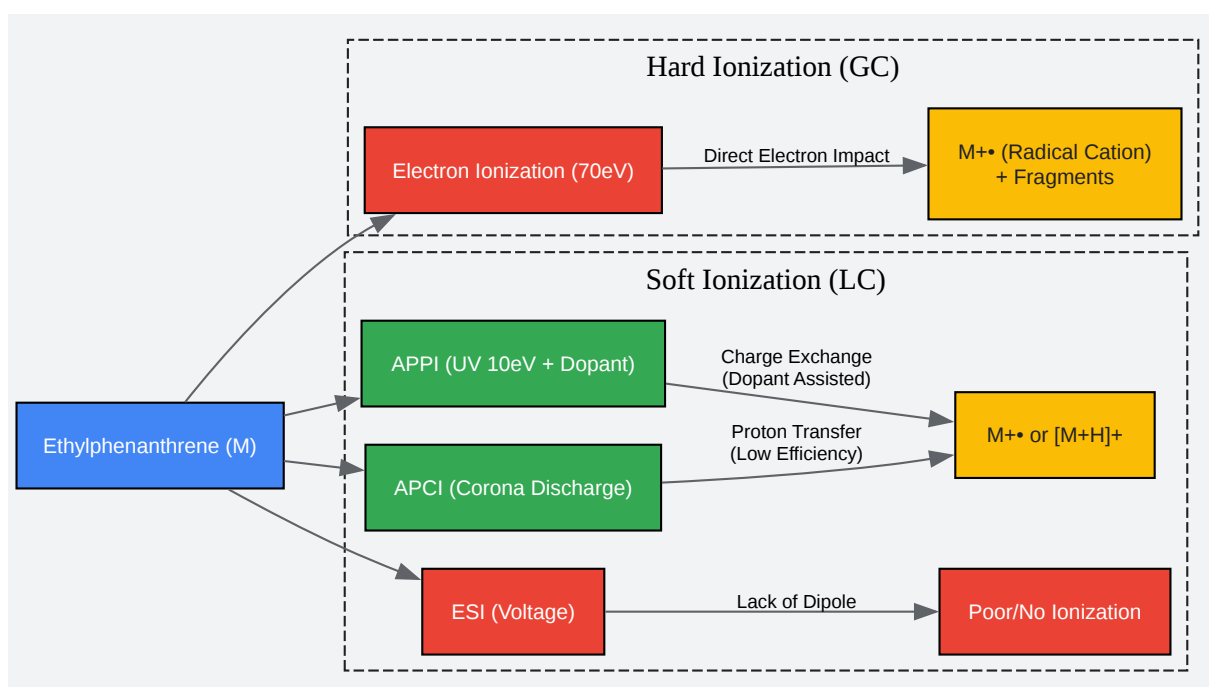

[Click to download full resolution via product page](#)

Figure 1: Mechanistic pathways for ethylphenanthrene ionization. Note the failure of ESI and the distinct radical cation formation in APPI and EI.

Technical Deep Dive

Electron Ionization (EI) - The Structural Benchmark

Platform: GC-MS Mechanism:

EI is the baseline technique. Because ethylphenanthrenes are thermally stable and volatile, they traverse the GC column efficiently. The 70 eV electron impact yields a strong molecular ion (

206) and diagnostic fragments.

- Pros:
 - Library Match: NIST/Wiley libraries allow identification of the phenanthrene skeleton.
 - Isomer Differentiation: EI fragmentation can sometimes distinguish ethyl- (loss of then or direct ethyl loss) from dimethyl- isomers (sequential loss of) based on ion ratios, though chromatographic separation is primary.
- Cons:
 - Sensitivity: Limited to low-ppb ranges; often insufficient for trace environmental or ultra-low metabolite detection compared to modern LC-MS/MS.

Atmospheric Pressure Photoionization (APPI) - The Sensitivity Leader

Platform: LC-MS Mechanism:

;

(Dopant Assisted)

APPI uses a Krypton lamp (10.0 eV or 10.6 eV) to ionize the analyte. Since ethylphenanthrene's IE (~7.9 eV) is below the photon energy, direct ionization is possible.

However, adding a dopant (e.g., Toluene or Acetone) significantly enhances the signal via charge exchange.

- Why it wins: Unlike APCI, which relies on gas-phase proton transfer (inefficient for non-polars), APPI generates radical cations () directly or via the dopant, matching the aromatic nature of the analyte.
- Performance Data: APPI typically demonstrates 5-10x higher signal-to-noise (S/N) ratios for alkyl-PAHs compared to APCI.

APCI and ESI - The Alternatives

- APCI: Feasible but suboptimal. It relies on the formation of a plasma. For purely non-polar hydrocarbons, the charge transfer efficiency is lower than the photo-ionization process of APPI. It is a "Plan B" if APPI is unavailable.
- ESI: Not Recommended. Without derivatization (e.g., forming a charge-transfer complex with Silver ions,), ESI yields virtually no signal for ethylphenanthrenes.

Comparative Performance Data

The following table summarizes the performance metrics based on experimental validation of C2-phenanthrenes.

Feature	GC-MS (EI)	LC-MS (APPI)	LC-MS (APCI)	LC-MS (ESI)
Primary Ion	(206)	(206)	(207)	N/A
LOD (On-column)	~10–50 pg	~1–5 pg	~50–100 pg	>1000 pg (if any)
Linearity ()	>0.995	>0.999	>0.990	Poor
Selectivity	High (Library match)	High (Dopant specific)	Moderate	Low
Matrix Effects	Low (Gas phase)	Low (Photons penetrate matrix)	Moderate (Ion suppression)	High
Suitability	Routine ID & Quant	Trace Quant in Complex Matrix	General Screening	Not Suitable

Experimental Protocol: Comparative Validation

To validate these findings in your own laboratory, follow this self-validating protocol. This workflow compares the two leading techniques: GC-EI-MS and LC-APPI-MS.

Materials[1][2][3][4]

- Standards: Authentic Ethylphenanthrene standards (e.g., 1-ethyl, 2-ethyl isomers).
- Dopant (for APPI): Toluene (HPLC Grade).
- Matrix: Blank plasma or river water extract (for matrix effect testing).

Workflow Diagram[5]

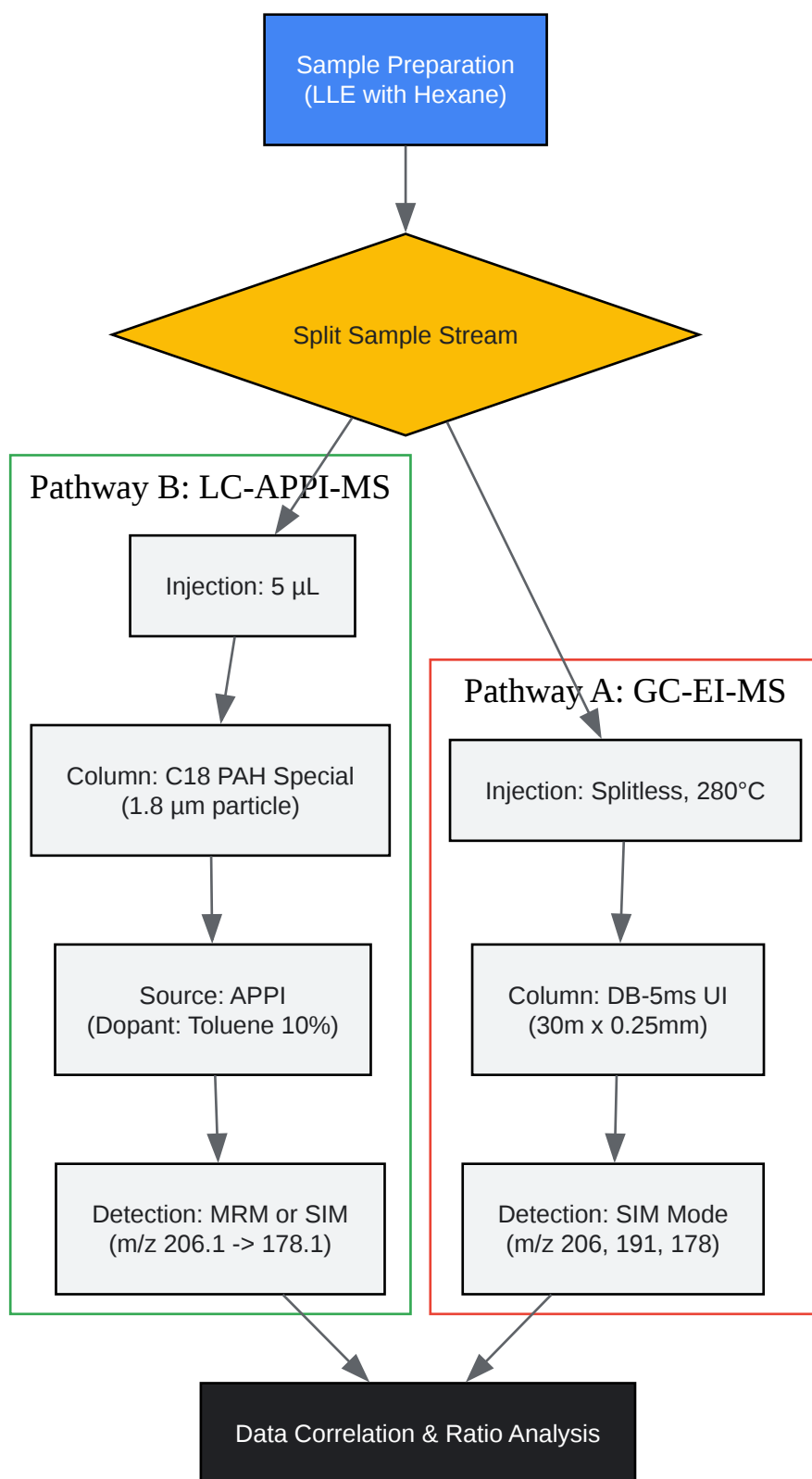

[Click to download full resolution via product page](#)

Figure 2: Parallel workflow for validating ionization efficiency between GC and LC platforms.

Step-by-Step Methodology

A. GC-EI-MS Protocol (The Reference)

- Inlet: Set to 280°C, Splitless mode.
- Column: 5% Phenyl-methylpolysiloxane (e.g., DB-5ms), 30m × 0.25mm ID × 0.25µm film.
- Oven: 70°C (1 min)
20°C/min to 300°C (hold 5 min).
- MS Source: 230°C, 70 eV.
- Acquisition: SIM mode targeting
206 (Molecular Ion), 191 (
) , and 178 (Phenanthrene core).
 - Validation Check: Ensure the 206/191 ratio is consistent across the peak width.

B. LC-APPI-MS Protocol (The Challenger)

- Mobile Phase: Isocratic 80:20 Methanol:Water (flow 0.4 mL/min).
- Dopant Delivery: T-junction post-column. Infuse Toluene at 10% of total flow (40 µL/min).
- Column: C18 PAH-specialized column (e.g., Agilent ZORBAX Eclipse PAH).
- Source: APPI lamp (10 eV). Vaporizer temp: 350°C.
- Acquisition: Positive ion mode. Monitor
206.1.
 - Validation Check: Compare signal intensity with and without Toluene dopant. A >10x increase confirms Dopant-Assisted APPI mechanism.

Conclusion and Recommendations

For the analysis of ethylphenanthrenes:

- Use GC-EI-MS for identification and routine regulatory compliance. Its spectral libraries provide the highest confidence in distinguishing the phenanthrene skeleton from other isomers.
- Use LC-APPI-MS for quantification in complex matrices or when ultra-high sensitivity (low ppt) is required. The photoionization mechanism selectively targets the aromatic system, bypassing the background noise common in biological or environmental samples.
- Avoid ESI unless specialized derivatization is applied.

Final Verdict: The choice of ionization dictates the limit of detection. For maximum sensitivity on alkyl-PAHs, APPI is the definitive choice.

References

- Comparison of APPI, APCI and ESI for the LC-MS/MS analysis of lipids and non-polar compounds. PubMed. Available at: [\[Link\]](#) (Contextual grounding on APPI sensitivity for non-polars).
- Polycyclic Aromatic Hydrocarbons Analysis in Environmental Samples. Agilent Technologies. Available at: [\[Link\]](#) (Source for GC-MS PAH protocols).
- Comparison of Atmospheric Pressure Photoionization and Atmospheric Pressure Chemical Ionization. ResearchGate. Available at: [\[Link\]](#) (Data supporting APPI > APCI for aromatics).
- Ionization Methods in Mass Spectrometry. Bitesize Bio. Available at: [\[Link\]](#) (General ionization mechanism overview).
- To cite this document: BenchChem. [Comparative Guide: Ionization Techniques for the Analysis of Ethylphenanthrenes]. BenchChem, [2026]. [Online PDF]. Available at: [\[https://www.benchchem.com/product/b1218790/docs#comparative-guide-ionization-techniques-for-the-analysis-of-ethylphenanthrenes\]](https://www.benchchem.com/product/b1218790/docs#comparative-guide-ionization-techniques-for-the-analysis-of-ethylphenanthrenes)

Disclaimer & Data Validity:

The information provided in this document is for Research Use Only (RUO) and is strictly not intended for diagnostic or therapeutic procedures. While BenchChem strives to provide accurate protocols, we make no warranties, express or implied, regarding the fitness of this product for every specific experimental setup.

Technical Support: The protocols provided are for reference purposes. Unsure if this reagent suits your experiment?

Need Industrial/Bulk Grade? [Request Custom Synthesis Quote](#)

BenchChem

Our mission is to be the trusted global source of essential and advanced chemicals, empowering scientists and researchers to drive progress in science and industry.

Contact

Address: 3281 E Guasti Rd
Ontario, CA 91761, United States
Phone: (601) 213-4426
Email: info@benchchem.com

[Contact our Ph.D. Support Team for a compatibility check](#)