

# A Comparative Guide to Nuclear Counterstaining: Proflavine Sulfate vs. DAPI

**Author:** BenchChem Technical Support Team. **Date:** May 2026

## Compound of Interest

Compound Name: Proflavine Sulfate

CAS No.: 553-30-0

Cat. No.: B1218852

[Get Quote](#)

For Researchers, Scientists, and Drug Development Professionals

In the landscape of cellular imaging, the precise visualization of the nucleus is fundamental. Nuclear counterstains are therefore indispensable tools, providing essential context for the localization of proteins, RNAs, and other subcellular structures. For decades, 4',6-diamidino-2-phenylindole, or DAPI, has been the go-to blue fluorescent nuclear stain. However, the expanding palette of fluorophores and the increasing complexity of multiplex imaging experiments necessitate a broader consideration of available reagents. This guide provides an in-depth, objective comparison of the classic intercalating agent, **proflavine sulfate**, and the well-established minor groove binder, DAPI, for nuclear counterstaining applications.

## At the Bench: A Tale of Two Dyes

The choice between **proflavine sulfate** and DAPI extends beyond their distinct emission colors. Their fundamental mechanisms of DNA binding dictate their performance characteristics, influencing everything from staining protocols to photostability and potential cytotoxicity. Understanding these differences is paramount for designing robust and reproducible imaging experiments.

## The Intercalator: Proflavine Sulfate

Proflavine is an acridine derivative that inserts itself, or intercalates, between adjacent base pairs of the DNA double helix.[1] This forces a localized unwinding of the DNA, a mechanism that underpins its historical use as an antiseptic and its known mutagenic properties.[2][3] For imaging, this intercalation results in a distinct green fluorescence, offering a spectral alternative to the commonly used blue and red channels.

## The Minor Groove Binder: DAPI

DAPI, in contrast, is a non-intercalating dye that binds to the minor groove of double-stranded DNA, with a strong preference for adenine-thymine (A-T) rich regions.[4][5] This interaction is less disruptive to the overall DNA structure compared to intercalation. Upon binding, DAPI's fluorescence quantum yield increases approximately 20-fold, resulting in a bright blue fluorescence that is a mainstay in microscopy laboratories worldwide.[6][7]

## Head-to-Head Comparison: Proflavine Sulfate vs. DAPI

Feature	Proflavine Sulfate	DAPI (4',6-diamidino-2-phenylindole)
Fluorescence Color	Green	Blue
Excitation Max (bound to dsDNA)	~444 nm[8]	~358 nm[5]
Emission Max (bound to dsDNA)	~511 nm[8]	~461 nm[5][9]
Binding Mechanism	Intercalation between DNA base pairs[1][2]	Minor groove binding (A-T rich regions)[4][5]
Cell Permeability	Permeable to live and fixed cells[10][11]	Permeable to fixed cells; limited permeability in live cells, often requiring higher concentrations[12]
Primary Application	Nuclear and cytoplasmic counterstain in fixed and live cells[10]	General nuclear counterstain, primarily in fixed cells; viability marker in some applications
Photostability	Generally considered to have good photostability	Exhibits greater photostability compared to Hoechst dyes[5] but can undergo photoconversion to green and red emitting forms with prolonged UV exposure[12]
Cytotoxicity	Known mutagen and possesses cytotoxic properties[2][3]	Can be toxic to live cells, especially at higher concentrations and with prolonged exposure[12]
Compatibility	Spectrally distinct from blue and far-red fluorophores	Ideal for use with green and red fluorophores with minimal spectral overlap

## Delving Deeper: Mechanistic Insights and Practical Implications

The choice between an intercalator and a minor groove binder is not merely academic; it has direct consequences for experimental design and data interpretation.

### Mechanism of Action: A Visual Explanation

The distinct binding modes of **proflavine sulfate** and DAPI are visualized below. Proflavine's intercalation physically separates DNA base pairs, while DAPI nestles within the minor groove.

Figure 1. DNA Binding Mechanisms

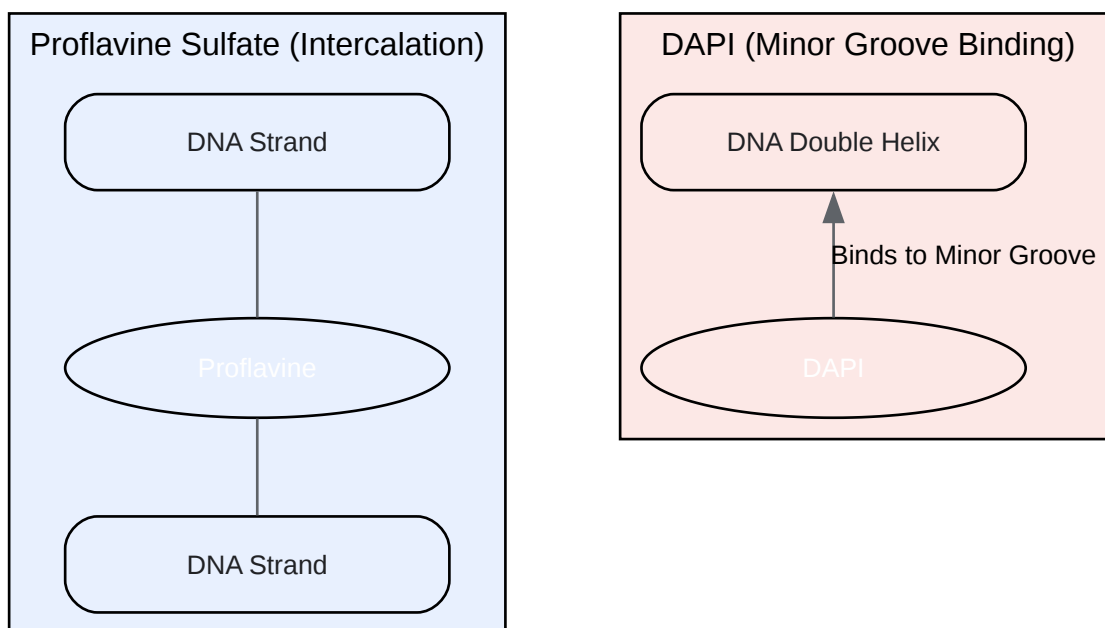
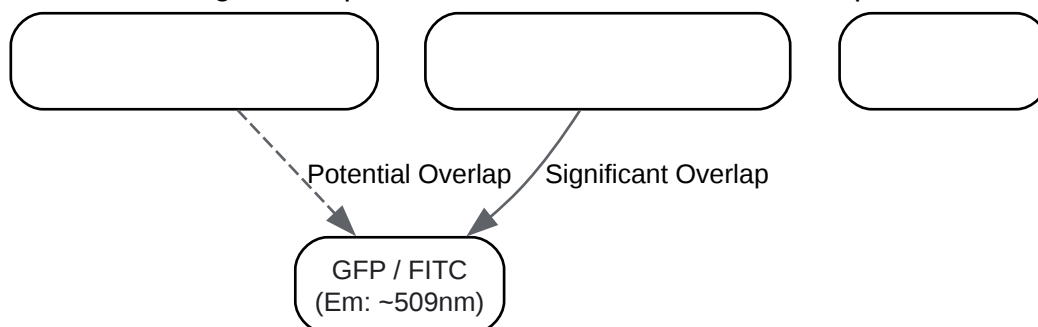

Figure 2. Spectral Profiles and Potential Overlap



[Click to download full resolution via product page](#)

Caption: Spectral profiles and potential overlaps.

## Live-Cell Imaging: A Balancing Act of Permeability and Toxicity

Both **proflavine sulfate** and DAPI can be used for live-cell imaging, but their efficacy and impact on cell health differ. Proflavine's small, amphipathic structure allows it to readily pass through cell and nuclear membranes, enabling rapid staining of live cells without the need for permeabilization. [10][11] However, its intercalating nature and known mutagenicity raise concerns about its use in long-term live-cell imaging experiments. [2][3] DAPI is generally considered less permeable to the membranes of healthy live cells and often requires higher concentrations for effective staining compared to fixed cells. [12][13] While it is often used as a viability marker for this reason, its use in live-cell nuclear staining can be associated with cytotoxicity over time. [12] For long-term live-cell imaging, alternatives like Hoechst 33342, which is more cell-permeant and less toxic than DAPI, are often preferred. [12]

## Experimental Protocols

The following protocols provide a starting point for using **proflavine sulfate** and DAPI for nuclear counterstaining in fixed cells. Optimal concentrations and incubation times may vary depending on the cell type and experimental conditions.

### Proflavine Sulfate Staining Protocol for Fixed Cells

- **Prepare Staining Solution:** Prepare a 0.01% (w/v) **proflavine sulfate** solution in phosphate-buffered saline (PBS). For example, dissolve 1 mg of **proflavine sulfate** in 10 mL of PBS.
- **Fix and Permeabilize Cells:** Grow cells on coverslips. Fix with 4% paraformaldehyde in PBS for 10-15 minutes at room temperature. If required for your primary antibody, permeabilize with 0.1-0.5% Triton X-100 in PBS for 10 minutes.
- **Primary and Secondary Antibody Incubation (for Immunofluorescence):** If performing immunofluorescence, proceed with your standard blocking, primary, and secondary antibody incubation steps.
- **Counterstain with Proflavine Sulfate:** After the final wash following secondary antibody incubation, add the 0.01% **proflavine sulfate** solution to the coverslips and incubate for 5-10

minutes at room temperature, protected from light.

- Wash: Rinse the coverslips two to three times with PBS to remove excess stain.
- Mount: Mount the coverslips onto microscope slides using an appropriate mounting medium.
- Image: Visualize using a fluorescence microscope with filter sets appropriate for green fluorescence (e.g., excitation around 450-490 nm and emission around 500-550 nm).

## DAPI Staining Protocol for Fixed Cells

- Prepare DAPI Stock and Working Solutions: Prepare a stock solution of DAPI (e.g., 1 mg/mL in deionized water or dimethylformamide). This stock solution should be stored at -20°C. From the stock, prepare a working solution of 300 nM in PBS. [6]2. Fix and Permeabilize Cells: Follow the same procedure as for **proflavine sulfate** staining.
- Primary and Secondary Antibody Incubation (for Immunofluorescence): If applicable, perform your immunofluorescence staining protocol.
- Counterstain with DAPI: After the final wash following secondary antibody incubation, add the 300 nM DAPI working solution to the coverslips and incubate for 1-5 minutes at room temperature, protected from light. [6]5. Wash: Briefly rinse the coverslips once with PBS.
- Mount: Mount the coverslips onto microscope slides, preferably with an antifade mounting medium.
- Image: Visualize using a fluorescence microscope with a DAPI filter set (e.g., excitation around 360 nm and emission around 460 nm). [13]



[Click to download full resolution via product page](#)

Caption: A generalized workflow for nuclear counterstaining.

## Conclusion: Selecting the Right Tool for the Job

Both **proflavine sulfate** and DAPI are effective nuclear counterstains, each with a distinct set of advantages and disadvantages.

Choose **Proflavine Sulfate** when:

- A green nuclear counterstain is required to avoid spectral overlap with blue or far-red fluorophores.
- Rapid staining of live cells is necessary, and potential cytotoxicity is a secondary concern.
- An intercalating dye is specifically needed for the experimental design.

Choose DAPI when:

- A bright, photostable blue nuclear stain is desired for high-contrast imaging.
- You are performing multicolor immunofluorescence with green and red probes.
- Staining fixed and permeabilized cells is the primary application.

Ultimately, the optimal choice of nuclear counterstain depends on the specific requirements of your experiment. By understanding the underlying principles of their mechanisms of action and their practical performance characteristics, researchers can make informed decisions to generate high-quality, reliable imaging data.

## References

- MyScope. (n.d.). Fluorescence Spectral Overlap. LFM. Retrieved from [\[Link\]](#)
- Radiology Key. (2016, April 2). Colocalization Analysis in Fluorescence Microscopy. Retrieved from [\[Link\]](#)
- Prieto, S. P., Powless, A. J., Boice, J. W., Sharma, S. G., & Muldoon, T. J. (2015). Proflavine Hemisulfate as a Fluorescent Contrast Agent for Point-of-Care Cytology. PLOS ONE, 10(5), e0125598.

- Boster Biological Technology. (2022, December 20). DAPI Staining: Fluorescent DNA Binding for Cell Imaging. Retrieved from [\[Link\]](#)
- Zheng, C., et al. (2015). Photoconversion of DAPI and Hoechst dyes to green and red emitting forms after exposure to UV excitation. *Histochemistry and Cell Biology*, 144(3), 245-251.
- FluoroFinder. (n.d.). DAPI Dye Profile. Retrieved from [\[Link\]](#)
- Creative Bioarray. (n.d.). DAPI Counterstaining Protocol. Retrieved from [\[Link\]](#)
- Oregon Medical Laser Center. (n.d.). Proflavin. Retrieved from [\[Link\]](#)
- Prieto, S. P., et al. (2015). Proflavine Hemisulfate as a Fluorescent Contrast Agent for Point-of-Care Cytology. *PLoS ONE*, 10(5), e0125598.
- Macsen Labs. (n.d.). Proflavine Hemisulphate | Structure, Uses & Side Effects. Retrieved from [\[Link\]](#)
- National Center for Biotechnology Information. (n.d.). PubChem Compound Summary for CID 7099, Proflavine. Retrieved from [\[Link\]](#)
- Prieto, S. P., Powless, A. J., Boice, J. W., Sharma, S. G., & Muldoon, T. J. (2015). Proflavine Hemisulfate as a Fluorescent Contrast Agent for Point-of-Care Cytology. *PLoS ONE*, 10(5), e0125598.
- Kozurková, M., et al. (2008). Cytotoxic activity of proflavine diureas: synthesis, antitumor, evaluation and DNA binding properties of 1',1''-(acridin-3,6-diyl)-3',3''-dialkyldiureas. *Bioorganic & Medicinal Chemistry*, 16(7), 3976-3984.
- National Center for Biotechnology Information. (n.d.). PubChem Compound Summary for CID 7099, Proflavine. Retrieved from [\[Link\]](#)
- Bio-Rad. (2016, June 16). Assessing Cell Health: Viability and Proliferation. *Bio-Radiations*. Retrieved from [\[Link\]](#)
- Mäntylä, E., et al. (2023). Iterative Immunostaining and NEDD Denoising for Improved Signal-To-Noise Ratio in ExM-LSCM. *bio-protocol*, 13(21), e4821.
- Thakur, A., et al. (2024). Comparing automated cell imaging with conventional methods of measuring cell proliferation and viability. *Bioscience Reports*, 44(6), BSR20232021.

- Kawedia, J. D., et al. (2014). Physical and chemical stability of proflavine contrast agent solutions for early detection of oral cancer. *Journal of compounding and pharmacy*, 18(6), 517-522.
- Scholar, S. (n.d.). Synthesis of proflavine derivatives and study of how they bind to DNA as potential chemotherapeutic agents. Retrieved from [[Link](#)]
- Starcevic Manning, M., et al. (2022). Comparison of Titer and Signal to Noise (S/N) for Determination of Anti-drug Antibody Magnitude Using Clinical Data from an Industry Consortium. *The AAPS Journal*, 24(4), 81.
- Tanious, F. A., et al. (1992). DAPI (4',6-diamidino-2-phenylindole) binds differently to DNA and RNA: minor-groove binding at AT sites and intercalation at AU sites. *Biochemistry*, 31(12), 3103-3112.
- Prieto, S. P., et al. (2015). Proflavine Hemisulfate as a Fluorescent Contrast Agent for Point-of-Care Cytology. *PLoS ONE*, 10(5), e0125598.
- National Center for Biotechnology Information. (n.d.). PubChem Compound Summary for CID 7099, Proflavine. Retrieved from [[Link](#)]
- Bio-Techne. (n.d.). ICC/IF Counterstaining & Mounting: DAPI, Dyes, and Mediums. Retrieved from [[Link](#)]
- ResearchGate. (2014, August 15). Can anyone help me to suggest using 4 colors for Immunofluorescent including nuclear staining?. Retrieved from [[Link](#)]
- ResearchGate. (2016, June 10). Can we use counterstain(DAPI) and secondary antibody(Alexa flour 488)?. Retrieved from [[Link](#)]
- Bio-Rad. (n.d.). Nuclear Staining Dyes - DAPI. Retrieved from [[Link](#)]

### ***Need Custom Synthesis?***

*BenchChem offers custom synthesis for rare earth carbides and specific isotopic labeling.*

*Email: [info@benchchem.com](mailto:info@benchchem.com) or [Request Quote Online](#).*

## **Sources**

- [1. bioagilytix.com \[bioagilytix.com\]](#)
- [2. Highly sensitive live-cell imaging-based cytotoxicity assay enables functional validation of rare epitope-specific CTLs - PMC \[pmc.ncbi.nlm.nih.gov\]](#)
- [3. researchgate.net \[researchgate.net\]](#)
- [4. pdf.benchchem.com \[pdf.benchchem.com\]](#)
- [5. creative-bioarray.com \[creative-bioarray.com\]](#)
- [6. Physical and chemical stability of proflavine contrast agent solutions for early detection of oral cancer - PubMed \[pubmed.ncbi.nlm.nih.gov\]](#)
- [7. Using the Fluorescence SpectraViewer—Note 23.1 | Thermo Fisher Scientific - HK \[thermofisher.com\]](#)
- [8. Practical Characterization Strategies for Comparison, Qualification, and Selection of Cell Viability Detection Methods for Cellular Therapeutic Product Development and Manufacturing - PubMed \[pubmed.ncbi.nlm.nih.gov\]](#)
- [9. Photoconversion of DAPI and Hoechst dyes to green and red emitting forms after exposure to UV excitation - PMC \[pmc.ncbi.nlm.nih.gov\]](#)
- [10. researchgate.net \[researchgate.net\]](#)
- [11. To dye or not to dye? Understanding the different viability dyes available for flow cytometry | Proteintech Group \[ptglab.com\]](#)
- [12. MyScope \[myscope.training\]](#)
- [13. Colocalization Analysis in Fluorescence Microscopy | Radiology Key \[radiologykey.com\]](#)
- [To cite this document: BenchChem. \[A Comparative Guide to Nuclear Counterstaining: Proflavine Sulfate vs. DAPI\]. BenchChem, \[2026\]. \[Online PDF\]. Available at: \[https://www.benchchem.com/product/b1218852/docs#a-comparative-guide-to-nuclear-counterstaining-proflavine-sulfate-vs-dapi\]](#)

---

### Disclaimer & Data Validity:

The information provided in this document is for Research Use Only (RUO) and is strictly not intended for diagnostic or therapeutic procedures. While BenchChem strives to provide accurate protocols, we make no warranties, express or implied, regarding the fitness of this product for every specific experimental setup.

**Technical Support:** The protocols provided are for reference purposes. Unsure if this reagent suits your experiment?

**Need Industrial/Bulk Grade?** [Request Custom Synthesis Quote](#)

## BenchChem

Our mission is to be the trusted global source of essential and advanced chemicals, empowering scientists and researchers to drive progress in science and industry.

### Contact

Address: 3281 E Guasti Rd  
Ontario, CA 91761, United States  
Phone: (601) 213-4426  
Email: [info@benchchem.com](mailto:info@benchchem.com)

[Contact our Ph.D. Support Team for a compatibility check](#)