

# Technical Support Center: Investigating Off-Target Effects of Vandetanib in Research Models

**Author:** BenchChem Technical Support Team. **Date:** April 2026

## Compound of Interest

Compound Name:	Vantal
CAS No.:	39474-56-1
Cat. No.:	B1217016

[Get Quote](#)

Disclaimer: The compound "**Vantal**" is not found in publicly available scientific literature or drug databases. This technical support guide has been created based on the well-researched multi-kinase inhibitor "Vandetanib," which is a likely intended subject of inquiry due to the similarity in name.

This guide is intended for researchers, scientists, and drug development professionals to understand and troubleshoot potential off-target effects of Vandetanib in experimental models.

## Frequently Asked Questions (FAQs)

Q1: What is the primary mechanism of action of Vandetanib?

A1: Vandetanib is an orally available, multi-targeted tyrosine kinase inhibitor (TKI).[1][2] Its primary mechanism of action involves the inhibition of three key receptor tyrosine kinases (RTKs) crucial for tumor growth, survival, and angiogenesis:

- Vascular Endothelial Growth Factor Receptor 2 (VEGFR-2): A primary mediator of angiogenesis, the formation of new blood vessels required for tumor growth.[3][4]

- Epidermal Growth Factor Receptor (EGFR): Often overexpressed in various cancers, leading to uncontrolled cell proliferation.[3][5]
- REarranged during Transfection (RET) Proto-Oncogene: A key driver in certain types of thyroid cancer, particularly medullary thyroid carcinoma (MTC).[3][6]

By binding to the ATP-binding site of these kinases, Vandetanib blocks their phosphorylation and subsequent activation, disrupting downstream signaling pathways like PI3K/AKT and MAPK.[3][7]

Q2: What are the known off-target kinases for Vandetanib?

A2: While Vandetanib is selective for VEGFR, EGFR, and RET kinases at nanomolar concentrations, it can inhibit other kinases at higher, micromolar concentrations. These are considered potential off-target effects in experimental models. Researchers should be aware of these interactions, especially when using higher doses. Known off-targets include VEGFR-3, PDGFR $\beta$ , TIE2, and members of the Src kinase family.[8]

Q3: My experimental results are inconsistent with the known on-target effects of Vandetanib. How can I determine if I'm observing an off-target effect?

A3: This is a common challenge in targeted therapy research. Here are some troubleshooting steps:

- Dose-Response Analysis: Compare the concentration of Vandetanib at which you observe the unexpected phenotype with the known IC50 values for its primary targets. If the effect occurs at a significantly higher concentration, it may be an off-target effect.[9]
- Use a Structurally Unrelated Inhibitor: If possible, use a different inhibitor with a distinct chemical structure that targets the same primary kinase (e.g., a highly selective EGFR inhibitor if you are studying EGFR-dependent effects). If the phenotype does not replicate, it suggests the original observation was due to an off-target effect of Vandetanib.[10]
- Rescue Experiment: In a cell-based model, if you can express a drug-resistant mutant of the primary target kinase, this should reverse the on-target effects of Vandetanib. If the phenotype persists, it is likely mediated by an off-target.[9]

- Kinome Profiling: The most direct method is to perform a kinome-wide selectivity screen. This involves testing Vandetanib against a large panel of purified kinases to identify unintended targets.[\[10\]](#)[\[11\]](#)

Q4: What are some common physiological effects observed in animal models that could be attributed to off-target activities?

A4: In preclinical animal models, some observed toxicities may be linked to off-target effects or exaggerated on-target inhibition. For Vandetanib, these can include:

- Hypertension: This is a known class effect for VEGFR inhibitors and has been observed with Vandetanib in rat models. It is associated with vasoconstriction.[\[12\]](#)
- QT Prolongation: Vandetanib can affect cardiac ion channels, leading to a prolongation of the QT interval on an electrocardiogram (ECG), which can be a safety concern.[\[13\]](#)[\[14\]](#)
- Diarrhea and Rash: These are common side effects, often associated with EGFR inhibition.  
[\[2\]](#)[\[14\]](#)

## Troubleshooting Guides

### Guide 1: Differentiating On-Target vs. Off-Target Cytotoxicity

Symptom/Observation	Possible Cause	Troubleshooting Steps
Unexpectedly high cytotoxicity in a cell line with low expression of primary targets (VEGFR, EGFR, RET).	The cytotoxicity may be driven by an off-target kinase that is highly expressed or critical for survival in that specific cell line.	<ol style="list-style-type: none"> <li>1. Confirm Target Expression: Verify the expression levels of VEGFR-2, EGFR, and RET in your cell line via Western blot or qPCR.</li> <li>2. Compare IC50 Values: Perform a dose-response curve and compare the cytotoxic IC50 to the known enzymatic IC50 values for on-target kinases (see Table 1). A large discrepancy suggests off-target activity.</li> <li>3. Kinome Profiling: Screen Vandetanib against a kinase panel to identify potential off-targets.<a href="#">[10]</a></li> </ol>
Phenotype (e.g., apoptosis, cell cycle arrest) does not correlate with inhibition of downstream pathways of primary targets.	The observed phenotype may be due to the inhibition of an alternative signaling pathway via an off-target kinase.	<ol style="list-style-type: none"> <li>1. Pathway Analysis: Use Western blotting to probe for the phosphorylation status of key proteins in the canonical VEGFR, EGFR, and RET pathways (e.g., p-AKT, p-ERK).<a href="#">[7]</a></li> <li>2. Investigate Alternative Pathways: If the primary pathways are not inhibited at the effective concentration, consider probing other known off-target pathways (e.g., those downstream of PDGFR<math>\beta</math> or Src).</li> </ol>

## Data Presentation

### Table 1: In Vitro Kinase Inhibition Profile of Vandetanib

This table summarizes the inhibitory concentrations (IC50) of Vandetanib against its primary targets and selected off-targets. These values are crucial for designing experiments and interpreting results.

Kinase Target	IC50 (nM)	Notes
Primary Targets		
VEGFR-2 (KDR)	40	High-potency inhibition, key for anti-angiogenic effects.[15]
RET	130	Potent inhibition, relevant for RET-driven cancers like MTC. [15]
EGFR	500	Moderate potency, contributes to anti-proliferative effects.[15]
Potential Off-Targets		
VEGFR-3 (Flt-4)	110	Structurally related to VEGFR-2; also involved in angiogenesis.[15]
PDGFR $\beta$	1,100	Inhibition at micromolar concentrations.
TIE-2 (TEK)	>3,000	Lower potency; may be relevant at high experimental doses.
c-Kit	>10,000	Unlikely to be a significant off-target.
FGFR1	3,600	Low potency inhibition.

Data compiled from recombinant enzyme assays.

## Experimental Protocols

### Protocol 1: In Vitro Kinase Profiling Assay

This protocol provides a general framework for screening Vandetanib against a panel of kinases to identify off-targets.

**Objective:** To determine the selectivity of Vandetanib by measuring its inhibitory activity against a broad range of purified kinases.

**Methodology:**

- **Compound Preparation:** Prepare a stock solution of Vandetanib in DMSO. Perform serial dilutions to create a range of concentrations for IC50 determination.
- **Kinase Reaction Setup:** In a 96-well or 384-well plate, add the kinase buffer, the specific peptide substrate for each kinase, and the purified recombinant kinase.
- **Inhibitor Addition:** Add the diluted Vandetanib or vehicle control (DMSO) to the appropriate wells.
- **Reaction Initiation:** Initiate the kinase reaction by adding a solution of ATP.
- **Incubation:** Incubate the plate at 30°C for a specified period (e.g., 60 minutes), allowing for substrate phosphorylation.
- **Detection:** Stop the reaction and detect kinase activity. A common method is to use an ADP-Glo™ Kinase Assay, which measures the amount of ADP produced as a luminescent signal. This signal is inversely proportional to the inhibitory activity of Vandetanib.[\[9\]](#)
- **Data Analysis:** Calculate the percentage of inhibition for each concentration relative to the vehicle control. Plot the percent inhibition against the logarithm of Vandetanib concentration and fit the data to a sigmoidal dose-response curve to determine the IC50 value for each kinase.

## Protocol 2: Cellular Thermal Shift Assay (CETSA) for Target Engagement

**Objective:** To confirm that Vandetanib engages with its intended targets (and potential off-targets) within intact cells.

**Methodology:**

- **Cell Treatment:** Culture cells to ~80% confluency. Treat the cells with Vandetanib at the desired concentration or with a vehicle control for a specified time.
- **Harvesting:** Harvest the cells, wash with PBS, and resuspend in a buffer.
- **Heat Shock:** Aliquot the cell suspension into PCR tubes and heat them to a range of different temperatures for 3 minutes to induce protein denaturation.
- **Cell Lysis:** Lyse the cells by freeze-thawing.
- **Separation:** Separate the soluble (non-denatured) protein fraction from the precipitated (denatured) fraction by centrifugation.
- **Analysis:** Analyze the amount of the target protein in the soluble fraction using Western blotting or mass spectrometry.
- **Data Interpretation:** Binding of Vandetanib to a target protein stabilizes it, leading to a higher melting temperature. This is observed as a shift in the melting curve to the right (i.e., more protein remains soluble at higher temperatures) in the Vandetanib-treated samples compared to the control. This confirms target engagement in a cellular context.

## Visualizations

### Signaling Pathways

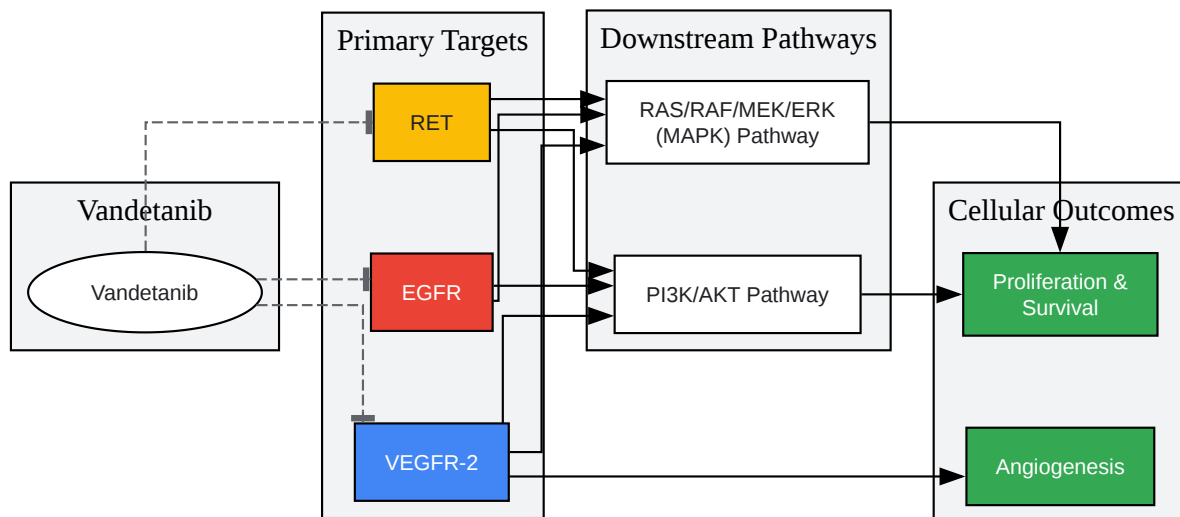

[Click to download full resolution via product page](#)

Caption: Vandetanib inhibits VEGFR-2, EGFR, and RET, blocking key downstream pathways.

## Experimental Workflow

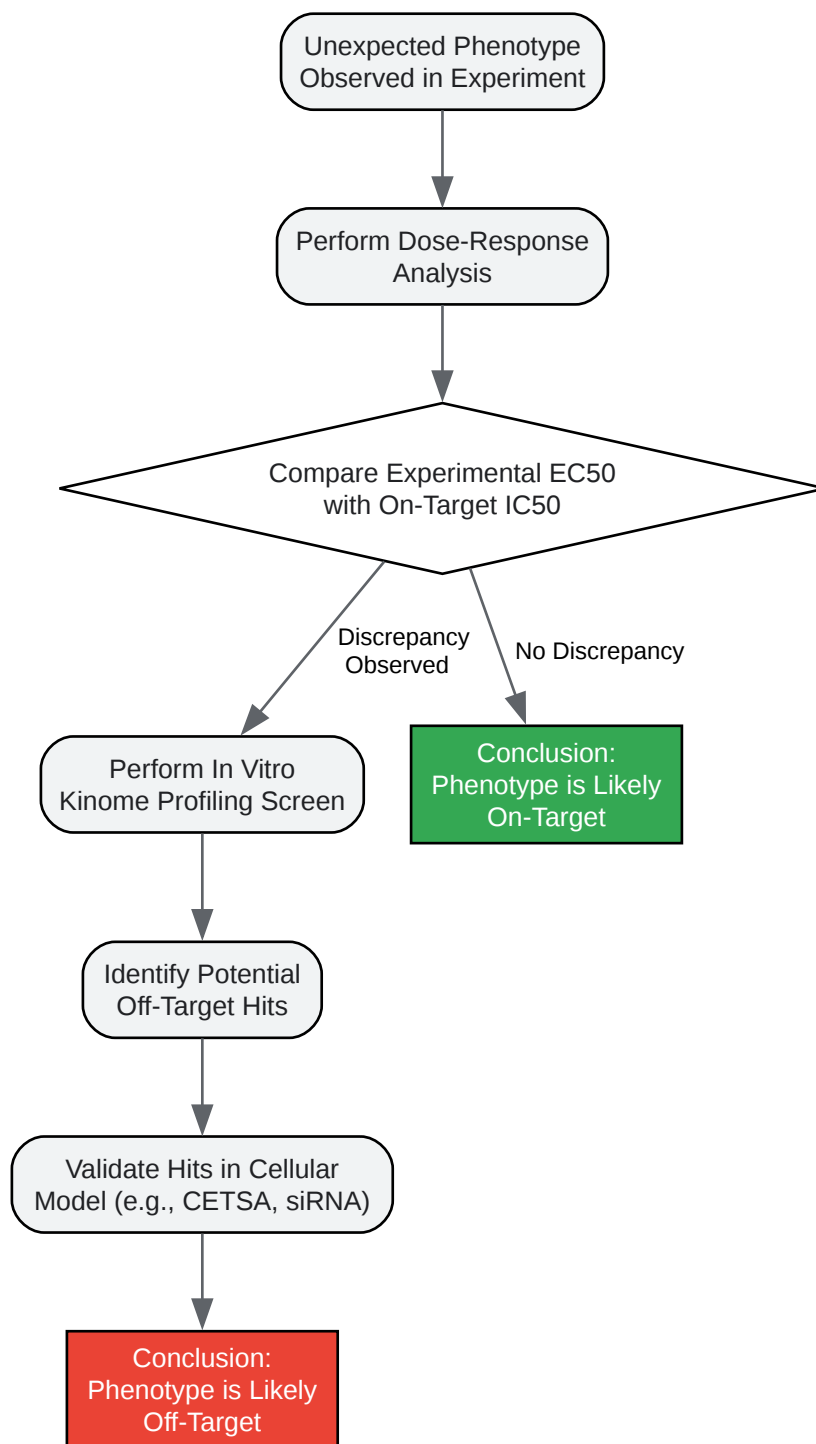

[Click to download full resolution via product page](#)

Caption: Workflow for investigating potential off-target effects of kinase inhibitors.

## Logical Relationship

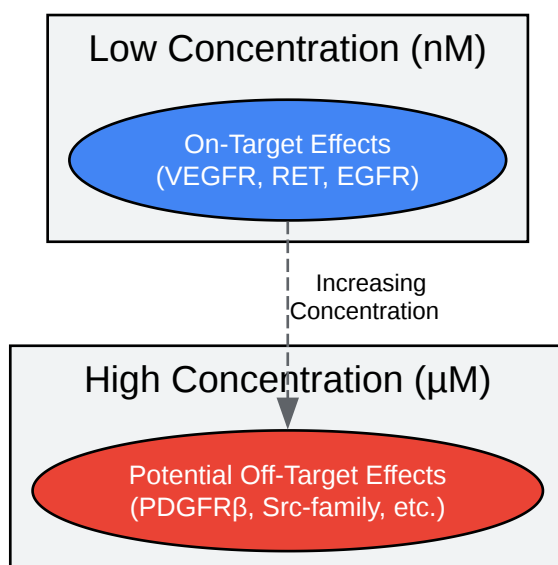

[Click to download full resolution via product page](#)

Caption: Relationship between Vandetanib concentration and on-/off-target effects.

### Need Custom Synthesis?

BenchChem offers custom synthesis for rare earth carbides and specific isotopic labeling.

Email: [info@benchchem.com](mailto:info@benchchem.com) or [Request Quote Online](#).

## References

- 1. Vandetanib (ZD6474): an orally available receptor tyrosine kinase inhibitor that selectively targets pathways critical for tumor growth and angiogenesis - PubMed [[pubmed.ncbi.nlm.nih.gov](http://pubmed.ncbi.nlm.nih.gov)]
- 2. [researchgate.net](http://researchgate.net) [[researchgate.net](http://researchgate.net)]
- 3. What is the mechanism of Vandetanib? [[synapse.patsnap.com](http://synapse.patsnap.com)]
- 4. Vandetanib, a novel multitargeted kinase inhibitor, in cancer therapy - PubMed [[pubmed.ncbi.nlm.nih.gov](http://pubmed.ncbi.nlm.nih.gov)]
- 5. Vandetanib | C22H24BrFN4O2 | CID 3081361 - PubChem [[pubchem.ncbi.nlm.nih.gov](http://pubchem.ncbi.nlm.nih.gov)]
- 6. [researchgate.net](http://researchgate.net) [[researchgate.net](http://researchgate.net)]

- 7. Changes in signaling pathways induced by vandetanib in a human medullary thyroid carcinoma model, as analyzed by reverse phase protein array - PubMed [[pubmed.ncbi.nlm.nih.gov](https://pubmed.ncbi.nlm.nih.gov)]
- 8. Vandetanib mediates anti-leukemia activity by multiple mechanisms and interacts synergistically with DNA damaging agents - PMC [[pmc.ncbi.nlm.nih.gov](https://pubmed.ncbi.nlm.nih.gov)]
- 9. [benchchem.com](https://www.benchchem.com) [[benchchem.com](https://www.benchchem.com)]
- 10. [benchchem.com](https://www.benchchem.com) [[benchchem.com](https://www.benchchem.com)]
- 11. [reactionbiology.com](https://www.reactionbiology.com) [[reactionbiology.com](https://www.reactionbiology.com)]
- 12. Long-term cardiovascular effects of vandetanib and pazopanib in normotensive rats - PMC [[pmc.ncbi.nlm.nih.gov](https://pubmed.ncbi.nlm.nih.gov)]
- 13. [oncolink.org](https://www.oncolink.org) [[oncolink.org](https://www.oncolink.org)]
- 14. [taylorandfrancis.com](https://www.taylorandfrancis.com) [[taylorandfrancis.com](https://www.taylorandfrancis.com)]
- 15. Clinical utility of vandetanib in the treatment of patients with advanced medullary thyroid cancer - PMC [[pmc.ncbi.nlm.nih.gov](https://pubmed.ncbi.nlm.nih.gov)]
- To cite this document: BenchChem. [Technical Support Center: Investigating Off-Target Effects of Vandetanib in Research Models]. BenchChem, [2026]. [Online PDF]. Available at: [<https://www.benchchem.com/product/b1217016/docs#technical-support-center-investigating-off-target-effects-of-vandetanib-in-research-models>]

---

### Disclaimer & Data Validity:

The information provided in this document is for Research Use Only (RUO) and is strictly not intended for diagnostic or therapeutic procedures. While BenchChem strives to provide accurate protocols, we make no warranties, express or implied, regarding the fitness of this product for every specific experimental setup.

**Technical Support:** The protocols provided are for reference purposes. Unsure if this reagent suits your experiment?

**Need Industrial/Bulk Grade?** [Request Custom Synthesis Quote](#)

# BenchChem

Our mission is to be the trusted global source of essential and advanced chemicals, empowering scientists and researchers to drive progress in science and industry.

## Contact

Address: 3281 E Guasti Rd

Ontario, CA 91761, United States

Phone: (601) 213-4426

Email: [info@benchchem.com](mailto:info@benchchem.com)

[Contact our Ph.D. Support Team for a compatibility check](#)