

The Anilide Scaffold: A Comprehensive Guide to Structure-Activity Relationship Fundamentals

Author: BenchChem Technical Support Team. **Date:** April 2026

Compound of Interest

Compound Name:	Anilix
CAS No.:	8072-20-6
Cat. No.:	B1216903

[Get Quote](#)

For Researchers, Scientists, and Drug Development Professionals

The anilide functional group, characterized by an N-phenyl amide linkage, is a privileged scaffold in medicinal chemistry. Its derivatives have given rise to a diverse array of therapeutic agents, from potent opioid analgesics to targeted anticancer drugs. However, the anilide motif is also a well-known "structural alert" due to its potential for metabolic bioactivation into reactive, toxic species. A thorough understanding of the structure-activity relationships (SAR) and structure-toxicity relationships (STR) is therefore critical for the successful design and development of safe and effective anilide-based drugs. This in-depth technical guide explores the core SAR fundamentals of key anilide classes, provides quantitative data for analysis, details essential experimental protocols, and visualizes the underlying principles and pathways.

Core Principles of Anilide Structure-Activity Relationships

The biological activity of anilide-containing compounds can be finely tuned by strategic modifications at two primary locations: the aniline ring and the acyl moiety. The interplay of

electronic and steric factors at these positions dictates the compound's potency, selectivity, and pharmacokinetic profile.

1. The Aniline Ring: The Role of Substituents

Substituents on the aniline (phenyl) ring play a crucial role in modulating the electronic environment of the amide nitrogen and the overall lipophilicity and conformation of the molecule. These effects are primarily governed by two principles:

- **Inductive Effects (I):** This effect is transmitted through sigma (σ) bonds and arises from electronegativity differences. Electron-withdrawing groups (EWGs) like nitro ($-\text{NO}_2$), cyano ($-\text{CN}$), and halogens ($-\text{Cl}$, $-\text{F}$) pull electron density away from the ring ($-I$ effect). Conversely, electron-donating groups (EDGs) such as alkyl groups ($-\text{CH}_3$) push electron density towards the ring ($+I$ effect).[1]
- **Resonance Effects (M or R):** This effect involves the delocalization of π -electrons and lone pairs between the substituent and the aromatic system. Substituents with lone pairs adjacent to the ring (e.g., $-\text{OH}$, $-\text{NH}_2$) can donate electron density into the ring ($+M$ effect), while groups with π -bonds to electronegative atoms (e.g., $-\text{C}=\text{O}$, $-\text{NO}_2$) can withdraw electron density ($-M$ effect).[2]

The net effect of a substituent is a combination of these two factors. For instance, halogens are inductively withdrawing ($-I$) but have a weak resonance donating effect ($+M$). For anilides, EWGs on the aniline ring can influence the acidity of the N-H proton, which can be critical for receptor binding. The position of the substituent (ortho, meta, or para) also significantly impacts these electronic effects and can introduce steric hindrance that affects the molecule's ability to adopt an active conformation.

2. The Acyl Moiety: Dictating Specificity and Potency

The nature of the acyl group ($\text{R}-\text{C}=\text{O}$) is fundamental in defining the specific class of anilide and its biological target. This portion of the molecule often engages in key interactions, such as hydrogen bonding, with the target protein. Variations in the 'R' group can dramatically alter potency and selectivity. For example, in the 4-anilinopiperidine class of opioids, a simple propionyl group on the anilide nitrogen is optimal for potent μ -opioid receptor agonism.[3] In

salicylanilides, the acyl portion is a salicylic acid ring, and substitutions on this ring are critical for their anthelmintic and anticancer activities.

Quantitative Structure-Activity Relationship (QSAR) Data

Summarizing SAR data in a quantitative format is essential for discerning trends and designing new, improved analogues. QSAR models aim to find a statistical correlation between chemical structure (represented by physicochemical descriptors) and biological activity.^[4]

Table 1: SAR of 4-Anilinopiperidine-Based Mu-Opioid Receptor (MOR) Agonists

This class of compounds, which includes the potent analgesic fentanyl, demonstrates how modifications to the core scaffold dramatically impact receptor binding affinity (K_i) and in vivo analgesic potency (ED_{50}).

Compound	R1 (N-substituent)	R2 (Piperidine 3-position)	R3 (Piperidine 4-position)	R4 (Anilide N-acyl group)	Ki (nM) for MOR	ED50 (mg/kg) (Hot-Plate, Mouse)
Fentanyl	Phenethyl	H	H	Propanoyl	1.23 - 1.4	0.011
Alfentanil	(4-ethyl-4,5-dihydro-5-oxo-1H-tetrazol-1-yl)ethyl	H	H	Propanoyl	~1.1	0.03
Sufentanil	2-(2-thienyl)ethyl	H	Methoxymethyl	Propanoyl	0.138	0.0006
Remifentanyl	Methyl propanoate-ethyl	H	H	Propanoyl	1.3	0.003
Carfentanil	Phenethyl	H	Methoxymethyl	Propanoyl	0.034	0.00032

Data compiled from BenchChem SAR Guide.^[3] Note: Ki and ED50 values can vary between studies due to different experimental conditions.

SAR Insights from Table 1:

- N-substituent (R1): A phenethyl group or a bioisosteric equivalent like the 2-thienylethyl group is crucial for high potency.
- Piperidine 4-position (R3): Introduction of a methoxymethyl group, as seen in Sufentanil and Carfentanil, significantly increases potency.
- Anilide N-acyl group (R4): The N-propanoyl group is optimal for MOR affinity.

Table 2: Anticancer Activity of Salicylanilide Derivatives

Salicylanilides, originally used as anthelmintics, have been repurposed as anticancer agents. Their activity is highly dependent on the substitution pattern on both aromatic rings.

Halogenation is a common feature of active compounds.

Compound	Salicyl Ring Substitution	Aniline Ring Substitution	IC50 (μM) on THP-1 cells
Salicylanilide 1	5-Cl	4-CF ₃	1.4
Salicylanilide 2	5-Cl	4-Cl	2.1
Salicylanilide 3	3,5-di-Cl	4-CF ₃	1.6
Salicylanilide 4	3,5-di-Cl	4-Cl	1.9
Niclosamide	5-Cl	4'-Cl, 2'-NO ₂	~1.0 (Varies by cell line)

Data adapted from a study on salicylanilide-based peptidomimetics.[5] The anticancer activity often increases with increasing lipophilicity.[5]

SAR Insights from Table 2:

- Halogenation: The presence of halogens (e.g., Cl, CF₃) on both the salicyl and aniline rings is consistently associated with potent activity.[5]
- Aniline Ring: Electron-withdrawing groups like -CF₃ and -Cl at the 4-position of the aniline ring are favorable.
- Salicyl Ring: A chlorine at the 5-position is a common feature. Additional halogenation can further modulate activity.

Experimental Protocols

Detailed and standardized experimental protocols are crucial for the accurate evaluation and comparison of anilide derivatives.

Protocol 1: In Vitro Kinase Inhibition Assay (Luminescence-Based)

This assay determines the IC₅₀ value of a compound against a specific kinase by measuring the amount of ATP remaining after the kinase reaction.

Materials:

- Recombinant kinase enzyme
- Specific peptide substrate for the kinase
- Anilide test compounds (dissolved in DMSO)
- Kinase reaction buffer (containing MgCl₂)
- ATP solution (at or near the K_m for the kinase)
- Kinase-Glo® Luminescent Kinase Assay Kit
- White, opaque 96-well plates
- Plate-reading luminometer

Procedure:

- **Compound Preparation:** Perform serial dilutions of the anilide test compounds in the kinase reaction buffer. The final DMSO concentration should not exceed 1%.
- **Reaction Setup:** In a 96-well plate, add the following to each well:
 - Kinase reaction buffer.
 - Test compound at various concentrations (or DMSO for control).
 - A mixture of the kinase enzyme and its peptide substrate.
- **Reaction Initiation:** Initiate the kinase reaction by adding the ATP solution to each well.

- Incubation: Incubate the plate at room temperature for a defined period (e.g., 30-60 minutes).
- Detection:
 - Allow the Kinase-Glo® reagent to equilibrate to room temperature.
 - Add a volume of Kinase-Glo® reagent equal to the reaction volume in each well.
 - Mix briefly on a plate shaker and incubate at room temperature for 10 minutes to stabilize the luminescent signal.
- Data Acquisition: Measure the luminescence using a plate-reading luminometer.
- Data Analysis: The luminescent signal is inversely proportional to kinase activity. Calculate the percent inhibition for each compound concentration relative to the DMSO control. Determine the IC50 value by fitting the data to a sigmoidal dose-response curve.[\[6\]](#)

Protocol 2: Western Blot Analysis for NF-κB Pathway Activation

This protocol is used to detect changes in the levels of key proteins in the NF-κB signaling pathway, such as the phosphorylation of IκBα and the nuclear translocation of the p65 subunit, after treatment with an anilide compound.

Materials:

- Cell culture reagents and cells (e.g., RAW 264.7 macrophages)
- Anilide test compound and inflammatory stimulus (e.g., LPS)
- Cell lysis buffer (e.g., RIPA buffer) with protease and phosphatase inhibitors
- Nuclear and cytoplasmic extraction kits
- BCA protein assay kit
- SDS-PAGE gels, running buffer, and transfer apparatus

- PVDF or nitrocellulose membranes
- Blocking buffer (e.g., 5% non-fat milk or BSA in TBST)
- Primary antibodies (e.g., anti-p-I κ B α , anti-I κ B α , anti-p65, anti-Lamin B1, anti- β -tubulin)
- HRP-conjugated secondary antibodies
- Enhanced chemiluminescence (ECL) substrate
- Imaging system

Procedure:

- Cell Treatment: Seed cells and allow them to adhere. Pre-treat cells with the anilide compound for a specified time, then stimulate with an inflammatory agent like LPS to activate the NF- κ B pathway.
- Protein Extraction:
 - For total protein, lyse cells directly with lysis buffer.
 - For nuclear translocation studies, separate cytoplasmic and nuclear fractions using a specialized kit.
- Protein Quantification: Determine the protein concentration of each lysate using a BCA assay.
- SDS-PAGE: Load equal amounts of protein (e.g., 20-40 μ g) per lane onto an SDS-PAGE gel and separate the proteins by electrophoresis.
- Protein Transfer: Transfer the separated proteins from the gel to a PVDF or nitrocellulose membrane.
- Blocking: Block the membrane with blocking buffer for at least 1 hour at room temperature to prevent non-specific antibody binding.

- **Primary Antibody Incubation:** Incubate the membrane with the desired primary antibody (diluted in blocking buffer) overnight at 4°C with gentle agitation.
- **Secondary Antibody Incubation:** Wash the membrane three times with wash buffer (e.g., TBST). Incubate with the appropriate HRP-conjugated secondary antibody for 1 hour at room temperature.
- **Detection:** Wash the membrane again thoroughly. Apply the ECL substrate and visualize the protein bands using an imaging system.
- **Analysis:** Quantify the band intensities using densitometry software. Normalize the levels of phosphorylated proteins to their total protein counterparts. For translocation, normalize the nuclear p65 signal to a nuclear loading control (Lamin B1) and the cytoplasmic signal to a cytoplasmic loading control (β -tubulin).^{[7][8]}

Mandatory Visualizations

Diagrams created using Graphviz (DOT language) are provided to illustrate key workflows and biological pathways relevant to anilide SAR.

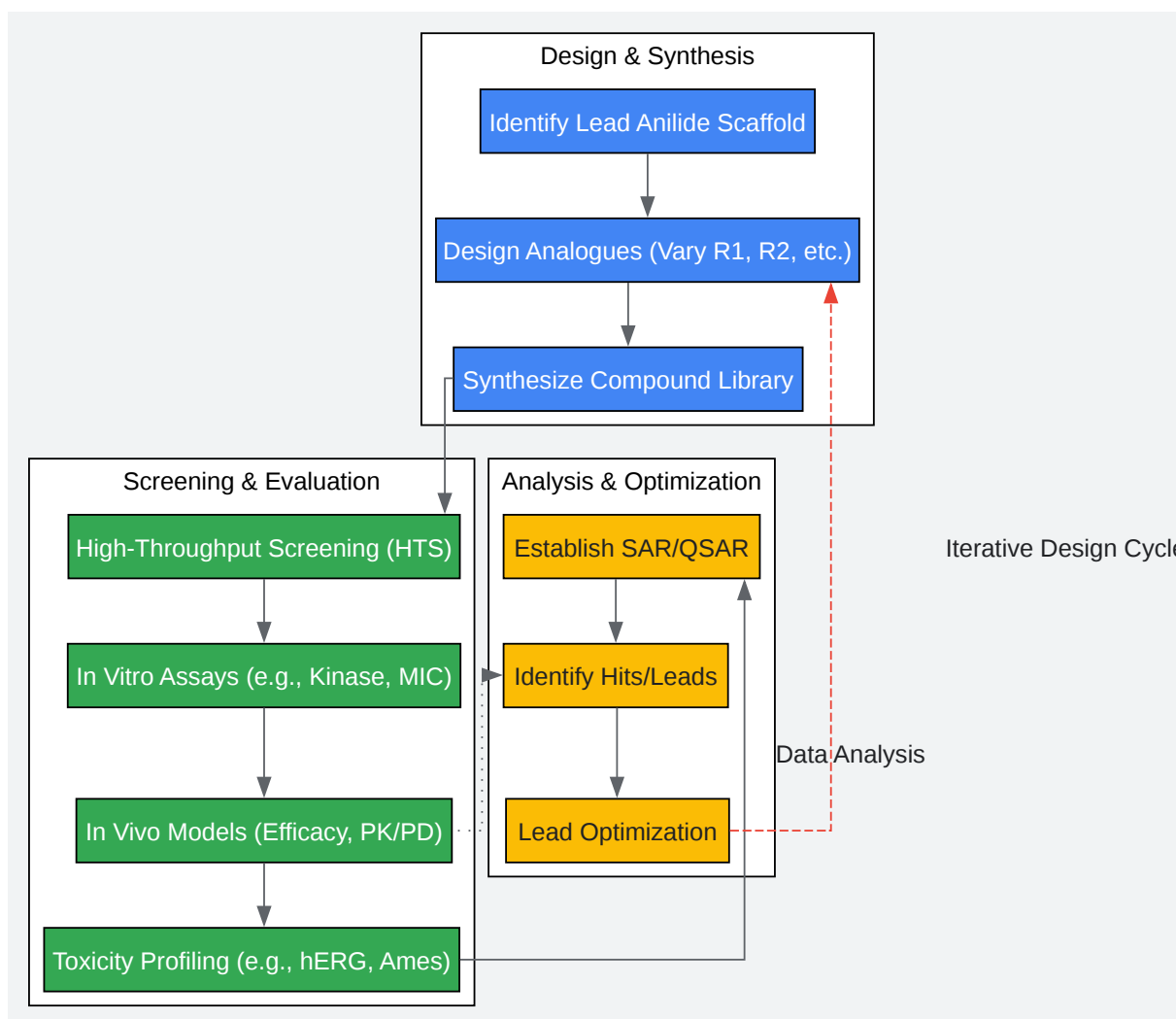

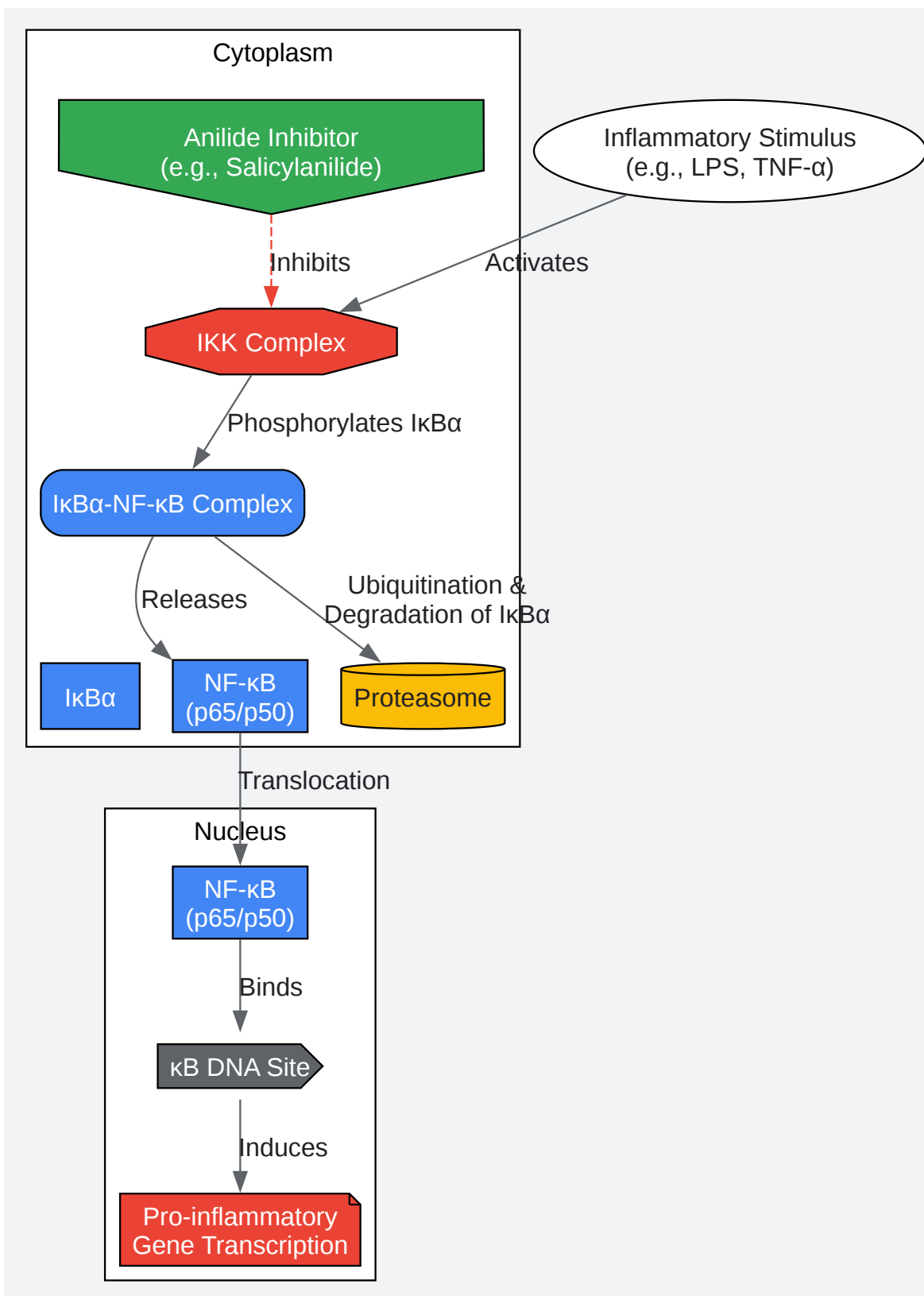

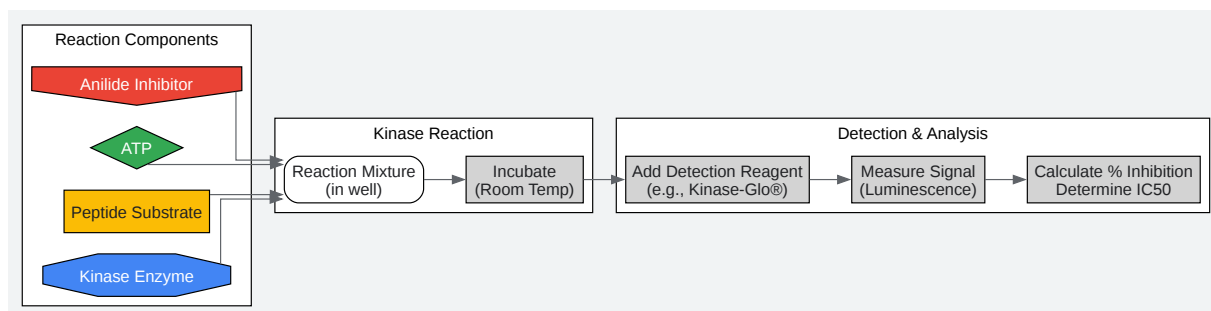

[Click to download full resolution via product page](#)

Need Custom Synthesis?

BenchChem offers custom synthesis for rare earth carbides and specific isotopic labeling.

Email: info@benchchem.com or [Request Quote Online](#).

References

- [1. benchchem.com \[benchchem.com\]](#)
- [2. reddit.com \[reddit.com\]](#)
- [3. benchchem.com \[benchchem.com\]](#)
- [4. benchchem.com \[benchchem.com\]](#)
- [5. mdpi.com \[mdpi.com\]](#)
- [6. benchchem.com \[benchchem.com\]](#)
- [7. benchchem.com \[benchchem.com\]](#)
- [8. benchchem.com \[benchchem.com\]](#)

- To cite this document: BenchChem. [The Anilide Scaffold: A Comprehensive Guide to Structure-Activity Relationship Fundamentals]. BenchChem, [2026]. [Online PDF]. Available at: [<https://www.benchchem.com/product/b1216903/docs#the-anilide-scaffold-a-comprehensive-guide-to-structure-activity-relationship-fundamentals>]

Disclaimer & Data Validity:

The information provided in this document is for Research Use Only (RUO) and is strictly not intended for diagnostic or therapeutic procedures. While BenchChem strives to provide accurate protocols, we make no warranties, express or implied, regarding the fitness of this product for every specific experimental setup.

Technical Support: The protocols provided are for reference purposes. Unsure if this reagent suits your experiment?

Need Industrial/Bulk Grade? [Request Custom Synthesis Quote](#)

BenchChem

Our mission is to be the trusted global source of essential and advanced chemicals, empowering scientists and researchers to drive progress in science and industry.

Contact

Address: 3281 E Guasti Rd
Ontario, CA 91761, United States
Phone: (601) 213-4426
Email: info@benchchem.com

[Contact our Ph.D. Support Team for a compatibility check](#)