

# Anilide Derivatives: A Comprehensive Technical Guide to Their Biological Significance

**Author:** BenchChem Technical Support Team. **Date:** April 2026

## Compound of Interest

Compound Name:	Anilix
CAS No.:	8072-20-6
Cat. No.:	B1216903

[Get Quote](#)

For Researchers, Scientists, and Drug Development Professionals

## Introduction

Anilide derivatives, a versatile class of organic compounds characterized by an amide linkage to a phenyl group, represent a cornerstone in medicinal chemistry and drug discovery. Their unique structural features allow for a wide range of modifications, leading to a diverse array of biological activities. This technical guide provides an in-depth exploration of the synthesis, biological significance, and mechanisms of action of anilide derivatives, with a focus on their applications as anticancer, antimicrobial, antiviral, and local anesthetic agents. Detailed experimental protocols and quantitative data are presented to facilitate further research and development in this critical area.

## Synthesis of Anilide Derivatives

The synthesis of anilide derivatives is typically achieved through the acylation of anilines. A general and widely used method involves the reaction of a substituted or unsubstituted aniline with an acylating agent such as an acyl chloride or an acid anhydride.[1]

A representative synthetic scheme is as follows:

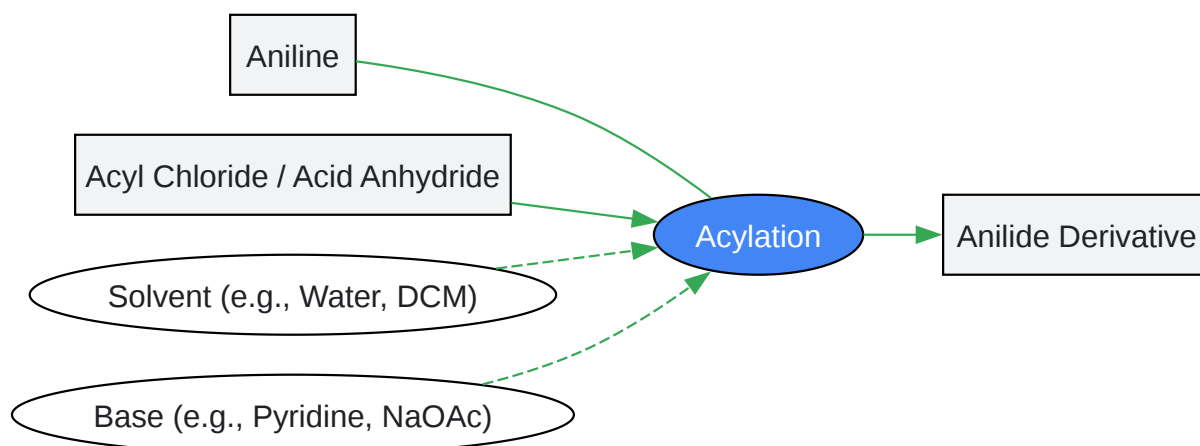

[Click to download full resolution via product page](#)

General synthesis of anilide derivatives.

This straightforward and adaptable synthesis allows for the creation of large libraries of anilide derivatives for biological screening.

## Anticancer Activity

Anilide derivatives have emerged as a significant class of anticancer agents, with several compounds approved for clinical use and many more under investigation. Their mechanisms of action are diverse, often targeting key signaling pathways involved in cancer cell proliferation, survival, and angiogenesis.

## Kinase Inhibition

A prominent group of anilide-based anticancer drugs are tyrosine kinase inhibitors (TKIs). These drugs target specific tyrosine kinases that are constitutively activated in various cancers, leading to uncontrolled cell growth.

Prominent Anilide-Based Tyrosine Kinase Inhibitors:

- Nilotinib: A potent inhibitor of the BCR-ABL kinase, the hallmark of chronic myeloid leukemia (CML).[2][3] It binds to the ATP-binding site of the inactive conformation of the ABL kinase

domain with greater affinity than imatinib.[2]

- Bosutinib: A dual inhibitor of Src and Abl tyrosine kinases.[4][5] It is effective against many imatinib-resistant BCR-ABL mutations.[4] Bosutinib has been shown to suppress neuroblastoma growth by inhibiting Src/Abl signaling and downstream pathways like PI3K/AKT/mTOR, MAPK/ERK, and JAK/STAT3.[6]
- Sorafenib: A multi-kinase inhibitor that targets Raf kinases (C-RAF, B-RAF) and receptor tyrosine kinases such as VEGFR and PDGFR.[7][8] This dual mechanism allows Sorafenib to inhibit both tumor cell proliferation and angiogenesis.[8]

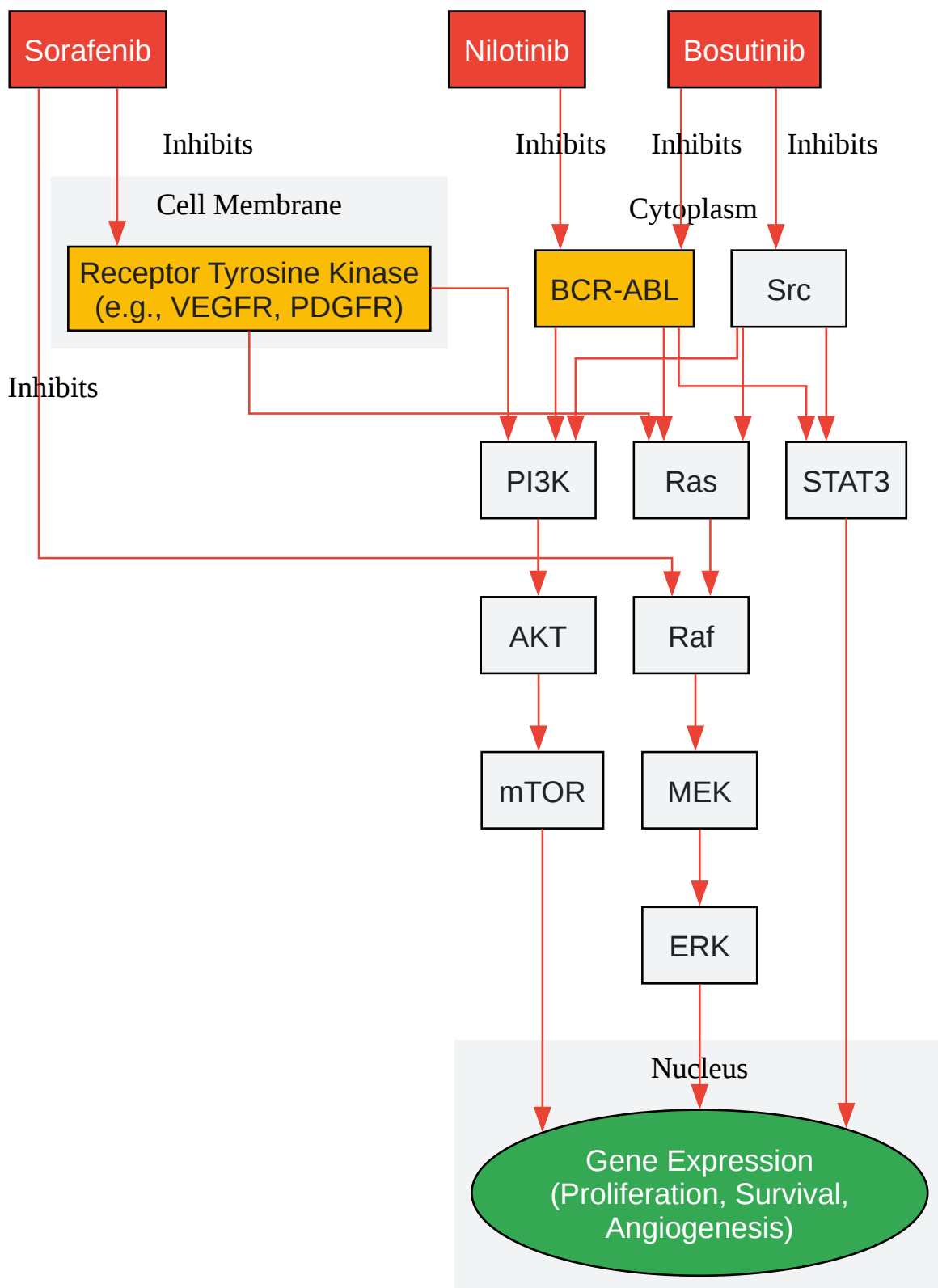

[Click to download full resolution via product page](#)

Signaling pathways targeted by anilide kinase inhibitors.

## Histone Deacetylase (HDAC) Inhibition

Some anilide derivatives function as histone deacetylase (HDAC) inhibitors. HDACs are enzymes that play a crucial role in the epigenetic regulation of gene expression. Their inhibition can lead to the re-expression of tumor suppressor genes, cell cycle arrest, and apoptosis.

## Quantitative Anticancer Activity Data

The following table summarizes the in vitro anticancer activity of selected anilide derivatives against various cancer cell lines.

Compound	Cancer Cell Line	Assay	IC50 ( $\mu\text{M}$ )	Reference
Pegaharoline A	A549 (NSCLC)	MTT	$2.39 \pm 0.27$	[9]
Pegaharoline A	PC9 (NSCLC)	MTT	$3.60 \pm 0.41$	[9]
ICD-85	A549 (NSCLC)	MTT	$22.23 \pm 2.42$ $\mu\text{g/ml}$	[10]
SMU-A0B13	HEK-Blue hTLR2	-	$18.21 \pm 0.87$	[11]

## Experimental Protocol: MTT Assay for Cytotoxicity

The MTT (3-(4,5-dimethylthiazol-2-yl)-2,5-diphenyltetrazolium bromide) assay is a colorimetric method used to assess cell viability.[12][13]

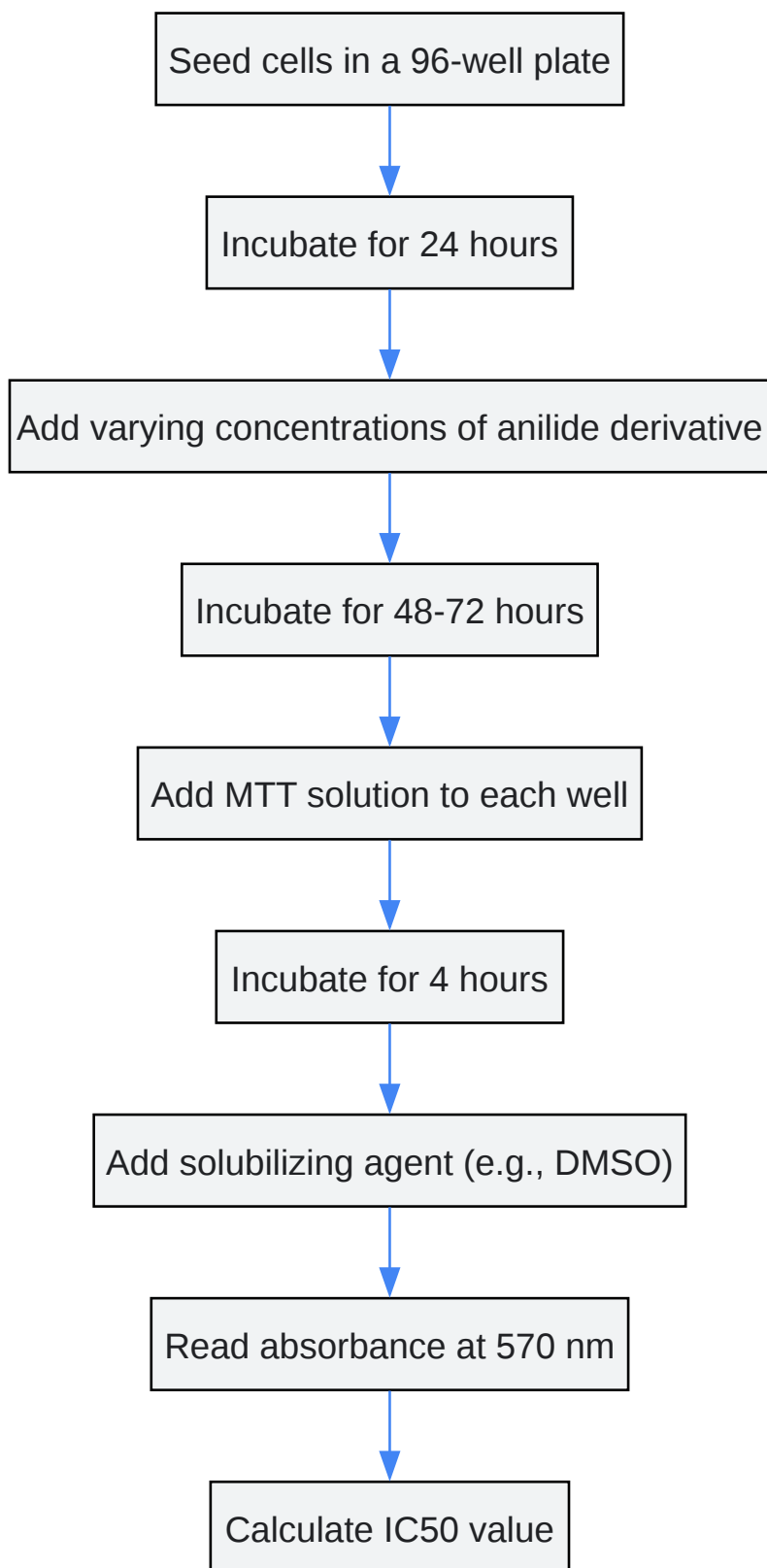

[Click to download full resolution via product page](#)

Workflow for the MTT cytotoxicity assay.

#### Detailed Steps:

- Cell Seeding: Seed cells into a 96-well plate at a density of 5,000-10,000 cells per well and incubate for 24 hours.[14]
- Compound Treatment: Treat the cells with a serial dilution of the anilide derivative and incubate for the desired period (e.g., 48 or 72 hours).[12]
- MTT Addition: Add 10  $\mu$ L of MTT solution (5 mg/mL in PBS) to each well and incubate for 4 hours at 37°C.[14]
- Formazan Solubilization: Remove the medium and add 100  $\mu$ L of a solubilizing agent (e.g., DMSO) to each well to dissolve the formazan crystals.[12]
- Absorbance Measurement: Measure the absorbance at 570 nm using a microplate reader. [13]
- Data Analysis: The percentage of cell viability is calculated relative to untreated control cells, and the IC50 value is determined.

## Antimicrobial Activity

Anilide derivatives exhibit a broad spectrum of antimicrobial activity against bacteria and fungi. Their mechanism of action often involves the disruption of essential cellular processes in microorganisms.

## Antibacterial Activity

Anilides have been shown to be effective against both Gram-positive and Gram-negative bacteria. The mechanism can involve the inhibition of folic acid synthesis, disruption of cell wall synthesis, or inhibition of essential enzymes.[12]

## Antifungal Activity

Several anilide derivatives have demonstrated potent antifungal activity. The specific mechanisms can vary but may involve disruption of the fungal cell membrane or inhibition of key enzymes.

## Quantitative Antimicrobial Activity Data

The following table presents the minimum inhibitory concentration (MIC) values for selected anilide derivatives against various microbial strains.

Compound	Microorganism	MIC ( $\mu\text{M}$ )	Reference
Diamide 3e	M. tuberculosis	35.8	[15]
Diamide 3f	M. tuberculosis	18.7	[15]
Diamide 3e	Enterococcus faecalis	4.66 - 35.8	[15]
Diamide 3f	Staphylococcus aureus	0.070 - 8.95	[15]

## Experimental Protocols for Antimicrobial Testing

This method is used to qualitatively assess the antimicrobial activity of a compound.[16][17]

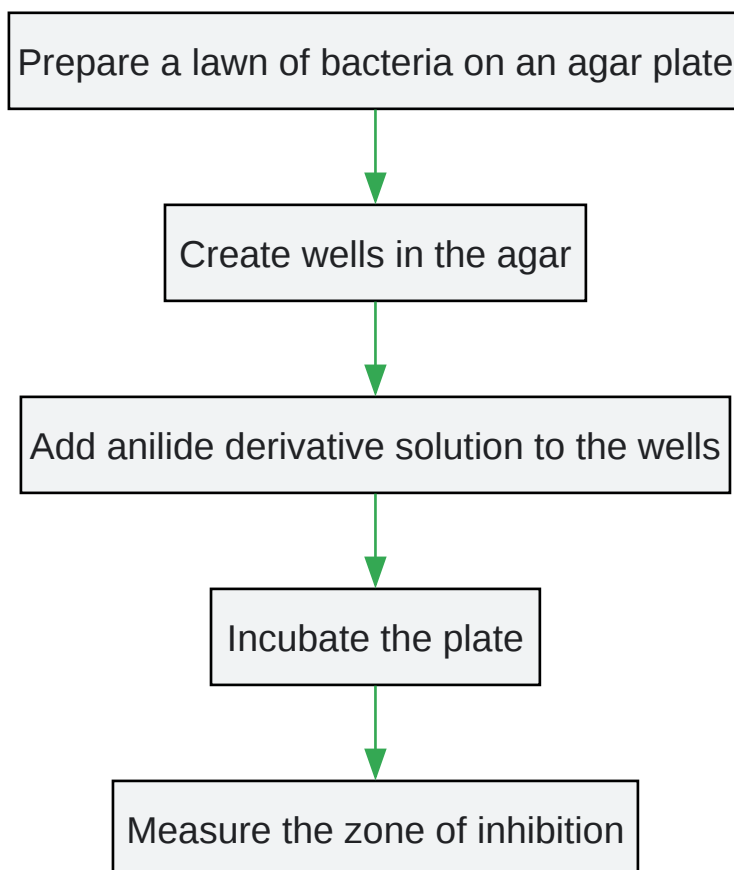

[Click to download full resolution via product page](#)

Workflow for the agar well diffusion assay.

Detailed Steps:

- Inoculation: A standardized inoculum of the test microorganism is uniformly spread onto the surface of an agar plate.[16]
- Well Creation: Wells of a specific diameter are punched into the agar.[17]
- Compound Application: A known concentration of the anilide derivative is added to each well. [16]
- Incubation: The plate is incubated under appropriate conditions for microbial growth.[16]
- Zone of Inhibition: The diameter of the clear zone around the well, where microbial growth is inhibited, is measured.[17]

This method is used to quantitatively determine the minimum inhibitory concentration (MIC) of an antimicrobial agent.[18][19]

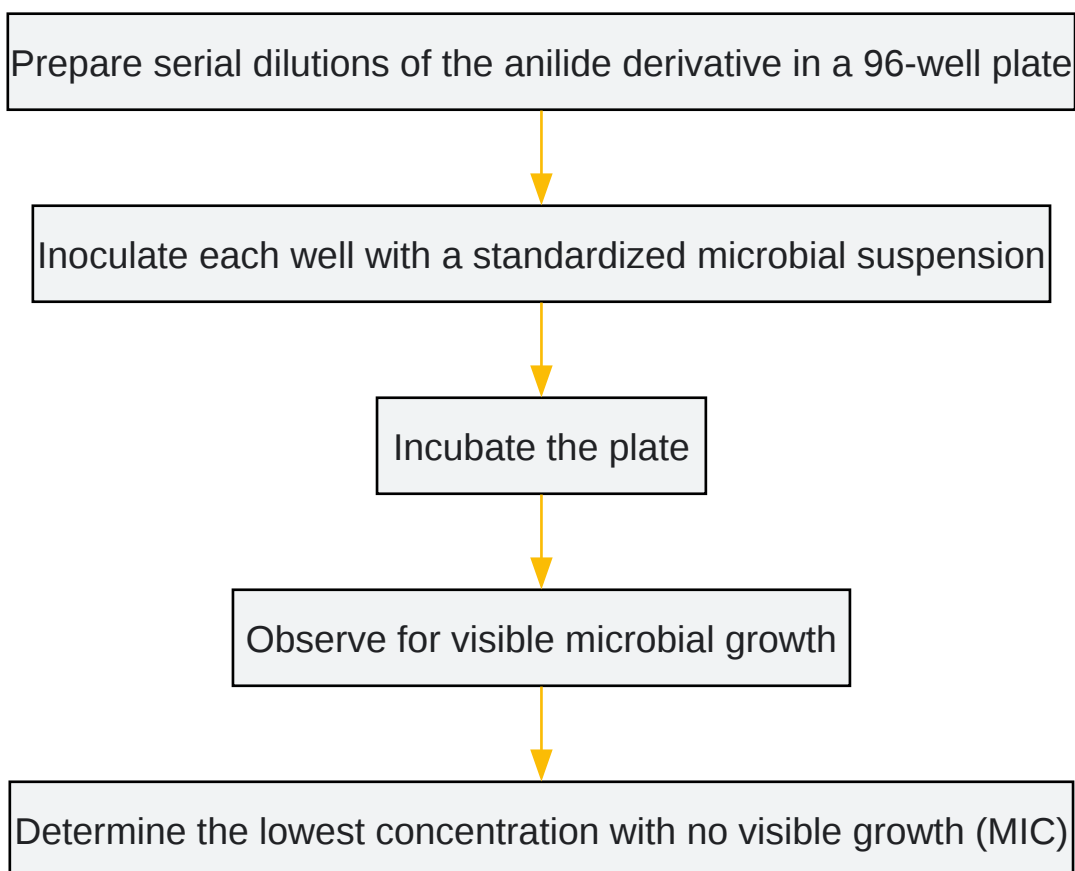

[Click to download full resolution via product page](#)

Workflow for the broth microdilution MIC assay.

Detailed Steps:

- Serial Dilution: Two-fold serial dilutions of the anilide derivative are prepared in a 96-well microtiter plate containing broth medium.[14]
- Inoculation: Each well is inoculated with a standardized suspension of the test microorganism.[18]
- Incubation: The plate is incubated for 18-24 hours at an appropriate temperature.[18]
- MIC Determination: The MIC is the lowest concentration of the compound at which no visible growth of the microorganism is observed.[19]

## Antiviral Activity

Recent studies have highlighted the potential of anilide derivatives as antiviral agents, particularly against flaviviruses.

## Quantitative Antiviral Activity Data

The following table shows the antiviral activity of some anilide derivatives.

Compound	Virus	Cell Line	EC50 ( $\mu\text{M}$ )	SI	Reference
7e	Yellow Fever Virus (YFV)	BHK-21	3.6	>27.8	[20]
6-azauridine	Yellow Fever Virus (YFV)	BHK-21	46.0	>2.2	[20]
Anidulafungin	Zika Virus (ZIKV)	-	2.08	-	[21]
Anidulafungin	Dengue Virus-2 (DENV-2)	-	3.24	-	[21]
Micafungin	SARS-CoV-2	VeroE6/TMP RSS2	26.1	>64	[21]

## Experimental Protocol: Plaque Reduction Assay

The plaque reduction assay is a standard method for evaluating the efficacy of antiviral compounds.[16][22]

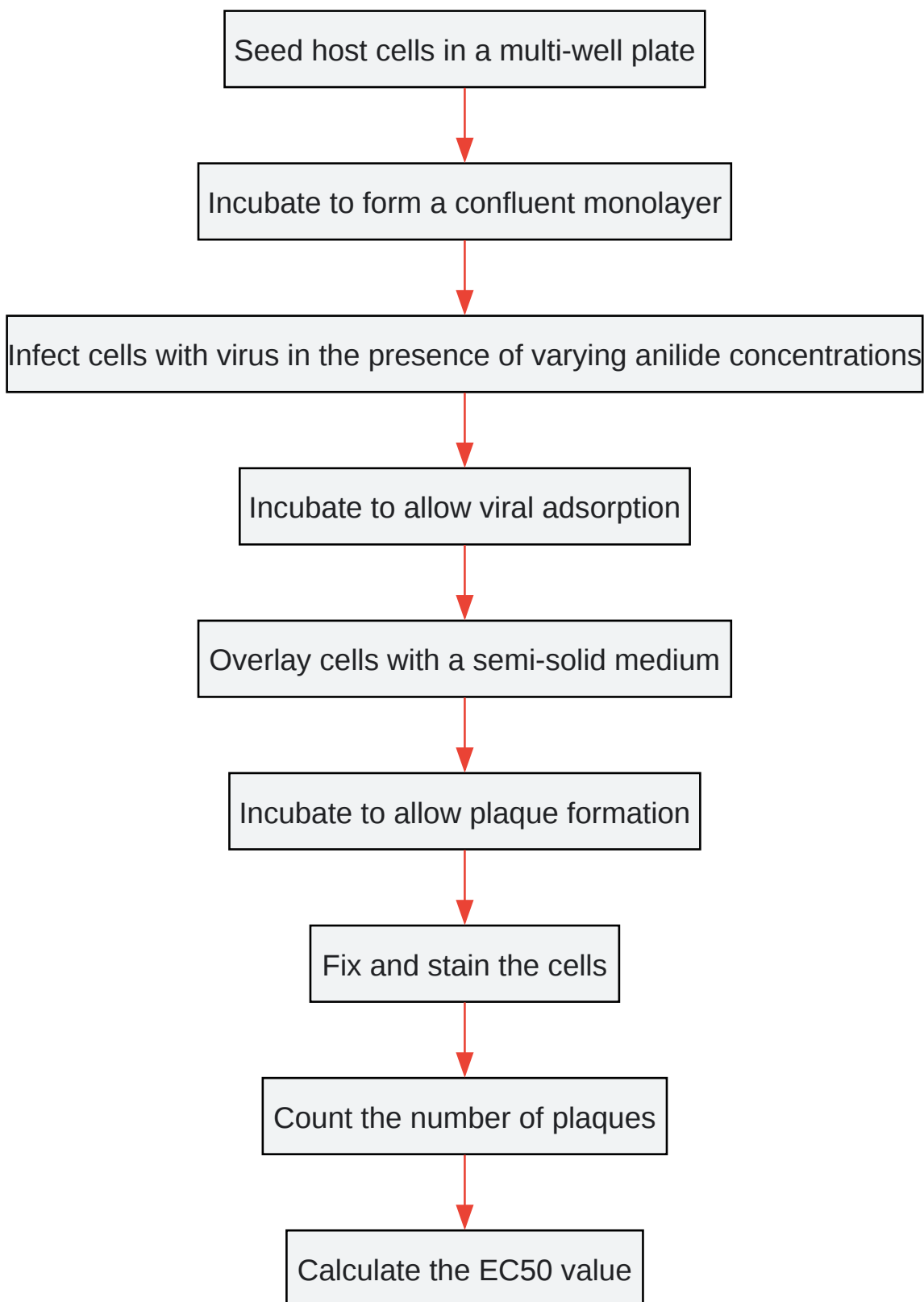

[Click to download full resolution via product page](#)

Workflow for the plaque reduction antiviral assay.

#### Detailed Steps:

- Cell Culture: A confluent monolayer of susceptible host cells is prepared in multi-well plates. [\[16\]](#)
- Infection: The cells are infected with a known amount of virus in the presence of serial dilutions of the anilide derivative. [\[16\]](#)
- Overlay: After an adsorption period, the cells are overlaid with a semi-solid medium (e.g., containing agarose) to restrict virus spread. [\[16\]](#)
- Incubation: The plates are incubated for several days to allow for the formation of plaques (zones of cell death). [\[16\]](#)
- Plaque Visualization and Counting: The cells are fixed and stained, and the number of plaques in each well is counted. [\[16\]](#)
- EC50 Determination: The effective concentration 50 (EC50), the concentration of the compound that reduces the number of plaques by 50%, is calculated.

## Local Anesthetic Activity

Anilide derivatives, such as lidocaine and bupivacaine, are widely used as local anesthetics. Their mechanism of action involves the blockade of voltage-gated sodium channels in neuronal membranes. [\[18\]](#)[\[23\]](#)

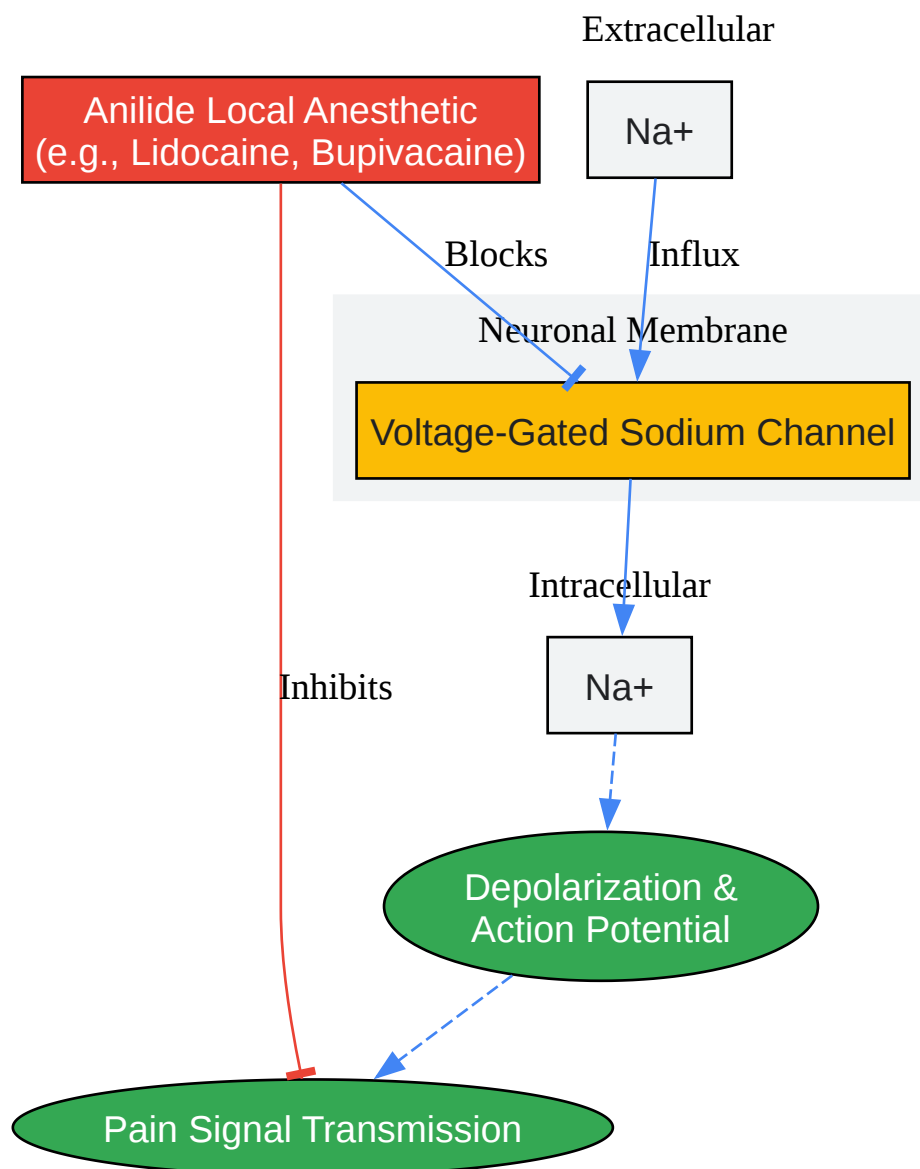

[Click to download full resolution via product page](#)

Mechanism of action of anilide local anesthetics.

By blocking sodium influx, these agents prevent the depolarization of the neuronal membrane and the propagation of action potentials, thereby blocking the sensation of pain.[18] The duration of action is influenced by factors such as lipid solubility and protein binding.[6]

## Other Biological Activities

Anilide derivatives have also been investigated for other biological activities, including:

- **Herbicidal Activity:** Some anilides act as herbicides by inhibiting enzymes in plants, such as histone deacetylase.[13][24]
- **Insecticidal Activity:** Certain anilide derivatives, particularly anthranilic diamides, target insect ryanodine receptors, leading to uncontrolled calcium release and paralysis.[9][25]

## Conclusion

Anilide derivatives represent a remarkably versatile and privileged scaffold in the design and development of new therapeutic agents and other biologically active compounds. Their straightforward synthesis allows for extensive structural modifications, leading to a broad spectrum of activities. The continued exploration of their mechanisms of action and structure-activity relationships will undoubtedly pave the way for the discovery of novel and more effective anilide-based drugs and agrochemicals. This technical guide provides a solid foundation of data and methodologies to support these future research endeavors.

### *Need Custom Synthesis?*

*BenchChem offers custom synthesis for rare earth carbides and specific isotopic labeling.*

*Email: [info@benchchem.com](mailto:info@benchchem.com) or [Request Quote Online](#).*

## References

- [1. faculty.uobasrah.edu.iq](https://faculty.uobasrah.edu.iq) [faculty.uobasrah.edu.iq]
- [2. Cytopathic Effect Assay and Plaque Assay to Evaluate in vitro Activity of Antiviral Compounds Against Human Coronaviruses 229E, OC43, and NL63 - PMC](#) [pmc.ncbi.nlm.nih.gov]
- [3. Chemical substructures that enrich for biological activity - PMC](#) [pmc.ncbi.nlm.nih.gov]
- [4. Lidocaine: Structure & Mechanism of Action - Video | Study.com](#) [study.com]
- [5. Lidocaine - Wikipedia](#) [en.wikipedia.org]
- [6. pharmacyfreak.com](#) [pharmacyfreak.com]
- [7. researchgate.net](#) [researchgate.net]
- [8. m.youtube.com](#) [m.youtube.com]

- 9. Synthesis, Structure and Insecticidal Activities of Some Novel Amides Containing N-Pyridylpyrazole Moieties - PMC [[pmc.ncbi.nlm.nih.gov](https://pubmed.ncbi.nlm.nih.gov)]
- 10. Enzyme Inhibitors as Multifaceted Tools in Medicine and Agriculture - PubMed [[pubmed.ncbi.nlm.nih.gov](https://pubmed.ncbi.nlm.nih.gov)]
- 11. Synthesis, structure-activity relationships and preliminary mechanism study of N-benzylideneaniline derivatives as potential TLR2 inhibitors - PubMed [[pubmed.ncbi.nlm.nih.gov](https://pubmed.ncbi.nlm.nih.gov)]
- 12. [benchchem.com](https://www.benchchem.com) [[benchchem.com](https://www.benchchem.com)]
- 13. [researchgate.net](https://www.researchgate.net) [[researchgate.net](https://www.researchgate.net)]
- 14. Broth Microdilution In Vitro Screening: An Easy and Fast Method to Detect New Antifungal Compounds - PMC [[pmc.ncbi.nlm.nih.gov](https://pubmed.ncbi.nlm.nih.gov)]
- 15. [researchgate.net](https://www.researchgate.net) [[researchgate.net](https://www.researchgate.net)]
- 16. [benchchem.com](https://www.benchchem.com) [[benchchem.com](https://www.benchchem.com)]
- 17. Bupivacaine - Wikipedia [[en.wikipedia.org](https://en.wikipedia.org)]
- 18. Lidocaine hydrochloride: mechanism of action, pharmacokinetics and activities\_Chemicalbook [[chemicalbook.com](https://www.chemicalbook.com)]
- 19. A Practical Guide to Antifungal Susceptibility Testing - PMC [[pmc.ncbi.nlm.nih.gov](https://pubmed.ncbi.nlm.nih.gov)]
- 20. [pubs.acs.org](https://pubs.acs.org) [[pubs.acs.org](https://pubs.acs.org)]
- 21. Biological activity of 2-hydroxythiobenzanilides and related compounds - PubMed [[pubmed.ncbi.nlm.nih.gov](https://pubmed.ncbi.nlm.nih.gov)]
- 22. Antiviral assay -Antimicrobial assay -Microbiology-BIO-PROTOCOL [[bio-protocol.org](https://www.bio-protocol.org)]
- 23. What is the mechanism of Bupivacaine Hydrochloride? [[synapse.patsnap.com](https://www.synapse.patsnap.com)]
- 24. One-pot synthesis of anilides, herbicidal activity and molecular docking study - PubMed [[pubmed.ncbi.nlm.nih.gov](https://pubmed.ncbi.nlm.nih.gov)]
- 25. Novel Fluorinated Aniline Anthranilic Diamides Improved Insecticidal Activity Targeting the Ryanodine Receptor - PubMed [[pubmed.ncbi.nlm.nih.gov](https://pubmed.ncbi.nlm.nih.gov)]
- To cite this document: BenchChem. [Anilide Derivatives: A Comprehensive Technical Guide to Their Biological Significance]. BenchChem, [2026]. [Online PDF]. Available at: [<https://www.benchchem.com/product/b1216903/docs#anilide-derivatives-a-comprehensive-technical-guide-to-their-biological-significance>]

---

**Disclaimer & Data Validity:**

The information provided in this document is for Research Use Only (RUO) and is strictly not intended for diagnostic or therapeutic procedures. While BenchChem strives to provide accurate protocols, we make no warranties, express or implied, regarding the fitness of this product for every specific experimental setup.

**Technical Support:** The protocols provided are for reference purposes. Unsure if this reagent suits your experiment?

**Need Industrial/Bulk Grade?** [Request Custom Synthesis Quote](#)

## BenchChem

Our mission is to be the trusted global source of essential and advanced chemicals, empowering scientists and researchers to drive progress in science and industry.

### Contact

Address: 3281 E Guasti Rd  
Ontario, CA 91761, United States  
Phone: (601) 213-4426  
Email: [info@benchchem.com](mailto:info@benchchem.com)

[Contact our Ph.D. Support Team for a compatibility check](#)