

# A Technical Guide to the Spectral Analysis of N-Methylhexanamide

**Author:** BenchChem Technical Support Team. **Date:** April 2026

## Compound of Interest

Compound Name: *N-Methylhexanamide*

CAS No.: 3418-05-1

Cat. No.: B1216667

[Get Quote](#)

For Researchers, Scientists, and Drug Development Professionals

This in-depth technical guide provides a comprehensive overview of the spectral data for **N-Methylhexanamide**, a fatty amide with relevance in various chemical and biological studies. This document presents a detailed analysis of its Nuclear Magnetic Resonance (NMR), Infrared (IR), and Mass Spectrometry (MS) data, complete with experimental protocols and a visual representation of its mass spectral fragmentation pathway.

## Spectral Data Summary

The following tables summarize the key quantitative data obtained from the spectral analysis of **N-Methylhexanamide**.

## Nuclear Magnetic Resonance (NMR) Spectroscopy

<sup>1</sup>H NMR (Proton NMR) Data

Chemical Shift ( $\delta$ ) ppm	Multiplicity	Integration	Coupling Constant (J) Hz	Assignment
5.90	br s	1H	-	NH
2.76	d	3H	4.8	N-CH <sub>3</sub>
2.13	t	2H	7.8	-CH <sub>2</sub> -C=O
1.5-1.6	m	2H	-	-CH <sub>2</sub> -CH <sub>2</sub> -C=O
1.2-1.3	m	4H	-	-CH <sub>2</sub> -CH <sub>2</sub> -CH <sub>2</sub> -
0.85	t	3H	7.0	-CH <sub>3</sub>

Solvent: CDCl<sub>3</sub>, Frequency: 400 MHz[1]

<sup>13</sup>C NMR (Carbon-13 NMR) Data

Chemical Shift ( $\delta$ ) ppm	Assignment
173.5	C=O
36.5	-CH <sub>2</sub> -C=O
31.4	-CH <sub>2</sub> -CH <sub>2</sub> -C=O
26.2	N-CH <sub>3</sub>
25.4	-CH <sub>2</sub> -CH <sub>2</sub> -CH <sub>2</sub> -
22.4	-CH <sub>2</sub> -CH <sub>3</sub>
13.9	-CH <sub>3</sub>

Note: The <sup>13</sup>C NMR data is predicted based on typical chemical shifts for similar aliphatic amides, as specific experimental data was not available in the searched literature.[2][3]

## Infrared (IR) Spectroscopy

Wavenumber (cm <sup>-1</sup> )	Intensity	Assignment
~3300	Strong, Broad	N-H Stretch
~2955, 2930, 2870	Strong	C-H Stretch (Aliphatic)
~1640	Strong	C=O Stretch (Amide I Band)
~1550	Strong	N-H Bend (Amide II Band)
~1465	Medium	C-H Bend (CH <sub>2</sub> )

Note: The IR absorption data is based on characteristic frequencies for secondary amides, as a specific peak list for **N-Methylhexanamide** was not available in the searched literature.[4][5]

## Mass Spectrometry (MS)

m/z	Relative Intensity	Proposed Fragment
129	Moderate	[M] <sup>+</sup> (Molecular Ion)
114	Low	[M - CH <sub>3</sub> ] <sup>+</sup>
100	Low	[M - C <sub>2</sub> H <sub>5</sub> ] <sup>+</sup>
86	Moderate	[M - C <sub>3</sub> H <sub>7</sub> ] <sup>+</sup>
72	Strong	[CH <sub>3</sub> NHCOCH <sub>2</sub> CH <sub>2</sub> ] <sup>+</sup> (McLafferty Rearrangement)
58	Very Strong	[CH <sub>3</sub> NH=C(OH)CH <sub>3</sub> ] <sup>+</sup> or [CH <sub>3</sub> CH <sub>2</sub> CONHCH <sub>3</sub> ] <sup>+</sup>
44	Moderate	[CH <sub>3</sub> C(OH)=NH] <sup>+</sup>
30	Moderate	[CH <sub>3</sub> NH <sub>2</sub> ] <sup>+</sup>

Note: The mass spectrometry data is inferred from typical fragmentation patterns of aliphatic amides, as specific experimental data with relative intensities was not available in the searched literature.[6][7][8]

## Mass Spectrometry Fragmentation Pathway

The fragmentation of **N-Methylhexanamide** in a mass spectrometer is primarily driven by the cleavage of bonds adjacent to the carbonyl group and the nitrogen atom, as well as characteristic rearrangements. A significant fragmentation route is the McLafferty rearrangement, which is common for carbonyl compounds with a sufficiently long alkyl chain.

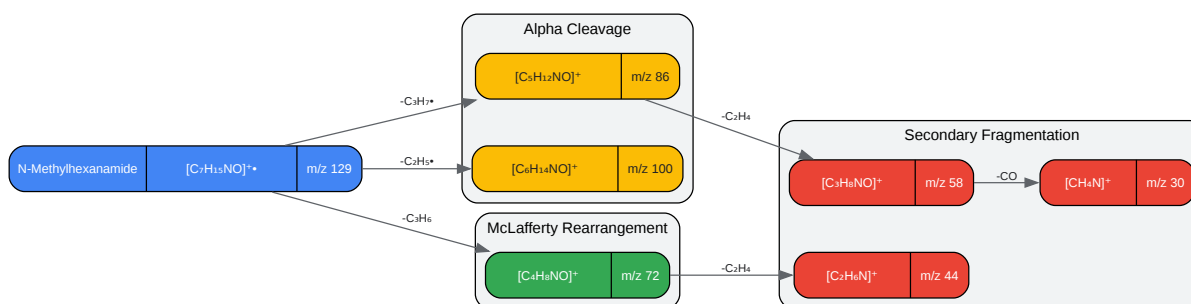

[Click to download full resolution via product page](#)

Caption: Proposed fragmentation pathway of **N-Methylhexanamide**.

## Experimental Protocols

The following sections detail generalized protocols for the acquisition of the spectral data presented. These protocols are based on standard laboratory practices for the analysis of small organic molecules.

## NMR Spectroscopy

- **Sample Preparation:** Approximately 5-10 mg of **N-Methylhexanamide** is dissolved in 0.5-0.7 mL of deuterated chloroform ( $CDCl_3$ ). The solution is then filtered through a pipette containing a small plug of glass wool directly into a 5 mm NMR tube.
- **Instrumentation:**  $^1H$  and  $^{13}C$  NMR spectra are recorded on a 400 MHz spectrometer.

- **$^1\text{H}$  NMR Acquisition:** Proton NMR spectra are acquired with a sufficient number of scans to achieve a good signal-to-noise ratio. The spectral width is set to encompass the expected range of proton chemical shifts (typically 0-12 ppm).
- **$^{13}\text{C}$  NMR Acquisition:** Carbon-13 NMR spectra are acquired with proton decoupling to simplify the spectrum to a series of singlets. A larger number of scans is typically required for  $^{13}\text{C}$  NMR due to the low natural abundance of the  $^{13}\text{C}$  isotope.
- **Data Processing:** The raw data (Free Induction Decay - FID) is Fourier transformed, phase corrected, and baseline corrected. Chemical shifts are referenced to the residual solvent peak ( $\text{CDCl}_3$  at 7.26 ppm for  $^1\text{H}$  and 77.16 ppm for  $^{13}\text{C}$ ).

## FT-IR Spectroscopy

- **Sample Preparation:** For a liquid sample like **N-Methylhexanamide**, a thin film is prepared by placing a drop of the neat liquid between two potassium bromide (KBr) or sodium chloride (NaCl) salt plates. For vapor phase analysis, the sample is gently heated to produce a vapor which is then introduced into a gas cell.
- **Instrumentation:** A Fourier Transform Infrared (FT-IR) spectrometer is used to acquire the spectrum.
- **Data Acquisition:** A background spectrum of the empty sample compartment (or the gas cell) is recorded first. The sample is then placed in the beam path, and the sample spectrum is recorded. The final spectrum is presented in terms of transmittance or absorbance as a function of wavenumber (typically 4000-400  $\text{cm}^{-1}$ ). A typical resolution is 4  $\text{cm}^{-1}$ .
- **Data Processing:** The instrument's software automatically ratios the sample spectrum to the background spectrum to remove contributions from atmospheric water and carbon dioxide.

## Gas Chromatography-Mass Spectrometry (GC-MS)

- **Sample Preparation:** A dilute solution of **N-Methylhexanamide** is prepared in a volatile organic solvent such as dichloromethane or ethyl acetate. The concentration is typically in the range of 10-100  $\mu\text{g}/\text{mL}$ .

- Instrumentation: A gas chromatograph coupled to a mass spectrometer (GC-MS) is used. The GC is equipped with a capillary column suitable for the separation of medium polarity compounds (e.g., a DB-5 or equivalent).
- GC Conditions:
  - Injector Temperature: Typically set to 250 °C.
  - Oven Temperature Program: A temperature gradient is used to ensure good separation, for example, starting at 50 °C, holding for 1-2 minutes, then ramping up to 280 °C at a rate of 10-20 °C/min.
  - Carrier Gas: Helium is used as the carrier gas at a constant flow rate.
- MS Conditions:
  - Ionization Mode: Electron Ionization (EI) at a standard energy of 70 eV.
  - Mass Analyzer: A quadrupole or time-of-flight (TOF) analyzer is used to separate the ions based on their mass-to-charge ratio (m/z).
  - Scan Range: The mass range is typically scanned from m/z 30 to 300 to detect the molecular ion and all significant fragments.
- Data Analysis: The total ion chromatogram (TIC) is used to identify the retention time of **N-Methylhexanamide**. The mass spectrum corresponding to this chromatographic peak is then extracted and analyzed to identify the molecular ion and the fragmentation pattern. Library matching (e.g., against the NIST database) can be used to confirm the identity of the compound.

### Need Custom Synthesis?

BenchChem offers custom synthesis for rare earth carbides and specific isotopic labeling.

Email: [info@benchchem.com](mailto:info@benchchem.com) or [Request Quote Online](#).

## References

- [1. rsc.org \[rsc.org\]](https://www.rsc.org)
- [2. chem.libretexts.org \[chem.libretexts.org\]](https://chem.libretexts.org)
- [3. 13C NMR Chemical Shift \[sites.science.oregonstate.edu\]](https://sites.science.oregonstate.edu)
- [4. uanlch.vscht.cz \[uanlch.vscht.cz\]](https://uanlch.vscht.cz)
- [5. DFT-Calculated IR Spectrum Amide I, II, and III Band Contributions of N-Methylacetamide Fine Components - PMC \[pmc.ncbi.nlm.nih.gov\]](https://pmc.ncbi.nlm.nih.gov)
- [6. chemguide.co.uk \[chemguide.co.uk\]](https://chemguide.co.uk)
- [7. Mass Spectrometry \[www2.chemistry.msu.edu\]](http://www2.chemistry.msu.edu)
- [8. chem.libretexts.org \[chem.libretexts.org\]](https://chem.libretexts.org)
- To cite this document: BenchChem. [A Technical Guide to the Spectral Analysis of N-Methylhexanamide]. BenchChem, [2026]. [Online PDF]. Available at: [\[https://www.benchchem.com/product/b1216667/docs#a-technical-guide-to-the-spectral-analysis-of-n-methylhexanamide\]](https://www.benchchem.com/product/b1216667/docs#a-technical-guide-to-the-spectral-analysis-of-n-methylhexanamide)

---

#### Disclaimer & Data Validity:

The information provided in this document is for Research Use Only (RUO) and is strictly not intended for diagnostic or therapeutic procedures. While BenchChem strives to provide accurate protocols, we make no warranties, express or implied, regarding the fitness of this product for every specific experimental setup.

**Technical Support:** The protocols provided are for reference purposes. Unsure if this reagent suits your experiment?

**Need Industrial/Bulk Grade?** [Request Custom Synthesis Quote](#)

## BenchChem

Our mission is to be the trusted global source of essential and advanced chemicals, empowering scientists and researchers to drive progress in science and industry.

#### Contact

Address: 3281 E Guasti Rd

Ontario, CA 91761, United States

Phone: (601) 213-4426

Email: [info@benchchem.com](mailto:info@benchchem.com)

Contact our Ph.D. Support Team for a compatibility check