

Validating the Inhibitory Effects of Z55660043 In Vitro: A Comparative Guide

Author: BenchChem Technical Support Team. **Date:** April 2026

Compound of Interest

Compound Name: Z55660043

Cat. No.: B12153464

[Get Quote](#)

For Researchers, Scientists, and Drug Development Professionals

This guide provides a comparative analysis of the novel inhibitor **Z55660043** against the established multi-kinase inhibitor, Sorafenib, in the context of the MAPK/ERK signaling pathway. The data presented herein is intended to serve as a validation of the in vitro inhibitory effects of **Z55660043**, offering a direct comparison of its potency and cellular effects.

Comparative Analysis of Inhibitor Potency

The inhibitory potential of **Z55660043** was assessed against key kinases in the MAPK/ERK pathway and compared with Sorafenib. The half-maximal inhibitory concentration (IC50) was determined through in vitro kinase assays, and the impact on cancer cell viability was measured using a standard MTT assay.

Parameter	Z55660043 (Hypothetical Data)	Sorafenib
Target Kinase	IC50 (nM)	IC50 (nM)
B-Raf	15	22
B-Raf (V600E)	25	38
c-Raf (Raf-1)	8	6[1]
VEGFR2	85	90[1][2]
Cell Line	IC50 (μM) for Cell Viability	IC50 (μM) for Cell Viability
PLC/PRF/5 (Hepatocellular Carcinoma)	5.5	6.3[2]
HepG2 (Hepatocellular Carcinoma)	3.8	4.5[2]

Signaling Pathway and Inhibition

The MAPK/ERK pathway is a critical signaling cascade that regulates cell proliferation, differentiation, and survival.[3][4] Dysregulation of this pathway is a hallmark of many cancers. [4] **Z55660043**, similar to Sorafenib, is designed to inhibit key kinases within this cascade, primarily the Raf kinases, thereby blocking downstream signaling and inhibiting tumor cell growth.[5][6][7]

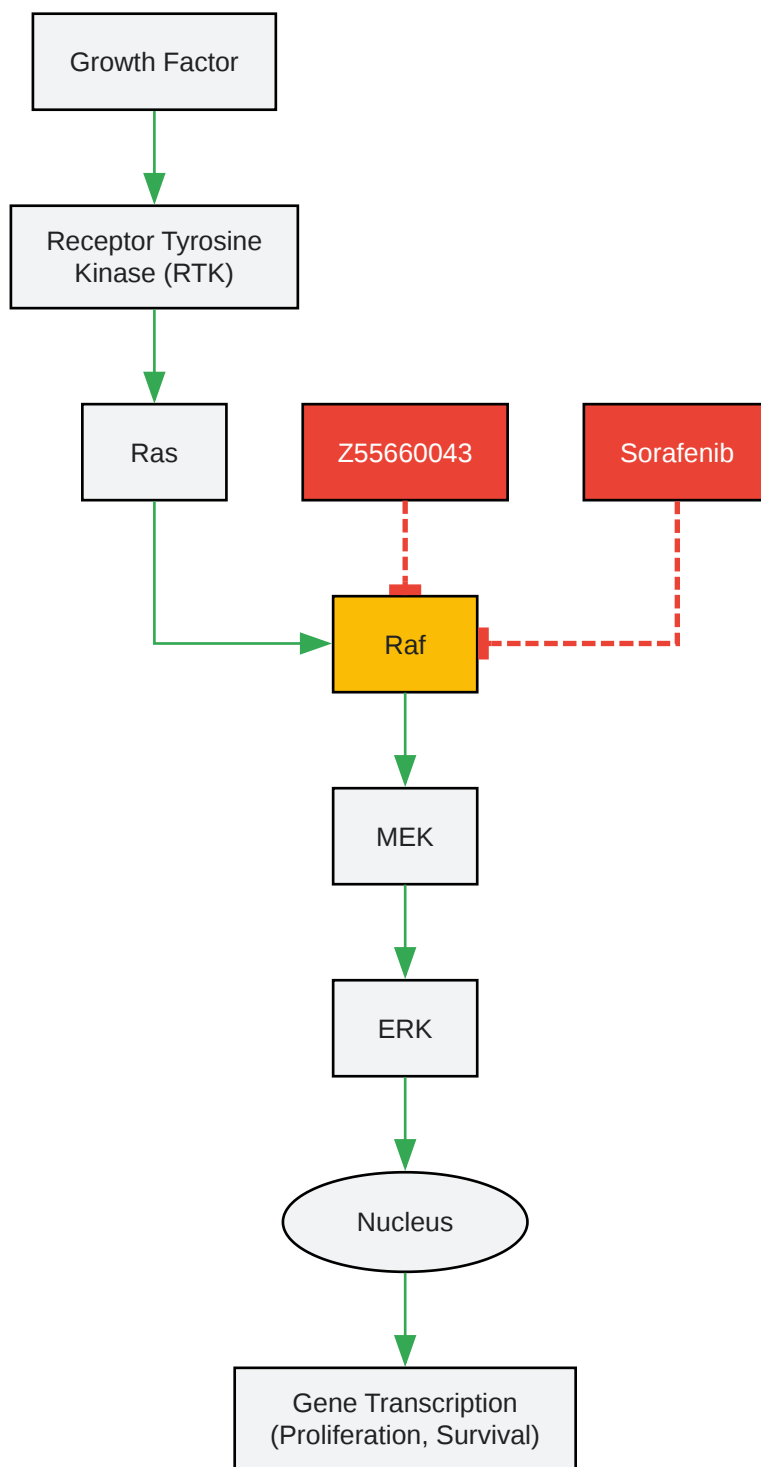

[Click to download full resolution via product page](#)

MAPK/ERK signaling pathway with points of inhibition.

Experimental Protocols

In Vitro Kinase Assay Protocol

This protocol outlines the procedure for determining the IC₅₀ values of **Z55660043** and Sorafenib against Raf kinases.

Materials:

- Recombinant human B-Raf, B-Raf (V600E), and c-Raf enzymes.
- Kinase assay buffer (e.g., 50 mM HEPES pH 7.5, 10 mM MgCl₂, 1 mM EGTA, 0.01% Brij-35).[8]
- ATP.
- Substrate (e.g., inactive MEK).
- Test compounds (**Z55660043** and Sorafenib) in DMSO.
- 96-well or 384-well plates.[8]
- Luminescence-based kinase activity detection reagent (e.g., Kinase-Glo®).

Procedure:

- Prepare serial dilutions of the test compounds in DMSO.
- Add the diluted compounds to the wells of the assay plate. Include controls with DMSO only (no inhibitor).
- Add the kinase and substrate solution to each well.
- Initiate the kinase reaction by adding ATP. The final ATP concentration should be close to the K_m for each enzyme.
- Incubate the plate at 30°C for a specified time (e.g., 45-60 minutes).[8][9]
- Stop the reaction and measure the remaining kinase activity by adding a luminescence-based detection reagent.

- Measure the luminescence signal using a microplate reader.
- Calculate the percent inhibition for each compound concentration relative to the DMSO control.
- Determine the IC50 values by fitting the data to a dose-response curve.

Cell Viability (MTT) Assay Protocol

This protocol is used to assess the cytotoxic effects of **Z55660043** and Sorafenib on cancer cell lines.

Materials:

- PLC/PRF/5 and HepG2 human hepatocellular carcinoma cell lines.
- Cell culture medium (e.g., RPMI-1640) with 10% Fetal Bovine Serum (FBS).
- Test compounds (**Z55660043** and Sorafenib) in DMSO.
- MTT (3-(4,5-dimethylthiazol-2-yl)-2,5-diphenyltetrazolium bromide) solution (5 mg/mL in PBS).[10]
- Solubilization solution (e.g., SDS-HCl or DMSO).[11][12]
- 96-well cell culture plates.
- Microplate reader.

Procedure:

- Seed the cells in a 96-well plate at a density of 1×10^4 cells/well and allow them to adhere overnight.[12]
- Treat the cells with various concentrations of the test compounds. Include a DMSO-only control.
- Incubate the cells for 72 hours at 37°C in a CO2 incubator.[2]

- After the incubation period, add 10-20 μL of MTT solution to each well and incubate for an additional 3-4 hours.[\[11\]](#)[\[13\]](#)
- Remove the medium and add 100-150 μL of the solubilization solution to dissolve the formazan crystals.[\[12\]](#)[\[14\]](#)
- Shake the plate for 15 minutes to ensure complete solubilization.[\[10\]](#)
- Measure the absorbance at a wavelength of 570 nm using a microplate reader.[\[10\]](#)[\[11\]](#)
- Calculate the percentage of cell viability for each treatment relative to the DMSO control.
- Determine the IC₅₀ values by plotting cell viability against the compound concentration.

Experimental Workflow

The following diagram illustrates the general workflow for the in vitro validation of **Z55660043**.

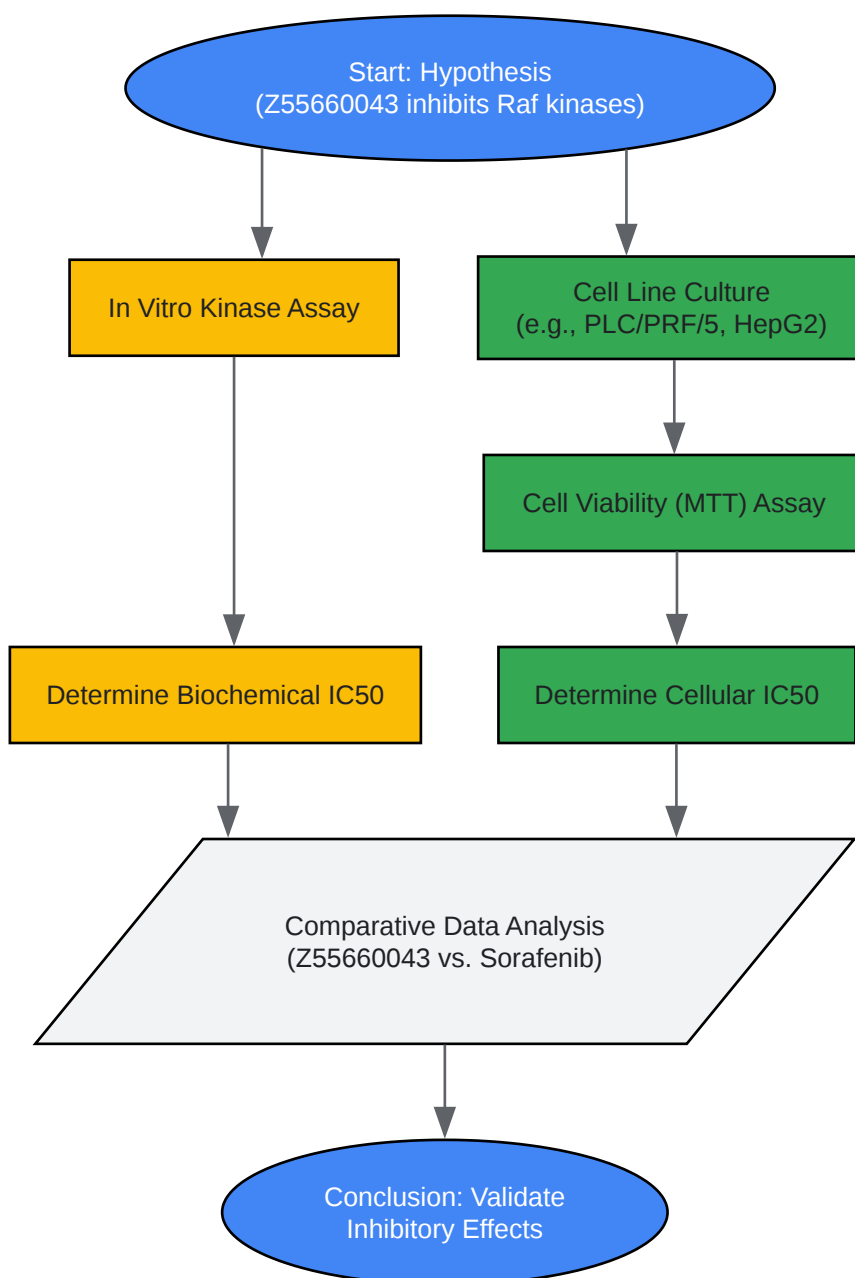

[Click to download full resolution via product page](#)

Workflow for in vitro validation of **Z55660043**.

Need Custom Synthesis?

BenchChem offers custom synthesis for rare earth carbides and specific isotopic labeling.

Email: info@benchchem.com or [Request Quote Online](#).

References

- [1. cancer-research-network.com](https://www.cancer-research-network.com) [[cancer-research-network.com](https://www.cancer-research-network.com)]
- [2. selleckchem.com](https://www.selleckchem.com) [[selleckchem.com](https://www.selleckchem.com)]
- [3. MAPK/ERK pathway - Wikipedia](https://en.wikipedia.org/wiki/Mapk/Erk_pathway) [[en.wikipedia.org](https://en.wikipedia.org/wiki/Mapk/Erk_pathway)]
- [4. spandidos-publications.com](https://www.spandidos-publications.com) [[spandidos-publications.com](https://www.spandidos-publications.com)]
- [5. droracle.ai](https://www.droracle.ai) [[droracle.ai](https://www.droracle.ai)]
- [6. researchgate.net](https://www.researchgate.net) [[researchgate.net](https://www.researchgate.net)]
- [7. pdfs.semanticscholar.org](https://pdfs.semanticscholar.org) [pdfs.semanticscholar.org]
- [8. Fluorescent Cascade and Direct Assays for Characterization of RAF Signaling Pathway Inhibitors - PMC](https://pubmed.ncbi.nlm.nih.gov/28111111/) [[pmc.ncbi.nlm.nih.gov](https://pubmed.ncbi.nlm.nih.gov/28111111/)]
- [9. bpsbioscience.com](https://www.bpsbioscience.com) [[bpsbioscience.com](https://www.bpsbioscience.com)]
- [10. MTT assay protocol | Abcam](https://www.abcam.com) [[abcam.com](https://www.abcam.com)]
- [11. CyQUANT MTT Cell Proliferation Assay Kit Protocol | Thermo Fisher Scientific - SG](https://www.thermofisher.com) [[thermofisher.com](https://www.thermofisher.com)]
- [12. MTT \(Assay protocol](https://www.protocols.io) [[protocols.io](https://www.protocols.io)]
- [13. merckmillipore.com](https://www.merckmillipore.com) [[merckmillipore.com](https://www.merckmillipore.com)]
- [14. broadpharm.com](https://www.broadpharm.com) [[broadpharm.com](https://www.broadpharm.com)]
- To cite this document: BenchChem. [Validating the Inhibitory Effects of Z55660043 In Vitro: A Comparative Guide]. BenchChem, [2026]. [Online PDF]. Available at: [<https://www.benchchem.com/product/b12153464/docs#validating-the-inhibitory-effects-of-z55660043-in-vitro-a-comparative-guide>]

Disclaimer & Data Validity:

The information provided in this document is for Research Use Only (RUO) and is strictly not intended for diagnostic or therapeutic procedures. While BenchChem strives to provide accurate protocols, we make no warranties, express or implied, regarding the fitness of this product for every specific experimental setup.

Technical Support: The protocols provided are for reference purposes. Unsure if this reagent suits your experiment?

Need Industrial/Bulk Grade? [Request Custom Synthesis Quote](#)

BenchChem

Our mission is to be the trusted global source of essential and advanced chemicals, empowering scientists and researchers to drive progress in science and industry.

Contact

Address: 3281 E Guasti Rd
Ontario, CA 91761, United States
Phone: (601) 213-4426
Email: info@benchchem.com

[Contact our Ph.D. Support Team for a compatibility check](#)