

Validating TSU-68 Target Engagement in Cells: A Comparative Guide

Author: BenchChem Technical Support Team. **Date:** April 2026

Compound of Interest

Compound Name: TSU-68
Cat. No.: B1215597

Get Quote

For Researchers, Scientists, and Drug Development Professionals

This guide provides a comprehensive comparison of methodologies for validating the cellular target engagement of **TSU-68** (also known as Orantinib or SU6668), a multi-targeted receptor tyrosine kinase (RTK) inhibitor. Understanding and confirming the direct interaction of a therapeutic compound with its intended targets inside a cell is a critical step in drug discovery, providing confidence in its mechanism of action and guiding further development.

TSU-68 is an ATP-competitive inhibitor primarily targeting Platelet-Derived Growth Factor Receptor β (PDGFR β), Fibroblast Growth Factor Receptor 1 (FGFR1), and Vascular Endothelial Growth Factor Receptor 2 (VEGFR2, also known as KDR or Flk-1).[1][2] These RTKs are crucial mediators of angiogenesis, cell proliferation, and survival, and their dysregulation is implicated in various cancers.[1][2]

This document will compare the inhibitory profile of **TSU-68** with other well-characterized multi-kinase inhibitors, detail experimental protocols for validating target engagement, and provide visual workflows to clarify these processes.

Data Presentation: Comparative Inhibitory Profiles

The following tables summarize the inhibitory potency of **TSU-68** and selected alternative compounds against their primary kinase targets. It is important to note the distinction between biochemical assays (cell-free) and cellular assays, as cellular IC50 values reflect not only kinase inhibition but also cell permeability and competition with intracellular ATP.

Table 1: Inhibitory Activity (IC50/Ki in nM) of **TSU-68** and Comparators against Primary Kinase Targets

Compound	PDGFR β	FGFR1	VEGFR2 (KDR)	Assay Type	Reference(s)
TSU-68 (Orantinib)	8 (Ki)	1200 (Ki)	2100 (Ki)	Biochemical	[1][2]
~30-100	>10000	340	Cellular	[1]	
Axitinib	1.6	-	0.2	Cellular (PAE cells)	[3]
Nintedanib	65	69	13	Biochemical	[4]
58	300-1000	46	Cellular (BA/F3)	[5]	
Regorafenib	22	202	4.2	Biochemical	[6]
90	~200	3	Cellular	[6][7]	
Sunitinib	2	>10000	80	Biochemical	[8][9]
10	-	10	Cellular (NIH-3T3)	[9]	
Sorafenib	57	580	90	Biochemical	[10]
Lenvatinib	29 (PDGFR α)	61	3.0	Biochemical	[11]
-	410	3.4	Cellular (HUVEC)	[12][13]	

Note: Dashes (-) indicate data was not readily available in the cited sources. Assay conditions and cell types can significantly influence IC50 values.

Mandatory Visualization

Signaling Pathway of TSU-68 Targets

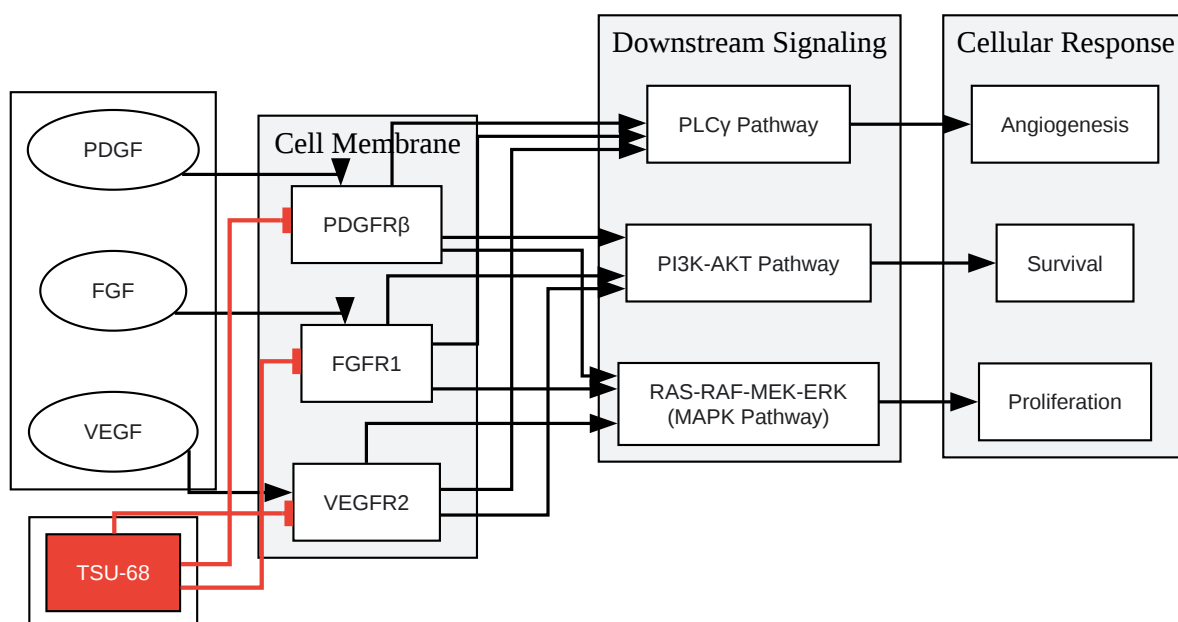

[Click to download full resolution via product page](#)

Caption: **TSU-68** inhibits PDGFR β , FGFR1, and VEGFR2 autophosphorylation.

Experimental Protocols & Visualizations

Here we detail key methodologies to validate **TSU-68** target engagement in a cellular context.

Western Blotting for Target Phosphorylation

This is the most direct and common method to assess the inhibitory action of **TSU-68** on its targets' signaling activity. A reduction in the phosphorylation of the receptor upon ligand stimulation in the presence of the inhibitor confirms target engagement.

Experimental Protocol:

- **Cell Culture and Starvation:** Culture appropriate cells (e.g., HUVECs for VEGFR2, NIH-3T3 cells overexpressing PDGFR β , or cancer cell lines with known receptor expression) to 80-90% confluency. Starve the cells in a low-serum medium (e.g., 0.5% FBS) for 18-24 hours to reduce basal receptor phosphorylation.
- **Inhibitor Treatment:** Pre-incubate the starved cells with varying concentrations of **TSU-68** (e.g., 0.01, 0.1, 1, 10 μ M) or a vehicle control (DMSO) for 1-2 hours.
- **Ligand Stimulation:** Stimulate the cells with the appropriate recombinant ligand (e.g., 50 ng/mL VEGF-A for VEGFR2, 50 ng/mL PDGF-BB for PDGFR β , or 20 ng/mL FGF2 for FGFR1) for 10-15 minutes at 37°C. Include an unstimulated control.
- **Cell Lysis:** Immediately wash the cells with ice-cold PBS and lyse them in RIPA buffer supplemented with protease and phosphatase inhibitor cocktails.
- **Protein Quantification:** Determine the protein concentration of each lysate using a BCA or Bradford assay.
- **SDS-PAGE and Western Blot:**
 - Separate equal amounts of protein (20-40 μ g) on an SDS-PAGE gel and transfer to a PVDF membrane.
 - Block the membrane with 5% BSA or non-fat milk in TBST for 1 hour.
 - Incubate the membrane overnight at 4°C with a primary antibody specific to the phosphorylated form of the target receptor (e.g., anti-p-VEGFR2 Tyr1175, anti-p-PDGFR β Tyr751).
 - Wash the membrane and incubate with an HRP-conjugated secondary antibody for 1 hour at room temperature.
 - Detect the signal using an enhanced chemiluminescence (ECL) substrate.
- **Data Analysis:**

- Strip the membrane and re-probe for the total receptor protein and a loading control (e.g., GAPDH or β -actin) to ensure equal loading.
- Quantify band intensities using densitometry software. Normalize the phosphorylated protein signal to the total protein signal. Plot the normalized data against inhibitor concentration to determine the IC50.

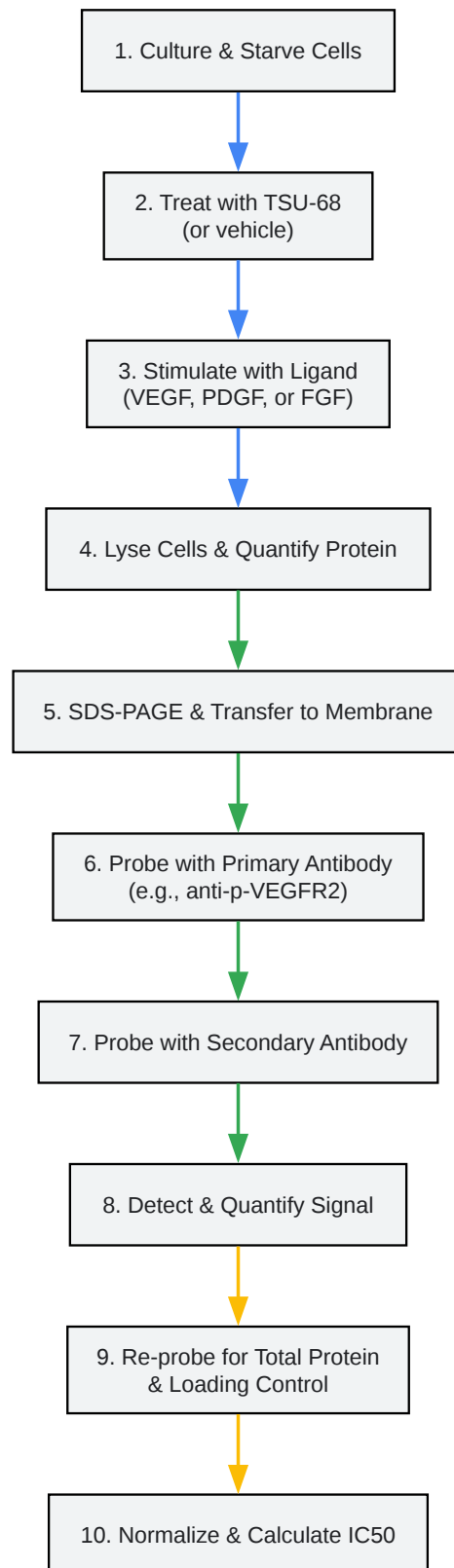

[Click to download full resolution via product page](#)

Caption: Workflow for validating target inhibition via Western Blot.

Cellular Thermal Shift Assay (CETSA)

CETSA is a biophysical method that directly assesses target engagement in intact cells. The principle is that ligand binding stabilizes the target protein, increasing its resistance to thermal denaturation.

Experimental Protocol:

- **Cell Culture and Treatment:** Culture cells to high density. Treat the cell suspension with a high concentration of **TSU-68** (e.g., 10-50 μM) or vehicle control (DMSO) for 1-2 hours at 37°C.
- **Thermal Challenge:** Aliquot the treated cell suspensions into PCR tubes. Heat the samples across a range of temperatures (e.g., 40-70°C in 2-3°C increments) for 3 minutes in a thermal cycler, followed by immediate cooling to 4°C.
- **Cell Lysis:** Lyse the cells by repeated freeze-thaw cycles (e.g., 3 cycles using liquid nitrogen and a 25°C water bath).
- **Separation of Soluble Fraction:** Centrifuge the lysates at high speed (e.g., 20,000 x g) for 20 minutes at 4°C to pellet the aggregated, denatured proteins.
- **Protein Analysis:** Carefully collect the supernatant (soluble fraction) and analyze the amount of the target protein (e.g., PDGFR β) remaining using Western blotting or ELISA.
- **Data Analysis:**
 - Quantify the amount of soluble target protein at each temperature for both the **TSU-68**-treated and vehicle-treated samples.
 - Plot the percentage of soluble protein relative to the lowest temperature point against the temperature to generate melting curves.
 - A rightward shift in the melting curve for the **TSU-68**-treated sample compared to the vehicle control indicates target stabilization and thus, engagement.

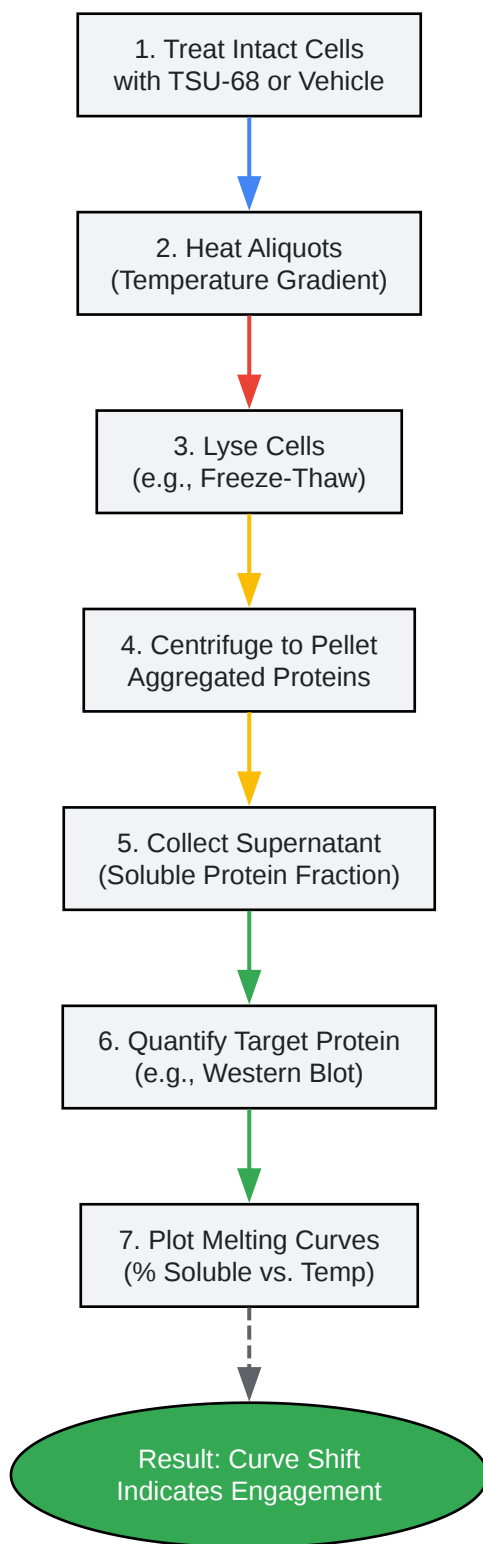

[Click to download full resolution via product page](#)

Caption: CETSA workflow to confirm direct target binding in cells.

NanoBRET™ Target Engagement Assay

NanoBRET™ is a proximity-based assay that measures compound binding at a target protein in live cells using Bioluminescence Resonance Energy Transfer (BRET). It provides quantitative affinity data in a physiological context.

Experimental Principle:

- System Components:
 - The target kinase (e.g., FGFR1) is expressed in cells as a fusion with the bright NanoLuc® luciferase.
 - A fluorescently labeled tracer compound that binds to the kinase's ATP pocket is added to the cells.
 - A cell-impermeable substrate for NanoLuc® is added.
- Energy Transfer: In the absence of a competing inhibitor, the tracer binds to the NanoLuc®-kinase fusion, bringing the fluorophore into close proximity with the luciferase. When the substrate is added, NanoLuc® emits light, which excites the tracer's fluorophore, resulting in a BRET signal.
- Competition: When an unlabeled compound like **TSU-68** is added, it competes with the tracer for binding to the kinase. This displacement separates the luciferase and the fluorophore, leading to a dose-dependent decrease in the BRET signal.
- Quantification: By measuring the BRET ratio at various concentrations of **TSU-68**, a competition binding curve can be generated to determine the intracellular IC50.

Caption: Principle of the NanoBRET™ Target Engagement Assay.

Need Custom Synthesis?

BenchChem offers custom synthesis for rare earth carbides and specific isotopic labeling.

Email: info@benchchem.com or [Request Quote Online](#).

References

- 1. [selleckchem.com](https://www.selleckchem.com) [selleckchem.com]
- 2. [apexbt.com](https://www.apexbt.com) [apexbt.com]
- 3. [selleckchem.com](https://www.selleckchem.com) [selleckchem.com]
- 4. [medchemexpress.com](https://www.medchemexpress.com) [medchemexpress.com]
- 5. Nintedanib: evidence for its therapeutic potential in idiopathic pulmonary fibrosis - PMC [pmc.ncbi.nlm.nih.gov]
- 6. Evolution of regorafenib from bench to bedside in colorectal cancer: Is it an attractive option or merely a “me too” drug? - PMC [pmc.ncbi.nlm.nih.gov]
- 7. [selleckchem.com](https://www.selleckchem.com) [selleckchem.com]
- 8. [selleckchem.com](https://www.selleckchem.com) [selleckchem.com]
- 9. [selleckchem.com](https://www.selleckchem.com) [selleckchem.com]
- 10. Sorafenib, multikinase inhibitor (CAS 284461-73-0) | Abcam [abcam.com]
- 11. Lenvatinib, a molecule with versatile application: from preclinical evidence to future development in anti-cancer treatment - PMC [pmc.ncbi.nlm.nih.gov]
- 12. Lenvatinib, an angiogenesis inhibitor targeting VEGFR/FGFR, shows broad antitumor activity in human tumor xenograft models associated with microvessel density and pericyte coverage - PMC [pmc.ncbi.nlm.nih.gov]
- 13. BioKB - Publication [biokb.lcsb.uni.lu]
- To cite this document: BenchChem. [Validating TSU-68 Target Engagement in Cells: A Comparative Guide]. BenchChem, [2026]. [Online PDF]. Available at: [https://www.benchchem.com/product/b1215597/docs#validating-tsu-68-target-engagement-in-cells-a-comparative-guide]

Disclaimer & Data Validity:

The information provided in this document is for Research Use Only (RUO) and is strictly not intended for diagnostic or therapeutic procedures. While BenchChem strives to provide accurate protocols, we make no warranties, express or implied, regarding the fitness of this product for every specific experimental setup.

Technical Support: The protocols provided are for reference purposes. Unsure if this reagent suits your experiment?

Need Industrial/Bulk Grade? [Request Custom Synthesis Quote](#)

BenchChem

Our mission is to be the trusted global source of essential and advanced chemicals, empowering scientists and researchers to drive progress in science and industry.

Contact

Address: 3281 E Guasti Rd
Ontario, CA 91761, United States
Phone: (601) 213-4426
Email: info@benchchem.com

[Contact our Ph.D. Support Team for a compatibility check](#)