

Technical Support Center: TSU-68 Off-Target Effects in Kinase Assays

Author: BenchChem Technical Support Team. **Date:** April 2026

Compound of Interest

Compound Name: TSU-68
Cat. No.: B1215597

[Get Quote](#)

This technical support center provides guidance for researchers, scientists, and drug development professionals utilizing **TSU-68** (Orantinib, SU6668) in kinase assays. Below you will find frequently asked questions (FAQs), troubleshooting guides, and detailed experimental protocols to address common challenges related to off-target effects.

Frequently Asked Questions (FAQs)

Q1: What are the primary and known off-targets of **TSU-68**?

A1: **TSU-68** is a multi-targeted tyrosine kinase inhibitor. Its primary targets include Platelet-Derived Growth Factor Receptor β (PDGFR β), Fibroblast Growth Factor Receptor 1 (FGFR1), and Vascular Endothelial Growth Factor Receptor 1 (VEGFR1, also known as Flt-1) and VEGFR2 (KDR).[1][2][3] Known off-targets with notable activity include Aurora kinases B and C and the Stem Cell Factor Receptor (c-kit).[4][5]

Q2: Against which kinases has **TSU-68** shown minimal or no activity?

A2: In cell-free assays, **TSU-68** has demonstrated little to no inhibitory activity against Insulin-like Growth Factor-1 Receptor (IGF-1R), Met, Src, Lck, Zap70, Abl, and Cyclin-Dependent

Kinase 2 (CDK2).[1][6] It also does not inhibit the Epidermal Growth Factor Receptor (EGFR).
[1][2]

Q3: My results in a cell-based assay are inconsistent with the biochemical assay data for **TSU-68**. What could be the cause?

A3: Discrepancies between biochemical and cell-based assays are common. Several factors can contribute to this:

- **Cellular ATP Concentration:** Biochemical assays are often performed at ATP concentrations significantly lower than the millimolar concentrations found within cells. As **TSU-68** is an ATP-competitive inhibitor, its apparent potency can be lower in a cellular environment.
- **Cellular Uptake and Efflux:** The compound's ability to penetrate the cell membrane and its potential removal by efflux pumps can influence its intracellular concentration and, consequently, its efficacy.
- **Off-Target Effects:** In a cellular context, the observed phenotype may be a result of **TSU-68** acting on multiple kinases within a signaling network, leading to complex downstream effects not observable in a purified biochemical assay.
- **Compensatory Signaling:** Cells can adapt to the inhibition of a specific kinase by activating compensatory signaling pathways, which might mask the effect of the inhibitor on its primary target.

Q4: How can I confirm that the observed cellular phenotype is due to the inhibition of the intended target and not an off-target effect?

A4: To validate that a phenotype is on-target, consider the following experiments:

- **Rescue Experiments:** Re-introduce a form of the target kinase that is resistant to **TSU-68**. If the phenotype is reversed, it strongly suggests on-target activity.
- **Structurally Unrelated Inhibitors:** Use a different inhibitor with a distinct chemical scaffold that targets the same kinase. If this inhibitor recapitulates the phenotype, it provides further evidence for an on-target effect.

- Knockdown/Knockout Models: Use techniques like siRNA, shRNA, or CRISPR to reduce or eliminate the expression of the target kinase. If this phenocopies the effect of **TSU-68**, it supports an on-target mechanism.

Troubleshooting Guides

Issue 1: Higher IC50 Value in Cellular Assays Compared to Biochemical Assays

- Potential Cause: High intracellular ATP concentration competing with the ATP-competitive inhibitor **TSU-68**.
- Troubleshooting Steps:
 - Confirm Target Engagement: Utilize a cellular thermal shift assay (CETSA) to verify that **TSU-68** is binding to its intended target within the cell.
 - Optimize Inhibitor Concentration: Perform a dose-response curve over a wide range of **TSU-68** concentrations to determine the optimal concentration for your cell line and assay.
 - Evaluate ATP-Competitive Nature: In your biochemical assay, vary the ATP concentration to confirm the competitive nature of **TSU-68** and to better model the cellular environment.

Issue 2: Unexpected Cellular Toxicity at Concentrations Intended for Target Inhibition

- Potential Cause: Inhibition of off-target kinases that are critical for cell survival in your specific cell model.
- Troubleshooting Steps:
 - Perform a Broad Kinase Screen: If possible, profile **TSU-68** against a comprehensive kinase panel to identify potential off-targets that could be responsible for the toxicity.
 - Lower the Concentration: Determine the lowest effective concentration that inhibits the primary target without causing significant cell death.
 - Analyze Apoptosis Markers: Use assays such as Annexin V staining or caspase-3 cleavage to determine if the observed cell death is due to apoptosis.

Issue 3: Inconsistent Phosphorylation Levels of Downstream Substrates

- Potential Cause: Transient phosphorylation events or activation of compensatory signaling pathways.
- Troubleshooting Steps:
 - Optimize Time Course: The phosphorylation of downstream targets can be rapid and transient. Perform a time-course experiment to identify the optimal time point for observing the inhibitory effect of **TSU-68**.
 - Probe for Compensatory Pathways: Use western blotting to investigate the activation of known compensatory pathways (e.g., p-AKT, p-ERK) that might be activated in response to target inhibition.
 - Ensure Proper Lysis Conditions: Use lysis buffers containing fresh protease and phosphatase inhibitors to preserve the phosphorylation status of your proteins of interest.

Quantitative Data

Table 1: In Vitro Inhibitory Activity of **TSU-68** against Primary Target Kinases

| Kinase Target | Assay Type | Inhibition Value (K _i) | Inhibition Value (IC ₅₀) | Reference(s) |
|--------------------|---------------------------------|------------------------------------|--------------------------------------|--------------|
| PDGFRβ | Cell-free autophosphorylation | 8 nM | 60 nM | [1],[5] |
| FGFR1 | Cell-free trans-phosphorylation | 1.2 μM | 3.0 μM | [1],[2],[5] |
| VEGFR1 (Flt-1) | Cell-free trans-phosphorylation | 2.1 μM | - | [1],[2] |
| VEGFR2 (KDR/Flk-1) | Cell-free trans-phosphorylation | - | 2.4 μM | [5] |

Table 2: In Vitro Inhibitory Activity of **TSU-68** against Known Off-Target Kinases

| Kinase Target | Assay Type | Inhibition Value (IC ₅₀) | Reference(s) |
|-----------------|------------------------------|--------------------------------------|--------------|
| c-kit | Cellular autophosphorylation | 100 - 1000 nM | [2] |
| Aurora kinase B | Biochemical | 35 nM | [4],[5] |
| Aurora kinase C | Biochemical | 210 nM | [4],[5] |

Experimental Protocols

Protocol 1: Biochemical Trans-Phosphorylation Kinase Assay (General)

This protocol provides a general framework for assessing the inhibitory activity of **TSU-68** against receptor tyrosine kinases like FGFR1 and VEGFR1 in a cell-free system.

Materials:

- Purified recombinant kinase (e.g., FGFR1, VEGFR1)
- Peptide substrate (e.g., poly-Glu,Tyr 4:1)
- **TSU-68** stock solution (in DMSO)
- Assay buffer (e.g., 50 mM HEPES pH 7.4, 10 mM MgCl₂, 1 mM DTT)
- [γ -³³P]ATP or unlabeled ATP for non-radiometric detection methods
- 96-well plates
- Phosphocellulose filter paper (for radiometric assay)
- Scintillation counter (for radiometric assay) or appropriate plate reader for non-radiometric methods

Procedure:

- Substrate Coating: Coat 96-well plates with the peptide substrate overnight at 4°C.

- Blocking: Wash the plates and block with a solution like 1% BSA to prevent non-specific binding.
- Serial Dilutions: Prepare serial dilutions of **TSU-68** in the assay buffer. Also, prepare a DMSO-only vehicle control.
- Kinase Reaction:
 - Add the purified kinase to each well.
 - Add the serially diluted **TSU-68** or vehicle control to the wells.
 - Pre-incubate for 10-15 minutes at room temperature.
 - Initiate the reaction by adding ATP (spiked with $[\gamma\text{-}^{33}\text{P}]\text{ATP}$ for radiometric detection).
- Incubation: Incubate the reaction at 30°C for a predetermined time, ensuring the reaction remains in the linear range.
- Termination and Detection (Radiometric):
 - Stop the reaction by adding a stop solution (e.g., phosphoric acid).
 - Transfer a portion of the reaction mixture onto phosphocellulose filter paper.
 - Wash the filter paper extensively to remove unincorporated $[\gamma\text{-}^{33}\text{P}]\text{ATP}$.
 - Measure the incorporated radioactivity using a scintillation counter.
- Data Analysis: Calculate the percentage of inhibition for each **TSU-68** concentration relative to the vehicle control. Plot the percent inhibition against the logarithm of the inhibitor concentration and fit the data to a dose-response curve to determine the IC_{50} value.

Protocol 2: Cell-Based Receptor Autophosphorylation Assay (General)

This protocol outlines a general method to assess the effect of **TSU-68** on the ligand-induced autophosphorylation of receptor tyrosine kinases (e.g., PDGFR β , c-kit) in a cellular context.

Materials:

- Cells expressing the target receptor (e.g., NIH-3T3 overexpressing PDGFR β)
- **TSU-68** stock solution (in DMSO)
- Cell culture medium
- Serum-free medium for starvation
- Ligand for receptor stimulation (e.g., PDGF, SCF)
- Ice-cold Phosphate-Buffered Saline (PBS)
- Lysis buffer (e.g., RIPA buffer) with protease and phosphatase inhibitors
- BCA Protein Assay Kit
- SDS-PAGE and Western blot reagents
- Primary antibodies (phospho-specific for the receptor and total receptor)
- HRP-conjugated secondary antibody
- Chemiluminescent substrate

Procedure:

- Cell Culture and Starvation:
 - Plate cells and allow them to adhere.
 - Once the cells reach the desired confluency, starve them in serum-free medium for several hours to overnight to reduce basal receptor phosphorylation.
- Inhibitor Treatment: Treat the starved cells with various concentrations of **TSU-68** (and a vehicle control) for a specified time (e.g., 1-2 hours).

- **Ligand Stimulation:** Stimulate the cells with the appropriate ligand (e.g., PDGF) for a short period (e.g., 5-15 minutes) to induce receptor autophosphorylation.
- **Cell Lysis:**
 - Aspirate the medium and wash the cells with ice-cold PBS.
 - Add ice-cold lysis buffer to each well and incubate on ice.
 - Scrape the cells and collect the lysate.
 - Clarify the lysate by centrifugation.
- **Protein Quantification:** Determine the protein concentration of each lysate using a BCA assay.
- **Western Blotting:**
 - Normalize the protein amounts for all samples and prepare them for SDS-PAGE.
 - Separate the proteins by SDS-PAGE and transfer them to a PVDF or nitrocellulose membrane.
 - Block the membrane and probe with a primary antibody specific for the phosphorylated form of the target receptor.
 - Strip and re-probe the membrane with an antibody for the total receptor protein as a loading control.
 - Incubate with an HRP-conjugated secondary antibody and detect the signal using a chemiluminescent substrate.
- **Data Analysis:** Quantify the band intensities for the phosphorylated and total receptor. Normalize the phospho-signal to the total protein signal for each treatment condition. Compare the phosphorylation levels in **TSU-68**-treated cells to the stimulated vehicle control to determine the extent of inhibition.

Visualizations

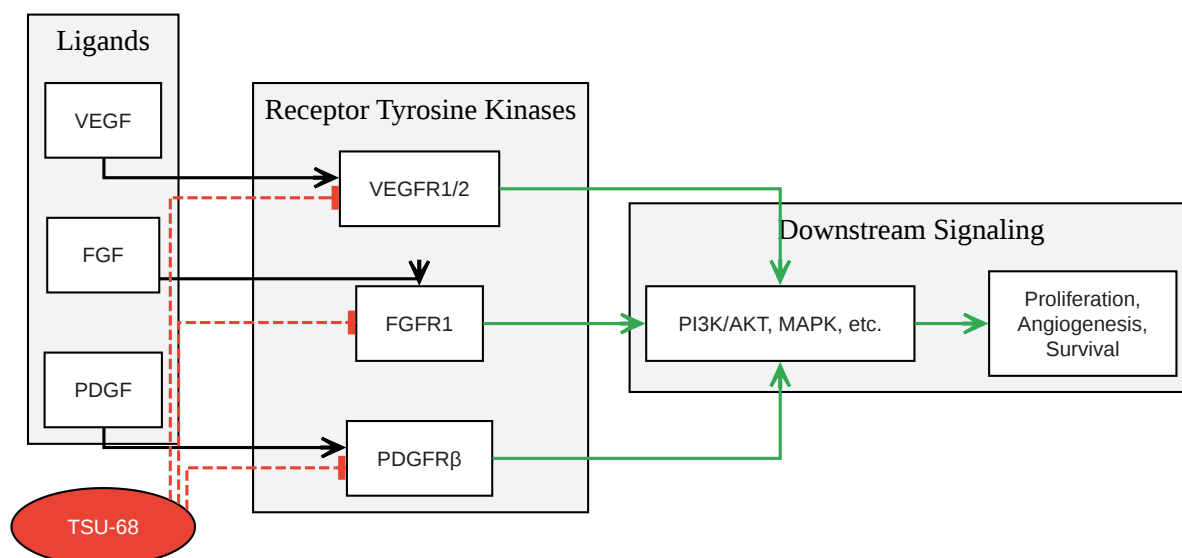

[Click to download full resolution via product page](#)

Caption: **TSU-68** inhibits key receptor tyrosine kinases in angiogenic signaling pathways.

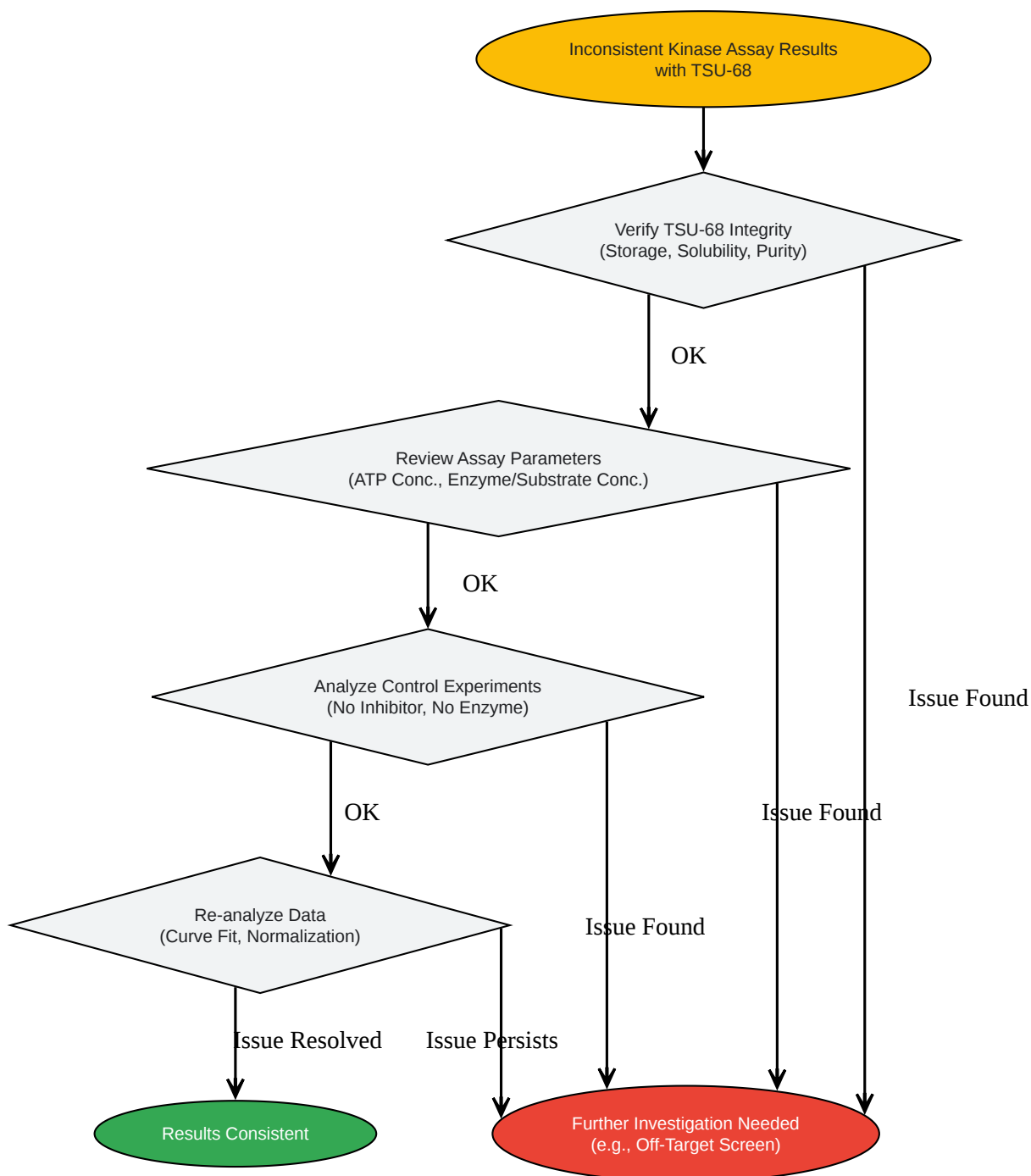

[Click to download full resolution via product page](#)

Need Custom Synthesis?

BenchChem offers custom synthesis for rare earth carbides and specific isotopic labeling.

Email: info@benchchem.com or [Request Quote Online](#).

References

- [1. selleckchem.com](https://www.selleckchem.com) [selleckchem.com]
- [2. medchemexpress.com](https://www.medchemexpress.com) [medchemexpress.com]
- [3. apexbt.com](https://www.apexbt.com) [apexbt.com]
- [4. abmole.com](https://www.abmole.com) [abmole.com]
- [5. caymanchem.com](https://www.caymanchem.com) [caymanchem.com]
- [6. adooq.com](https://www.adooq.com) [adooq.com]
- To cite this document: BenchChem. [Technical Support Center: TSU-68 Off-Target Effects in Kinase Assays]. BenchChem, [2026]. [Online PDF]. Available at: [<https://www.benchchem.com/product/b1215597/docs#technical-support-center-tsu-68-off-target-effects-in-kinase-assays>]

Disclaimer & Data Validity:

The information provided in this document is for Research Use Only (RUO) and is strictly not intended for diagnostic or therapeutic procedures. While BenchChem strives to provide accurate protocols, we make no warranties, express or implied, regarding the fitness of this product for every specific experimental setup.

Technical Support: The protocols provided are for reference purposes. Unsure if this reagent suits your experiment?

Need Industrial/Bulk Grade? [Request Custom Synthesis Quote](#)

BenchChem

Our mission is to be the trusted global source of essential and advanced chemicals, empowering scientists and researchers to drive progress in science and industry.

Contact

Address: 3281 E Guasti Rd

Ontario, CA 91761, United States

Phone: (601) 213-4426

Email: info@benchchem.com

[Contact our Ph.D. Support Team for a compatibility check](#)