

experimental setup for studying synergistic effects of (+)-camptothecin with other drugs

Author: BenchChem Technical Support Team. **Date:** December 2025

Compound of Interest

Compound Name: (+)-Camptothecin

Cat. No.: B1214933

[Get Quote](#)

Application Note & Protocol

Topic: Experimental Setup for Studying Synergistic Effects of **(+)-Camptothecin** with Other Drugs

Audience: Researchers, scientists, and drug development professionals.

Introduction

(+)-Camptothecin (CPT) is a natural pentacyclic quinoline alkaloid isolated from the bark of the *Camptotheca acuminata* tree.[1][2] It and its derivatives, such as topotecan and irinotecan, are potent anticancer agents used in the treatment of various malignancies, including colorectal, ovarian, and small cell lung cancers.[1][3] The primary mechanism of action for CPT is the inhibition of DNA topoisomerase I (Topo I).[4] Topo I alleviates torsional stress in DNA during replication and transcription by creating transient single-strand breaks.[1][2] CPT stabilizes the covalent complex between Topo I and DNA, preventing the re-ligation of the broken strand.[1][5] When a DNA replication fork collides with this stabilized complex, the single-strand break is converted into an irreversible double-strand break, which triggers cell cycle arrest and ultimately leads to apoptosis.[2][5]

Despite its efficacy, the clinical use of CPT is often limited by factors such as drug resistance and dose-limiting toxicities.[4][6] Combining CPT with other therapeutic agents is a promising strategy to overcome these challenges.[7] Synergistic combinations can enhance antitumor efficacy, allow for lower, less toxic doses of individual agents, and overcome resistance

mechanisms.[8][9] CPT has been studied in combination with a wide range of drugs, including conventional chemotherapeutics (e.g., doxorubicin, cisplatin), targeted therapies (e.g., KRAS inhibitors, CDK inhibitors), and immunotherapy agents, showing significant potential to improve therapeutic outcomes.[7][10][11]

This document provides a detailed experimental framework for evaluating the synergistic potential of **(+)-camptothecin** with other drugs in vitro.

Mechanism of Action and Synergy Rationale

CPT's unique S-phase specific cytotoxicity makes it a strong candidate for combination therapies.[5] The rationale for synergy often involves targeting complementary pathways or overcoming resistance. For example, combining CPT with a drug that induces G2/M arrest can be effective, as cells that escape CPT-induced S-phase arrest may be susceptible to the second agent. Another approach is to combine it with drugs that inhibit DNA repair pathways, thereby potentiating the DNA damage caused by CPT.

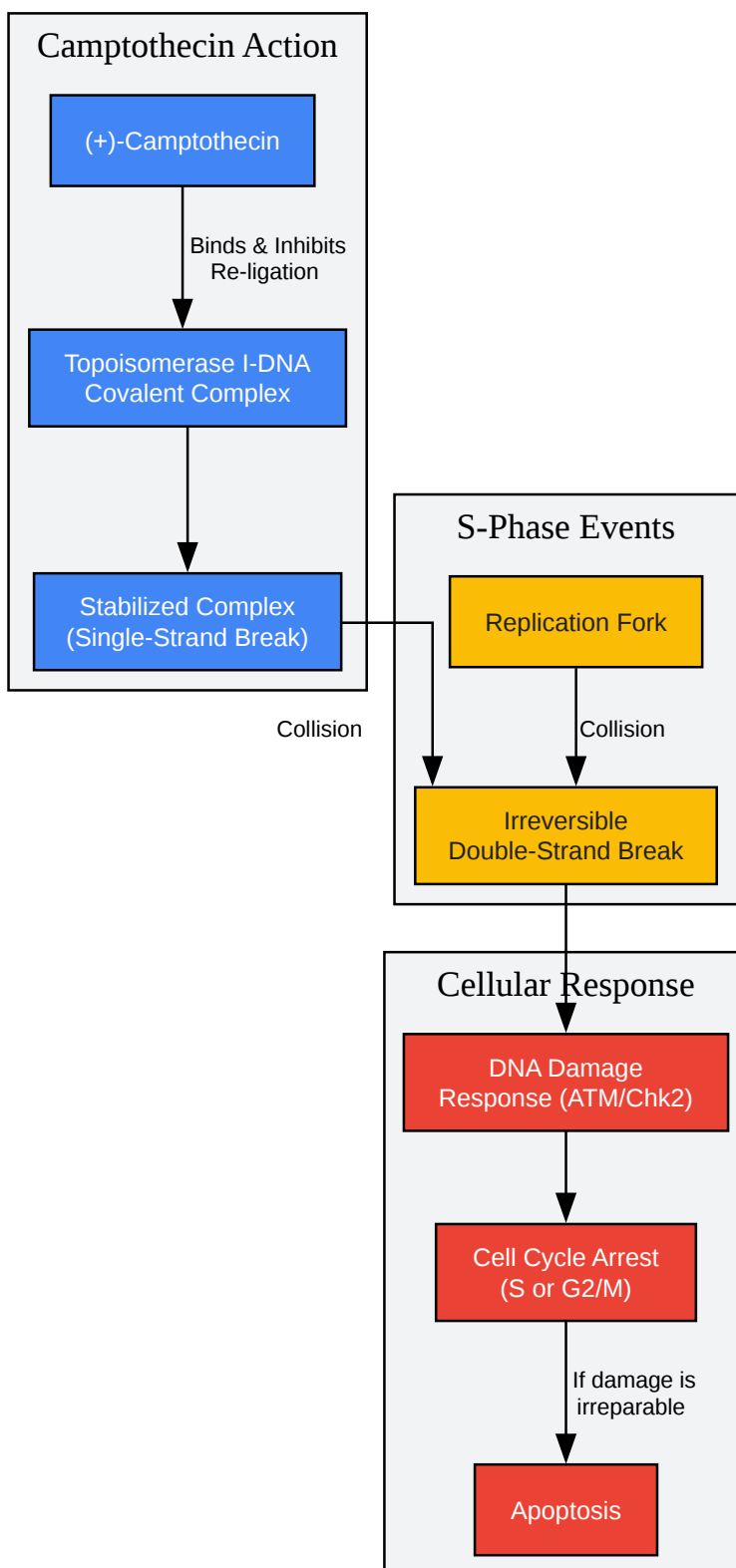

[Click to download full resolution via product page](#)

Figure 1: Mechanism of Action of (+)-Camptothecin.

Experimental Workflow

A systematic approach is required to determine and characterize drug synergy. The overall workflow involves determining the potency of individual drugs, testing them in combination to calculate synergy, and finally, using mechanistic assays to understand the biological basis of the observed interaction.

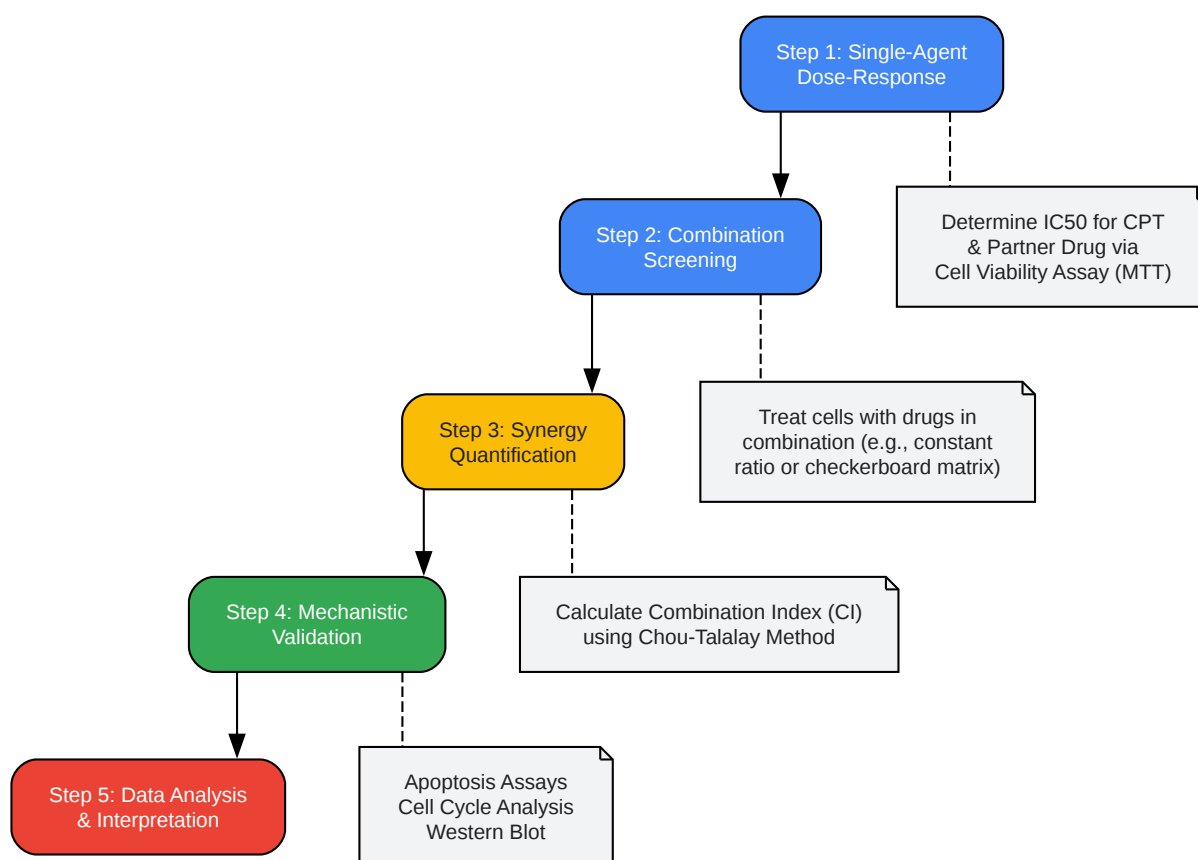

[Click to download full resolution via product page](#)

Need Custom Synthesis?

BenchChem offers custom synthesis for rare earth carbides and specific isotopic labeling.

Email: info@benchchem.com or [Request Quote Online](#).

References

- 1. bocsci.com [bocsci.com]
- 2. ar.iijournals.org [ar.iijournals.org]
- 3. Cancer Therapies Utilizing the Camptothecins: A Review of in Vivo Literature - PMC [pmc.ncbi.nlm.nih.gov]
- 4. benthamscience.com [benthamscience.com]
- 5. Mechanism of action of camptothecin - PubMed [pubmed.ncbi.nlm.nih.gov]
- 6. Mechanisms of resistance to camptothecins - PubMed [pubmed.ncbi.nlm.nih.gov]
- 7. Drug combinations of camptothecin derivatives promote the antitumor properties - PubMed [pubmed.ncbi.nlm.nih.gov]
- 8. Role of synergy and immunostimulation in design of chemotherapy combinations: An analysis of doxorubicin and camptothecin - PMC [pmc.ncbi.nlm.nih.gov]
- 9. Role of synergy and immunostimulation in design of chemotherapy combinations: An analysis of doxorubicin and camptothecin - PubMed [pubmed.ncbi.nlm.nih.gov]
- 10. Synergistic anticancer effects of camptothecin and sotorasib in KRAS-mutated pancreatic ductal adenocarcinoma - PMC [pmc.ncbi.nlm.nih.gov]
- 11. mdpi.com [mdpi.com]
- To cite this document: BenchChem. [experimental setup for studying synergistic effects of (+)-camptothecin with other drugs]. BenchChem, [2025]. [Online PDF]. Available at: [https://www.benchchem.com/product/b1214933#experimental-setup-for-studying-synergistic-effects-of-camptothecin-with-other-drugs]

Disclaimer & Data Validity:

The information provided in this document is for Research Use Only (RUO) and is strictly not intended for diagnostic or therapeutic procedures. While BenchChem strives to provide accurate protocols, we make no warranties, express or implied, regarding the fitness of this product for every specific experimental setup.

Technical Support: The protocols provided are for reference purposes. Unsure if this reagent suits your experiment? [[Contact our Ph.D. Support Team for a compatibility check](#)]

Need Industrial/Bulk Grade? [Request Custom Synthesis Quote](#)

BenchChem

Our mission is to be the trusted global source of essential and advanced chemicals, empowering scientists and researchers to drive progress in science and industry.

Contact

Address: 3281 E Guasti Rd

Ontario, CA 91761, United States

Phone: (601) 213-4426

Email: info@benchchem.com