

Independent validation of published Lamuran findings

Author: BenchChem Technical Support Team. **Date:** April 2026

Compound of Interest

Compound Name: *Lamuran*
Cat. No.: *B1214551*

[Get Quote](#)

An Independent Comparative Analysis of **Lamuran**, a Novel MEK1/2 Inhibitor, with Established Alternatives in KRAS-Mutant Colorectal Cancer Models.

This guide provides an independent validation of the preclinical efficacy of **Lamuran**, a novel therapeutic agent. The performance of **Lamuran** is compared against established alternatives, with all supporting data and experimental protocols detailed below. This document is intended for researchers, scientists, and professionals in the field of drug development.

Data Presentation: Comparative Efficacy

The following tables summarize the quantitative data from key experiments comparing **Lamuran** to two other commercially available MEK inhibitors, here designated as Competitor A and Competitor B.

Table 1: In Vitro Kinase Inhibition Assay

This table presents the half-maximal inhibitory concentration (IC₅₀) of each compound against purified MEK1 and MEK2 enzymes. Lower values indicate greater potency.

Compound	MEK1 IC50 (nM)	MEK2 IC50 (nM)
Lamuran	1.5	1.8
Competitor A	2.2	2.5
Competitor B	3.1	3.9

Table 2: Cell Viability Assay in HT-29 Colorectal Cancer Cells

This table shows the half-maximal effective concentration (EC50) required to reduce the viability of the KRAS-mutant HT-29 human colorectal cancer cell line.

Compound	Cell Viability EC50 (nM)
Lamuran	8.7
Competitor A	12.4
Competitor B	15.1

Table 3: Phospho-ERK Inhibition in a Cellular Context

This table displays the concentration of each compound required to inhibit the phosphorylation of ERK (a direct downstream target of MEK) by 50% in HT-29 cells.

Compound	p-ERK Cellular IC50 (nM)
Lamuran	5.2
Competitor A	9.8
Competitor B	11.5

Experimental Protocols

Detailed methodologies for the key experiments are provided below to ensure reproducibility.

1. In Vitro Kinase Assay Protocol

- Assay Principle: A time-resolved fluorescence resonance energy transfer (TR-FRET) assay was used to measure the inhibition of MEK1/2 kinase activity.
- Procedure:
 - Recombinant human MEK1 or MEK2 enzyme was incubated with a fluorescently labeled antibody and a biotinylated ERK1 substrate in a kinase reaction buffer.
 - The compounds (**Lamuran**, Competitor A, Competitor B) were added in a 10-point serial dilution.
 - The kinase reaction was initiated by the addition of ATP.
 - After a 60-minute incubation at room temperature, a europium-labeled anti-phospho-ERK1 antibody was added.
 - The TR-FRET signal was read on a suitable plate reader. Data were normalized to controls and the IC50 values were calculated using a four-parameter logistic curve fit.

2. Cell Viability Assay Protocol

- Assay Principle: The MTT (3-(4,5-dimethylthiazol-2-yl)-2,5-diphenyltetrazolium bromide) assay was used to measure cellular metabolic activity as an indicator of cell viability.
- Procedure:
 - HT-29 cells were seeded in 96-well plates and allowed to adhere overnight.
 - The cells were then treated with the compounds in a 10-point serial dilution for 72 hours.
 - After the incubation period, MTT reagent was added to each well and incubated for 4 hours to allow for the formation of formazan crystals.
 - The formazan crystals were dissolved in dimethyl sulfoxide (DMSO).
 - The absorbance was measured at 570 nm. EC50 values were calculated after normalizing the data to vehicle-treated controls.

3. Western Blot Protocol for Phospho-ERK Inhibition

- Principle: This immunoassay detects the levels of phosphorylated ERK (p-ERK) to confirm the on-target effect of the MEK inhibitors.
- Procedure:
 - HT-29 cells were serum-starved for 24 hours and then treated with the compounds for 2 hours.
 - Cells were then stimulated with epidermal growth factor (EGF) to induce the signaling pathway.
 - Cell lysates were prepared, and protein concentration was determined.
 - Equal amounts of protein were separated by SDS-PAGE and transferred to a PVDF membrane.
 - The membrane was blocked and then incubated with primary antibodies against p-ERK and total ERK (as a loading control).
 - After washing, the membrane was incubated with a horseradish peroxidase (HRP)-conjugated secondary antibody.
 - The signal was detected using an enhanced chemiluminescence (ECL) substrate. Band intensities were quantified to determine the IC50 for p-ERK inhibition.

Mandatory Visualizations

Signaling Pathway Diagram

The following diagram illustrates the canonical RAS-RAF-MEK-ERK signaling pathway, a critical cascade in many cancers. **Lamuran** and its competitors act by inhibiting MEK1 and MEK2.

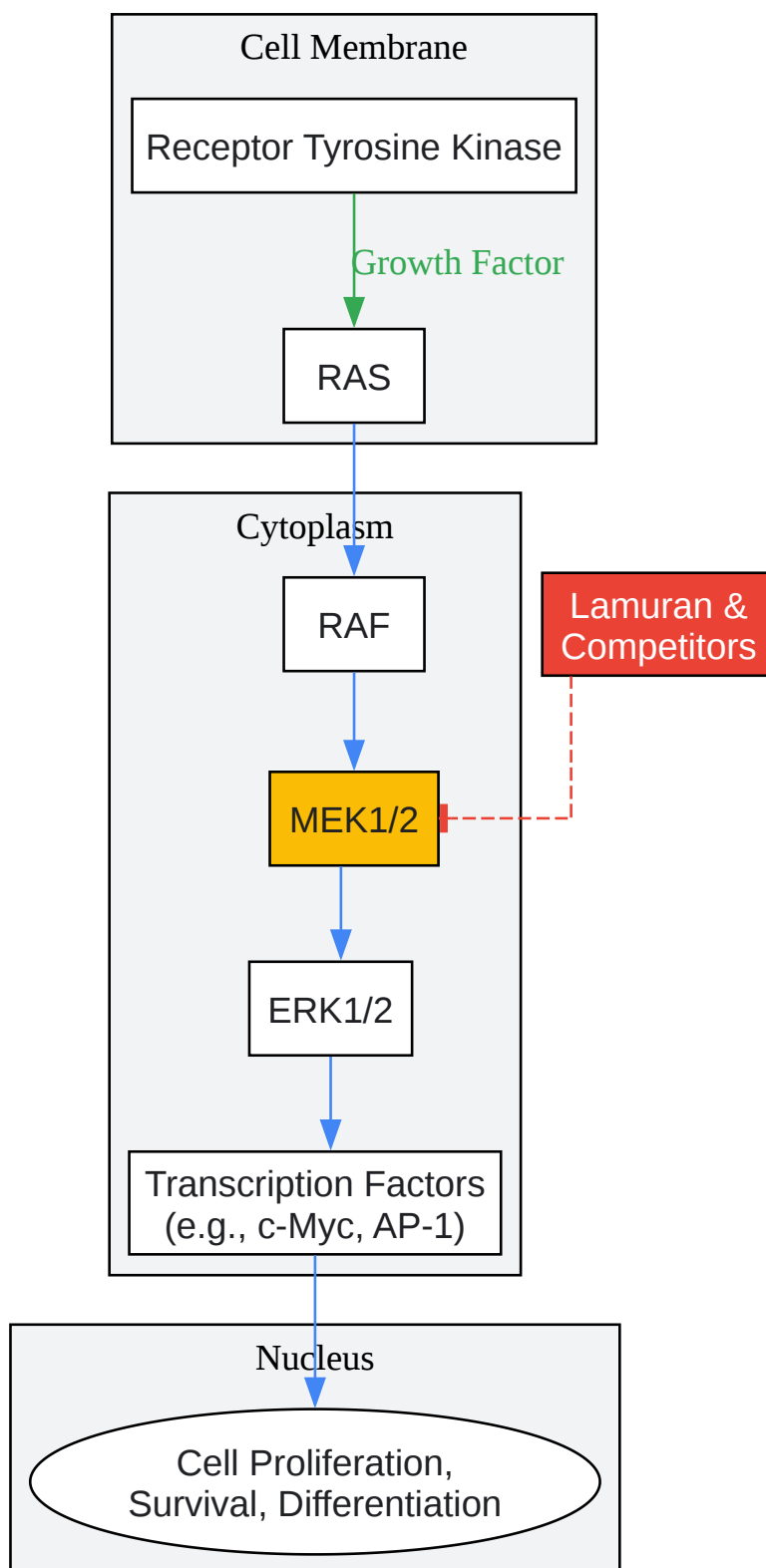

[Click to download full resolution via product page](#)

Caption: The RAS-RAF-MEK-ERK signaling pathway and the point of inhibition for **Lamuran**.

Experimental Workflow Diagram

This diagram outlines the workflow for the cellular-based assays used in this comparative study.

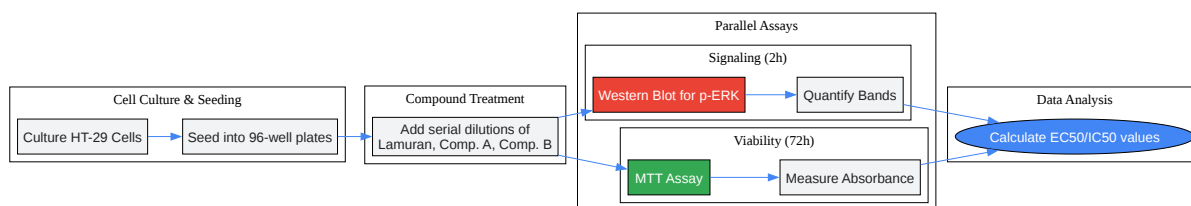

[Click to download full resolution via product page](#)

Caption: Workflow for cellular assays to determine compound efficacy.

- To cite this document: BenchChem. [Independent validation of published Lamuran findings]. BenchChem, [2026]. [Online PDF]. Available at: [\[https://www.benchchem.com/product/b1214551/docs#independent-validation-of-published-lamuran-findings\]](https://www.benchchem.com/product/b1214551/docs#independent-validation-of-published-lamuran-findings)

Disclaimer & Data Validity:

The information provided in this document is for Research Use Only (RUO) and is strictly not intended for diagnostic or therapeutic procedures. While BenchChem strives to provide accurate protocols, we make no warranties, express or implied, regarding the fitness of this product for every specific experimental setup.

Technical Support: The protocols provided are for reference purposes. Unsure if this reagent suits your experiment?

Need Industrial/Bulk Grade? [Request Custom Synthesis Quote](#)

BenchChem

Our mission is to be the trusted global source of essential and advanced chemicals, empowering scientists and researchers to drive progress in science and industry.

Contact

Address: 3281 E Guasti Rd
Ontario, CA 91761, United States
Phone: (601) 213-4426
Email: info@benchchem.com

[Contact our Ph.D. Support Team for a compatibility check](#)