

Benchmarking Interleukin-12 (IL-12) Pathway Modulators: A Comparative Guide

Author: BenchChem Technical Support Team. **Date:** April 2026

Compound of Interest

Compound Name:	RC-12
CAS No.:	6042-36-0
Cat. No.:	B1214610

[Get Quote](#)

For Researchers, Scientists, and Drug Development Professionals

This guide provides an objective comparison of Interleukin-12 (IL-12) against known inhibitors of its signaling pathway. The information is intended to support research and development efforts in immunology and oncology by presenting key performance data and detailed experimental methodologies.

Introduction to IL-12 Signaling

Interleukin-12 is a critical cytokine in the immune system, primarily involved in the differentiation of naive T cells into T helper 1 (Th1) cells.[1] It stimulates the production of interferon-gamma (IFN- γ) and tumor necrosis factor-alpha (TNF- α) from T cells and natural killer (NK) cells, playing a vital role in mediating cellular immunity against pathogens and tumors.[1] The IL-12 signaling cascade is initiated by its binding to the IL-12 receptor (IL-12R), a heterodimer of IL-12R β 1 and IL-12R β 2 subunits.[2] This binding event activates the Janus kinases, JAK2 and TYK2, which in turn phosphorylate the Signal Transducer and Activator of Transcription 4 (STAT4).[2][3] Phosphorylated STAT4 then dimerizes, translocates to the nucleus, and induces the transcription of target genes, most notably IFN- γ . [2][3]

Comparative Analysis of IL-12 Pathway Inhibitors

The IL-12 signaling pathway has been a key target for therapeutic intervention in various autoimmune diseases. Several monoclonal antibodies have been developed to inhibit this pathway, primarily by targeting the p40 subunit, which is common to both IL-12 and IL-23, or the p19 subunit of IL-23. While direct IC50 values for these inhibitors in head-to-head biochemical assays are not readily available in the public domain, their clinical efficacy provides a basis for comparison.

Inhibitor	Target	Mechanism of Action	Reported Efficacy (Clinical Remission Rates in Crohn's Disease)
Ustekinumab	IL-12/IL-23 (p40 subunit)	Monoclonal antibody that prevents IL-12 and IL-23 from binding to their receptors.[4][5]	Induction: Superior to placebo.[6] Maintenance: Maintained remission in a significant percentage of patients.[6]
Briakinumab	IL-12/IL-23 (p40 subunit)	Human monoclonal antibody that neutralizes the p40 subunit of IL-12 and IL-23.[5]	Showed some efficacy but development was halted for psoriasis due to cardiovascular safety concerns.[7][8]
Guselkumab	IL-23 (p19 subunit)	Monoclonal antibody that specifically binds to the p19 subunit of IL-23, inhibiting its interaction with the IL-23 receptor.[9]	Induction & Maintenance: Showed the highest probability of achieving clinical remission compared to placebo.[9]
Risankizumab	IL-23 (p19 subunit)	Humanized monoclonal antibody that targets the p19 subunit of IL-23.[10]	Induction: Non-inferior to ustekinumab in inducing clinical remission.[9]
Mirikizumab	IL-23 (p19 subunit)	Humanized monoclonal antibody targeting the p19 subunit of IL-23.[9]	Induction & Maintenance: Achieved the highest endoscopic remission rate compared to placebo.[9]
Apilimod Mesylate	IL-12/IL-23 Production	Small molecule inhibitor of the	Investigated in clinical trials for various

production of IL-12
and IL-23.[6]

inflammatory
conditions.[11]

IL-12 as a Pathway Activator

As a potent pro-inflammatory cytokine, IL-12 itself is the primary activator of its signaling pathway. Its efficacy in stimulating immune responses is well-documented. In vitro studies have shown that IL-12 can induce the proliferation of activated T cells and NK cells with a high potency.

Activator	Target	Mechanism of Action	EC50 for Lymphocyte Proliferation
Interleukin-12 (IL-12)	IL-12 Receptor	Binds to the IL-12R, initiating the JAK-STAT signaling cascade.[2]	8.5 ± 1.3 pM[12]

Experimental Protocols

Detailed methodologies for key experiments to benchmark IL-12 and its inhibitors are provided below.

STAT4 Phosphorylation Assay

This assay measures the phosphorylation of STAT4, a key downstream event in the IL-12 signaling pathway.

Principle: An electrochemiluminescence (ECL) based assay can be used to quantify phosphorylated STAT4 in whole cell lysates.[13][14][15]

Materials:

- MULTI-SPOT 384-well Phospho-STAT4 (Tyr693) plates[13]
- Blocking Solution (e.g., MSD Blocker A)[13]

- Complete Tris Lysis Buffer[13]
- Detection Antibody: SULFO-TAG Anti-Total STAT4 Antibody[13]
- Read Buffer T[13]
- Plate reader capable of ECL detection (e.g., SECTOR Imager)[13]

Procedure:

- Plate Preparation: Use a MULTI-SPOT 384-well plate pre-coated with anti-Phospho-STAT4 (Tyr693) antibody.[13]
- Blocking: Add 35 μ L/well of Blocking Solution and incubate with shaking for 1 hour at room temperature. Wash the plate three times with Wash Buffer.[13]
- Sample Preparation: Prepare cell lysates from cells stimulated with IL-12 in the presence or absence of inhibitors. Dilute lysates to a final concentration of 0.5 μ g/ μ L in Complete Tris Lysis Buffer.[13]
- Sample Incubation: Add 10 μ L/well of diluted lysates to the plate and incubate with shaking for 2 hours at room temperature. Wash the plate three times.[13]
- Detection: Add 10 μ L/well of SULFO-TAG Anti-Total STAT4 Detection Antibody solution and incubate with shaking for 2 hours at room temperature. Wash the plate three times.[13]
- Reading: Add 35 μ L/well of diluted Read Buffer T and analyze the plate on an ECL plate reader.[13]

Interferon-Gamma (IFN- γ) Release Assay

This assay quantifies the production of IFN- γ , a primary downstream effector cytokine of IL-12 signaling.

Principle: An Enzyme-Linked Immunosorbent Assay (ELISA) is used to measure the concentration of IFN- γ in cell culture supernatants.[16][17]

Materials:

- Anti-human IFN- γ coating antibody
- Biotinylated anti-human IFN- γ detection antibody
- Streptavidin-HRP
- TMB substrate
- Stop solution (e.g., 2N H₂SO₄)
- 96-well microplate
- Plate reader

Procedure:

- Coating: Coat a 96-well microplate with anti-human IFN- γ antibody overnight at 4°C.[16]
- Blocking: Wash the plate and block with a suitable blocking buffer for 1-2 hours at room temperature.
- Sample Incubation: Add cell culture supernatants (from cells stimulated with IL-12 +/- inhibitors) and standards to the wells and incubate for 2 hours at room temperature.[16]
- Detection Antibody: Wash the plate and add biotinylated anti-human IFN- γ detection antibody. Incubate for 1-2 hours at room temperature.
- Streptavidin-HRP: Wash the plate and add Streptavidin-HRP. Incubate for 30 minutes at room temperature in the dark.[16]
- Substrate Development: Wash the plate and add TMB substrate. Incubate for 15-30 minutes in the dark.[16]
- Reading: Stop the reaction with stop solution and read the absorbance at 450 nm.[16]

IL-12 Bioassay

This cell-based assay provides a functional readout of IL-12 activity.

Principle: A reporter cell line engineered to express the IL-12 receptor and a luciferase reporter gene under the control of an IL-12 responsive element is used. IL-12 binding to its receptor induces a luminescent signal.[18]

Materials:

- IL-12 Bioassay Cells (engineered cell line)[18]
- Recombinant human IL-12 (for standard curve)
- Bio-Glo™ Luciferase Assay System[18]
- Luminometer[18]

Procedure:

- Cell Plating: Plate the IL-12 Bioassay Cells in a 96-well or 384-well plate.[18]
- Stimulation: Add serial dilutions of recombinant IL-12 (for a standard curve) or test samples (containing potential activators or inhibitors) to the cells.[18]
- Incubation: Incubate the plate for a defined period (e.g., 4-24 hours) to allow for receptor binding and signal transduction.[18]
- Luminescence Detection: Add Bio-Glo™ Reagent to each well and measure the luminescence using a luminometer.[18]
- Data Analysis: Fit the data to a 4-parameter logistic (4PL) curve to determine EC50 or IC50 values.[18]

Visualizations

IL-12 Signaling Pathway

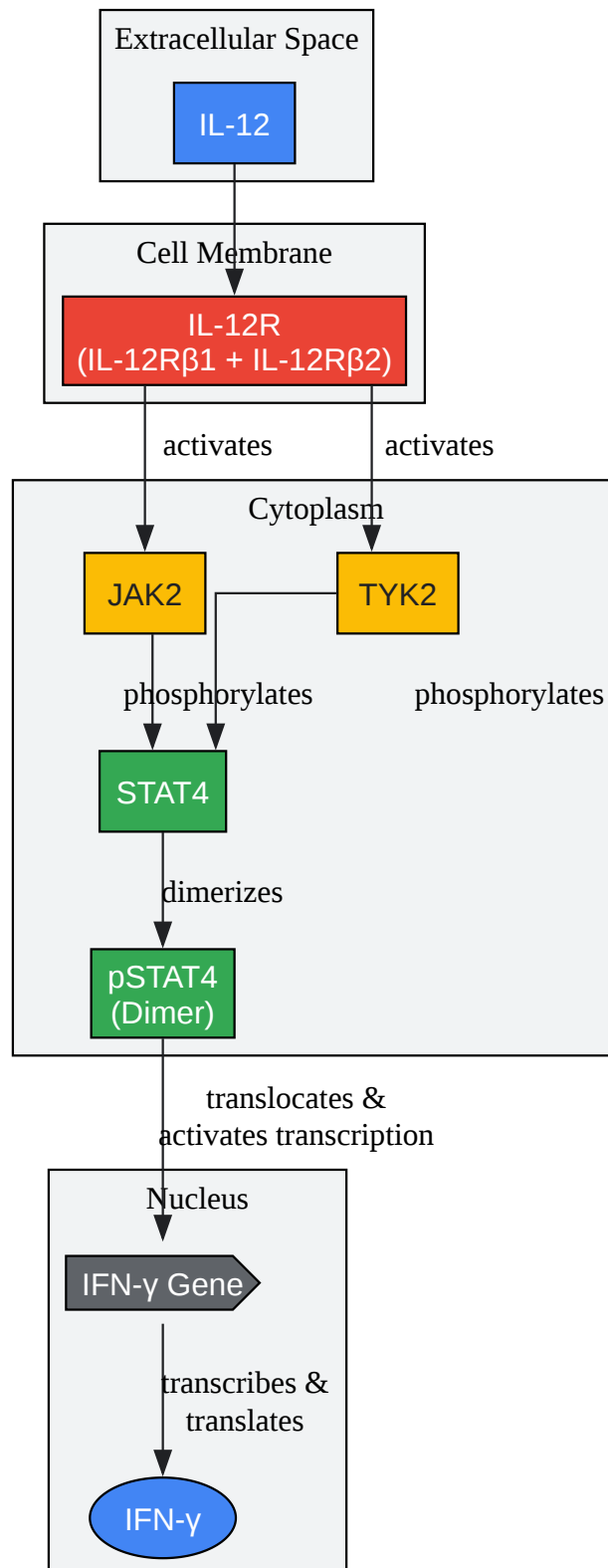

[Click to download full resolution via product page](#)

Caption: The canonical IL-12 signaling pathway leading to IFN-γ production.

Experimental Workflow for Inhibitor Benchmarking

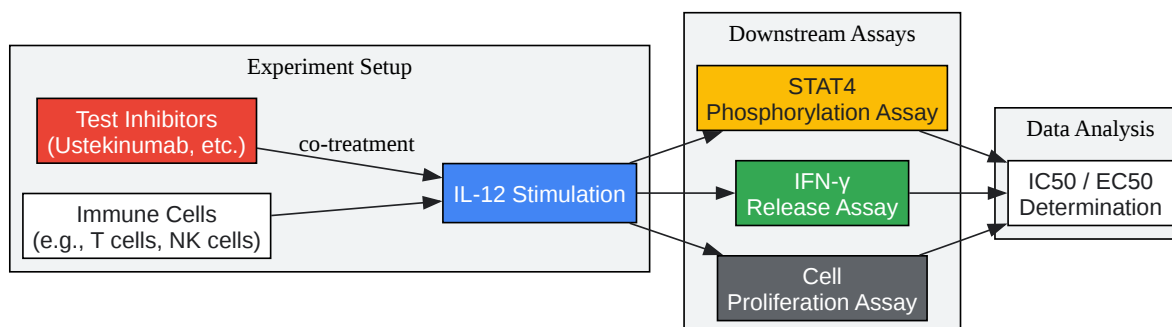

[Click to download full resolution via product page](#)

Caption: Workflow for benchmarking IL-12 pathway inhibitors.

Need Custom Synthesis?

BenchChem offers custom synthesis for rare earth carbides and specific isotopic labeling.

Email: info@benchchem.com or [Request Quote Online](#).

References

- 1. Detection of intracellular phosphorylated STAT-4 by flow cytometry - PubMed [pubmed.ncbi.nlm.nih.gov]
- 2. Immunology of IL-12: An update on functional activities and implications for disease - PMC [pmc.ncbi.nlm.nih.gov]
- 3. Interleukin-12: an update on its immunological activities, signaling and regulation of gene expression - PMC [pmc.ncbi.nlm.nih.gov]
- 4. What are IL-12 inhibitors and how do they work? [synapse.patsnap.com]
- 5. scholars.northwestern.edu [scholars.northwestern.edu]

- 6. Efficacy and Safety of IL-12/23 and IL-23 Inhibitors for Crohn's Disease: Systematic Review and Meta-Analysis - PMC [[pmc.ncbi.nlm.nih.gov](https://pubmed.ncbi.nlm.nih.gov/)]
- 7. New interleukin-23 pathway inhibitors in dermatology: ustekinumab, briakinumab, and secukinumab - PubMed [pubmed.ncbi.nlm.nih.gov]
- 8. Association of ustekinumab and briakinumab with major adverse cardiovascular events: An appraisal of meta-analyses and industry sponsored pooled analyses to date - PMC [[pmc.ncbi.nlm.nih.gov](https://pubmed.ncbi.nlm.nih.gov/)]
- 9. Comparative Efficacy of IL-12/23 and IL-23 Inhibitors for Induction and Maintenance Therapy in Moderate-to-Severe Crohn's Disease: A Systematic Review and Network Meta-Analysis - PMC [[pmc.ncbi.nlm.nih.gov](https://pubmed.ncbi.nlm.nih.gov/)]
- 10. [mayoclinic.elsevierpure.com](https://www.mayoclinic.com/elsevierpure.com) [[mayoclinic.elsevierpure.com](https://www.mayoclinic.com/elsevierpure.com)]
- 11. [precisionbusinessinsights.com](https://www.precisionbusinessinsights.com) [[precisionbusinessinsights.com](https://www.precisionbusinessinsights.com)]
- 12. Regulation of human lymphocyte proliferation by a heterodimeric cytokine, IL-12 (cytotoxic lymphocyte maturation factor) - PubMed [pubmed.ncbi.nlm.nih.gov]
- 13. [mesoscale.com](https://www.mesoscale.com) [[mesoscale.com](https://www.mesoscale.com)]
- 14. [mesoscale.com](https://www.mesoscale.com) [[mesoscale.com](https://www.mesoscale.com)]
- 15. [mesoscale.com](https://www.mesoscale.com) [[mesoscale.com](https://www.mesoscale.com)]
- 16. [protocols.io](https://www.protocols.io) [[protocols.io](https://www.protocols.io)]
- 17. Interferon gamma release assays: principles and practice | Enfermedades Infecciosas y Microbiología Clínica [[elsevier.es](https://www.elsevier.es)]
- 18. [promega.com](https://www.promega.com) [[promega.com](https://www.promega.com)]
- To cite this document: BenchChem. [Benchmarking Interleukin-12 (IL-12) Pathway Modulators: A Comparative Guide]. BenchChem, [2026]. [Online PDF]. Available at: [<https://www.benchchem.com/product/b1214610/docs#benchmarking-interleukin-12-il-12-pathway-modulators-a-comparative-guide>]

Disclaimer & Data Validity:

The information provided in this document is for Research Use Only (RUO) and is strictly not intended for diagnostic or therapeutic procedures. While BenchChem strives to provide accurate protocols, we make no warranties, express or implied, regarding the fitness of this product for every specific experimental setup.

Technical Support: The protocols provided are for reference purposes. Unsure if this reagent suits your experiment?

Need Industrial/Bulk Grade? [Request Custom Synthesis Quote](#)

BenchChem

Our mission is to be the trusted global source of essential and advanced chemicals, empowering scientists and researchers to drive progress in science and industry.

Contact

Address: 3281 E Guasti Rd
Ontario, CA 91761, United States
Phone: (601) 213-4426
Email: info@benchchem.com

[Contact our Ph.D. Support Team for a compatibility check](#)