

A Comparative Analysis of the Reactivity of Bromic Acid and Other Halogenic Acids

Author: BenchChem Technical Support Team. **Date:** April 2026

Compound of Interest

Compound Name: Bromic acid
CAS No.: 7789-31-3
Cat. No.: B1214919

[Get Quote](#)

For Researchers, Scientists, and Drug Development Professionals

This guide provides a comprehensive comparison of the chemical reactivity of **bromic acid** (HBrO_3) with other key halogenic acids, namely chloric acid (HClO_3) and iodic acid (HIO_3). This objective analysis, supported by experimental data and methodologies, is intended to inform researchers in various fields, including materials science, organic synthesis, and analytical chemistry, where these potent oxidizing agents are frequently employed.

Comparative Reactivity: Key Performance Indicators

The reactivity of halogenic acids can be assessed through several key parameters, including their acid strength (pKa), oxidizing potential (standard reduction potential), and thermal stability. These quantitative metrics provide a clear basis for comparison and are summarized in the tables below.

Acid Strength

The acid strength of the halogenic acids in aqueous solution is a measure of their ability to donate a proton. The pKa value is the negative logarithm of the acid dissociation constant (Ka);

a lower pKa value indicates a stronger acid.

Halogenic Acid	Chemical Formula	pKa
Chloric Acid	HClO ₃	≈ -1.0[1][2]
Bromic Acid	HBrO ₃	≈ -2[3]
Iodic Acid	HIO ₃	≈ 0.77[1][2]

As the data indicates, **bromic acid** is the strongest acid among the three, followed by chloric acid and then iodic acid. This trend is primarily influenced by the electronegativity of the central halogen atom.

Oxidizing Potential

The standard electrode potential (E°) for the reduction of the halate ion to the corresponding halogen provides a direct measure of the oxidizing strength of the halogenic acid in acidic solution. A more positive E° value signifies a stronger oxidizing agent.

Half-Reaction	Standard Reduction Potential (E°)
$2\text{ClO}_3^-(\text{aq}) + 12\text{H}^+(\text{aq}) + 10\text{e}^- \rightarrow \text{Cl}_2(\text{g}) + 6\text{H}_2\text{O}(\text{l})$	+1.47 V[4]
$\text{BrO}_3^-(\text{aq}) + 6\text{H}^+(\text{aq}) + 5\text{e}^- \rightarrow \frac{1}{2}\text{Br}_2(\text{l}) + 3\text{H}_2\text{O}(\text{l})$	+1.5 V[5][6]
$\text{IO}_3^-(\text{aq}) + 6\text{H}^+(\text{aq}) + 5\text{e}^- \rightarrow \frac{1}{2}\text{I}_2(\text{s}) + 3\text{H}_2\text{O}(\text{l})$	+1.195 V[7]

The standard reduction potentials reveal that **bromic acid** is the strongest oxidizing agent in this group, closely followed by chloric acid. Iodic acid is a significantly weaker oxidizing agent in comparison.

Thermal Stability and Decomposition

The thermal stability of the halogenic acids varies significantly. Both chloric and **bromic acids** are known to be unstable and cannot be isolated as pure compounds, existing only in aqueous solutions.[8] Iodic acid, in contrast, is a stable white solid at room temperature.[8][9]

- Chloric Acid (HClO_3): Stable in cold aqueous solutions up to approximately 30% concentration.[10] Above this concentration, it decomposes to form perchloric acid, water, chlorine, and oxygen, or perchloric acid, water, and chlorine dioxide.[10]
- **Bromic Acid** (HBrO_3): Highly unstable, it only exists in aqueous solution.[11] At room temperature, its solutions decompose, turning yellow due to the formation of bromine.[11]
- Iodic Acid (HIO_3): The most stable of the three, existing as a white solid that can be isolated. [8][9]

Experimental Protocols

The quantitative data presented in this guide is derived from established experimental methodologies. The following sections outline the general principles behind the determination of pKa and standard electrode potentials.

Determination of pKa

The pKa of a strong acid is typically determined through a combination of spectroscopic and thermodynamic measurements, as direct titration is not feasible due to the leveling effect of water. Methods such as Raman spectroscopy can be used to quantify the concentration of the undissociated acid in concentrated solutions, from which the acid dissociation constant (K_a) can be calculated.

Determination of Standard Electrode Potential

The standard electrode potential of a half-reaction is measured relative to a Standard Hydrogen Electrode (SHE), which is assigned a potential of exactly 0 V.

Experimental Workflow for Measuring Standard Electrode Potential:

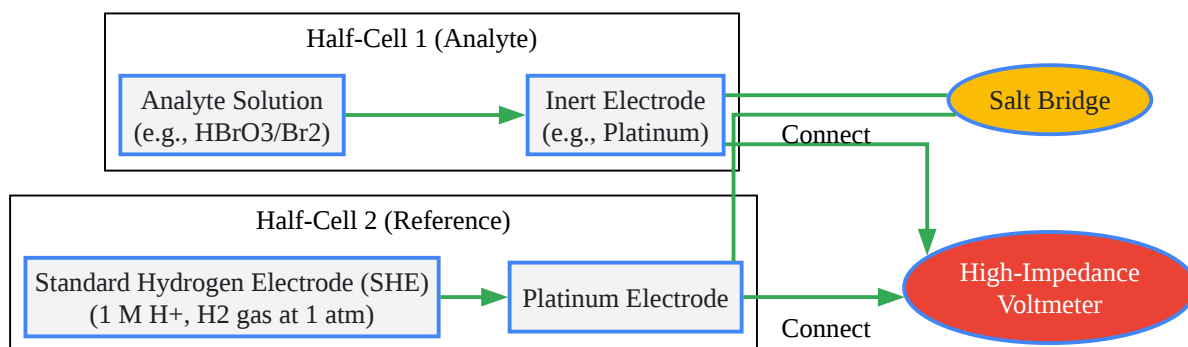

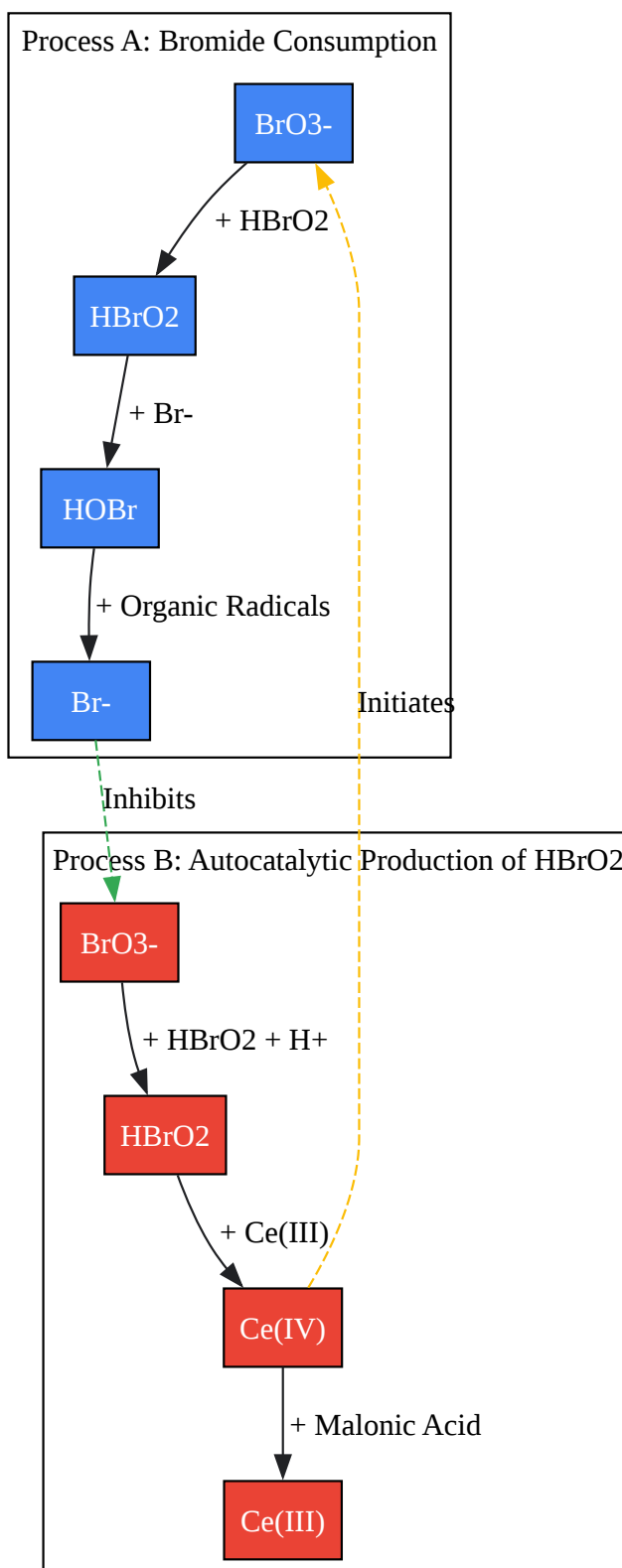

[Click to download full resolution via product page](#)

Need Custom Synthesis?

BenchChem offers custom synthesis for rare earth carbides and specific isotopic labeling.

Email: info@benchchem.com or [Request Quote Online](#).

References

- [1. chem21labs.com](https://chem21labs.com) [chem21labs.com]
- [2. Exploring the mechanism of hypochlorous acid decomposition in aqueous solutions - PubMed](#) [pubmed.ncbi.nlm.nih.gov]
- [3. cdnsiencepub.com](https://cdnsiencepub.com) [cdnsiencepub.com]
- [4. scilearn.sydney.edu.au](https://scilearn.sydney.edu.au) [scilearn.sydney.edu.au]
- [5. chem.libretexts.org](https://chem.libretexts.org) [chem.libretexts.org]
- [6. chem.libretexts.org](https://chem.libretexts.org) [chem.libretexts.org]
- [7. Appendix: Standard Reduction Potentials by Value | Introductory Chemistry](#) [courses.lumenlearning.com]
- [8. Oxoacids of chlorine, bromine and iodine](https://almerja.com) [almerja.com]
- [9. graphsearch.epfl.ch](https://graphsearch.epfl.ch) [graphsearch.epfl.ch]
- [10. Chloric acid - Wikipedia](https://en.wikipedia.org) [en.wikipedia.org]
- [11. Bromic acid - Wikipedia](https://en.wikipedia.org) [en.wikipedia.org]
- To cite this document: BenchChem. [A Comparative Analysis of the Reactivity of Bromic Acid and Other Halogenic Acids]. BenchChem, [2026]. [Online PDF]. Available at: [https://www.benchchem.com/product/b1214919/docs#a-comparative-analysis-of-the-reactivity-of-bromic-acid-and-other-halogenic-acids]

Disclaimer & Data Validity:

The information provided in this document is for Research Use Only (RUO) and is strictly not intended for diagnostic or therapeutic procedures. While BenchChem strives to provide accurate protocols, we make no warranties, express or implied, regarding the fitness of this product for every specific experimental setup.

Technical Support: The protocols provided are for reference purposes. Unsure if this reagent suits your experiment?

Need Industrial/Bulk Grade? [Request Custom Synthesis Quote](#)

BenchChem

Our mission is to be the trusted global source of essential and advanced chemicals, empowering scientists and researchers to drive progress in science and industry.

Contact

Address: 3281 E Guasti Rd
Ontario, CA 91761, United States
Phone: (601) 213-4426
Email: info@benchchem.com

[Contact our Ph.D. Support Team for a compatibility check](#)