

Unveiling Benastatin A: A Comprehensive Technical Overview

Author: BenchChem Technical Support Team. **Date:** April 2026

Compound of Interest

Compound Name:	Benastatin A
CAS No.:	138968-85-1
Cat. No.:	B1213993

[Get Quote](#)

An In-depth Guide for Researchers and Drug Development Professionals

Benastatin A, a polyketide-derived natural product, has garnered significant interest within the scientific community for its diverse biological activities. This technical guide provides a detailed exploration of its core physicochemical properties, serving as a foundational resource for researchers and professionals engaged in drug discovery and development.

Physicochemical Properties of Benastatin A

A thorough understanding of the molecular characteristics of **Benastatin A** is fundamental for its application in experimental settings and as a potential therapeutic agent. The key quantitative data are summarized below.

Property	Value	Source
Molecular Formula	C ₃₀ H ₂₈ O ₇	PubChem[1]
Molecular Weight	500.5 g/mol	PubChem[1]
CAS Number	138968-85-1	ChemicalBook[2]
InChI Key	FUKMCLKFEWEFSC-UHFFFAOYSA-N	ChemDiv[3]
Description	Benastatin A is a potent glutathione S-transferase inhibitor and apoptosis inducer. [2]	ChemicalBook[2]

This structured presentation of data allows for rapid assessment and comparison of the fundamental properties of **Benastatin A**. The compound belongs to the tetracene family and has been isolated from *Streptomyces* species.[1]

Logical Relationship of Benastatin Analogs

The Benastatin family includes several related compounds, each with distinct molecular formulas and weights. The following diagram illustrates the relationship between **Benastatin A** and its common analogs, Benastatin B and Benastatin C, highlighting their distinct molecular compositions.

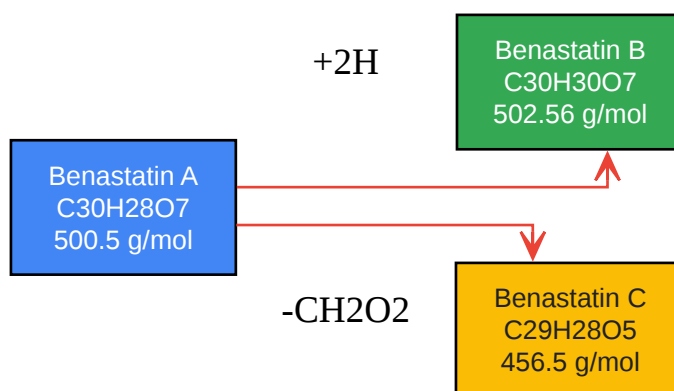

[Click to download full resolution via product page](#)

Molecular formula and weight comparison of **Benastatin** analogs.

This visualization provides a clear and concise comparison of the molecular differences between these closely related natural products, aiding in the selection of appropriate compounds for further investigation. The distinct molecular weights and formulas of Benastatin B[3] and Benastatin C[4] underscore the subtle structural variations that can significantly impact biological activity.

Need Custom Synthesis?

BenchChem offers custom synthesis for rare earth carbides and specific isotopic labeling.

Email: info@benchchem.com or [Request Quote Online](#).

References

- [1. Benastatin A | C30H28O7 | CID 126408 - PubChem \[pubchem.ncbi.nlm.nih.gov\]](#)
- [2. benastatin A | 138968-85-1 \[chemicalbook.com\]](#)
- [3. Compound Benastatin B - Chemdiv \[chemdiv.com\]](#)
- [4. Benastatin C | C29H28O5 | CID 197348 - PubChem \[pubchem.ncbi.nlm.nih.gov\]](#)
- To cite this document: BenchChem. [Unveiling Benastatin A: A Comprehensive Technical Overview]. BenchChem, [2026]. [Online PDF]. Available at: [\[https://www.benchchem.com/product/b1213993/docs#unveiling-benastatin-a-a-comprehensive-technical-overview\]](https://www.benchchem.com/product/b1213993/docs#unveiling-benastatin-a-a-comprehensive-technical-overview)

Disclaimer & Data Validity:

The information provided in this document is for Research Use Only (RUO) and is strictly not intended for diagnostic or therapeutic procedures. While BenchChem strives to provide accurate protocols, we make no warranties, express or implied, regarding the fitness of this product for every specific experimental setup.

Technical Support: The protocols provided are for reference purposes. Unsure if this reagent suits your experiment?

Need Industrial/Bulk Grade? [Request Custom Synthesis Quote](#)

BenchChem

Our mission is to be the trusted global source of essential and advanced chemicals, empowering scientists and researchers to drive progress in science and industry.

Contact

Address: 3281 E Guasti Rd

Ontario, CA 91761, United States

Phone: (601) 213-4426

Email: info@benchchem.com

[Contact our Ph.D. Support Team for a compatibility check](#)