

Lauryl Palmitate: A Bio-Based Phase Change Material for Advanced Thermal Applications

Author: BenchChem Technical Support Team. **Date:** April 2026

Compound of Interest

Compound Name: *Lauryl Palmitate*

CAS No.: 42232-29-1

Cat. No.: B1213196

[Get Quote](#)

An In-depth Technical Guide for Researchers, Scientists, and Drug Development Professionals

Introduction: **Lauryl Palmitate**, a wax ester formed from the esterification of lauric acid and palmitic acid, is emerging as a promising bio-based phase change material (PCM). Derived from renewable vegetable sources, it offers an environmentally friendly alternative to petroleum-based PCMs. Its favorable thermal properties, including a distinct melting point and latent heat storage capacity, make it a candidate for a variety of applications ranging from thermal energy storage in buildings to potential uses in sophisticated drug delivery systems. This technical guide provides a comprehensive overview of the synthesis, thermophysical properties, and experimental characterization of **Lauryl Palmitate**, with a forward-looking perspective on its application in the pharmaceutical sciences.

Thermophysical Properties of Lauryl Palmitate

Lauryl Palmitate, also known as dodecyl hexadecanoate, possesses thermal characteristics that are crucial for its function as a phase change material. The key properties are summarized in the table below. It is important to note that while the melting point is experimentally well-documented, experimental data for latent heat of fusion and thermal conductivity are not readily

available in the literature. The values presented here are based on predictive models and data from similar wax esters.

Property	Value	Unit	Source/Method
Melting Point	44 - 45	°C	Experimental Data
	50 - 55	°C	Experimental Data[1]
Latent Heat of Fusion	71.06	kJ/mol	Joback Method (Calculated)[2]
	~167	J/g	Calculated from Joback Method value
Thermal Conductivity	Not Experimentally Determined	W/(m·K)	-
Molecular Formula	C ₂₈ H ₅₆ O ₂	-	-
Molecular Weight	424.74	g/mol	-

Note: The calculated latent heat of fusion is an estimation and should be confirmed by experimental analysis for critical applications.

Synthesis of Lauryl Palmitate

Lauryl Palmitate is synthesized through the esterification of palmitic acid with lauryl alcohol. A green synthesis approach utilizing an immobilized lipase catalyst is a preferred method due to its mild reaction conditions and high specificity.

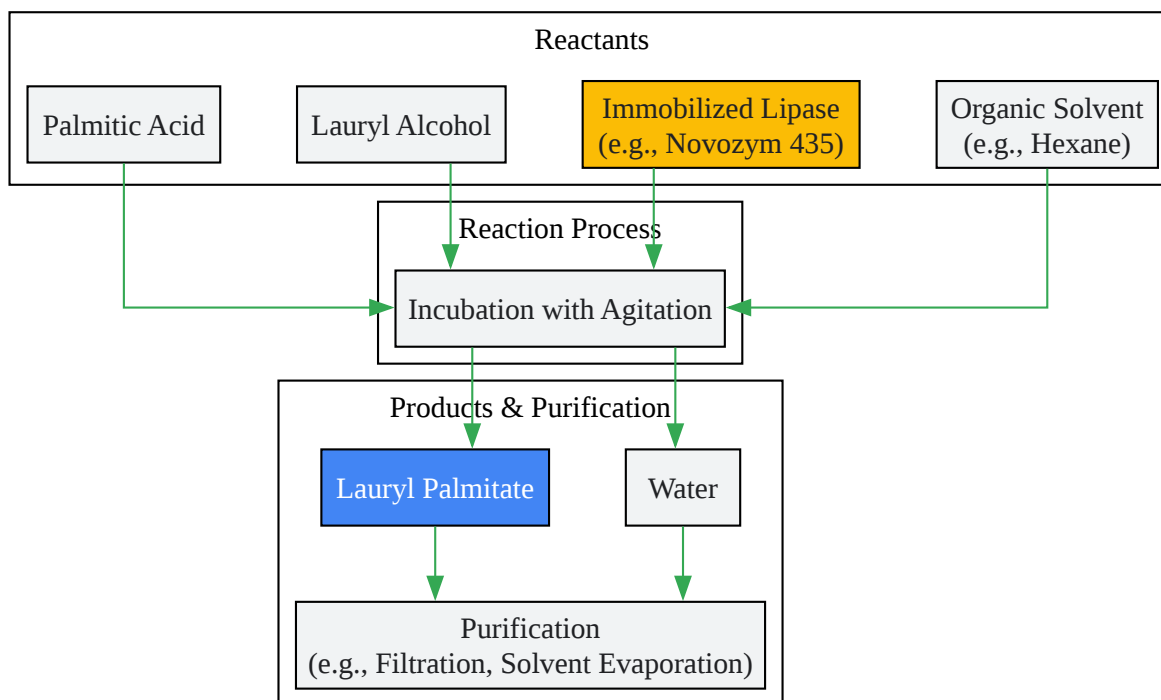

[Click to download full resolution via product page](#)

Fig. 1: Lipase-catalyzed synthesis of **Lauryl Palmitate**.

Experimental Protocol: Lipase-Catalyzed Esterification[3][4][5]

This protocol outlines a general laboratory procedure for the green synthesis of **Lauryl Palmitate**.

- **Reactant Preparation:** In a reaction vessel, combine palmitic acid and lauryl alcohol in a 1:2 molar ratio.
- **Solvent and Catalyst Addition:** Add a suitable organic solvent, such as hexane, to the mixture. Introduce an immobilized lipase, for example, Novozym 435, as the biocatalyst.

- **Reaction Conditions:** Incubate the mixture at a controlled temperature, typically around 40°C, with constant agitation (e.g., 150 rpm) for a specified reaction time (e.g., 10 minutes for optimal conversion).
- **Reaction Termination:** Stop the reaction by adding a mixture of ethanol and acetone (1:1 v/v).
- **Product Identification and Analysis:**
 - **Thin Layer Chromatography (TLC):** Monitor the progress of the reaction and identify the product. A developing solvent system of hexane and anhydrous ether (7:3, v/v) can be used.
 - **Fourier-Transform Infrared Spectroscopy (FTIR):** Confirm the formation of the ester bond.
 - **Gas Chromatography (GC):** Determine the purity of the synthesized **Lauryl Palmitate**.
 - **Titration:** The percentage conversion can be determined by titrating the remaining unreacted fatty acids with a standardized solution of sodium hydroxide.
- **Purification:** The immobilized enzyme can be recovered by filtration for reuse. The solvent is then removed under reduced pressure to yield the crude **Lauryl Palmitate**, which can be further purified if necessary.

Characterization of Thermophysical Properties

The characterization of **Lauryl Palmitate** as a PCM involves determining its key thermal properties. The following workflow outlines the typical experimental procedures.

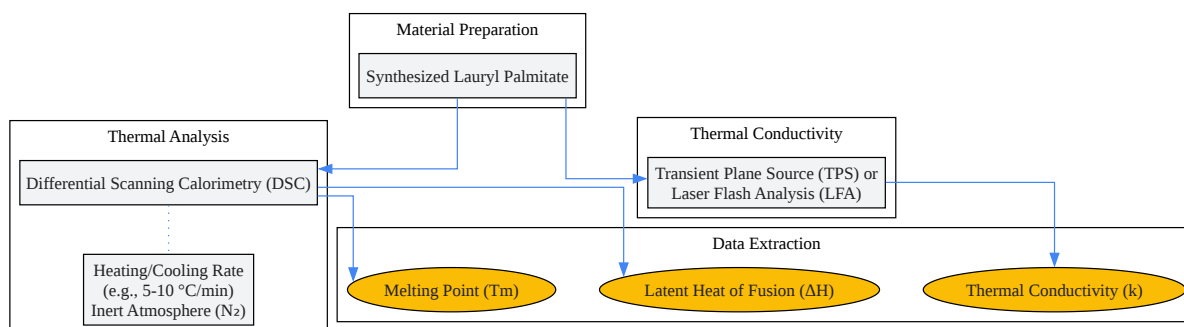

[Click to download full resolution via product page](#)

Need Custom Synthesis?

BenchChem offers custom synthesis for rare earth carbides and specific isotopic labeling.

Email: info@benchchem.com or [Request Quote Online](#).

References

- 1. LAURYL PALMITATE [chembk.com]
- 2. Wax esters | Cyberlipid [cyberlipid.gerli.com]
- To cite this document: BenchChem. [Lauryl Palmitate: A Bio-Based Phase Change Material for Advanced Thermal Applications]. BenchChem, [2026]. [Online PDF]. Available at: [<https://www.benchchem.com/product/b1213196/docs#lauryl-palmitate-a-bio-based-phase-change-material-for-advanced-thermal-applications>]

Disclaimer & Data Validity:

The information provided in this document is for Research Use Only (RUO) and is strictly not intended for diagnostic or therapeutic procedures. While BenchChem strives to provide accurate protocols, we make no warranties, express or implied, regarding the fitness of this product for every specific experimental setup.

Technical Support: The protocols provided are for reference purposes. Unsure if this reagent suits your experiment?

Need Industrial/Bulk Grade? [Request Custom Synthesis Quote](#)

BenchChem

Our mission is to be the trusted global source of essential and advanced chemicals, empowering scientists and researchers to drive progress in science and industry.

Contact

Address: 3281 E Guasti Rd
Ontario, CA 91761, United States
Phone: (601) 213-4426
Email: info@benchchem.com

[Contact our Ph.D. Support Team for a compatibility check](#)