

# An In-Depth Technical Guide to the Spectroscopic Analysis of Lauryl Palmitate

**Author:** BenchChem Technical Support Team. **Date:** April 2026

## Compound of Interest

Compound Name: *Lauryl Palmitate*

CAS No.: 42232-29-1

Cat. No.: B1213196

[Get Quote](#)

For Researchers, Scientists, and Drug Development Professionals

This technical guide provides a comprehensive overview of the spectroscopic data for **Lauryl Palmitate** (dodecyl hexadecanoate), a wax ester commonly used in cosmetics, personal care products, and as a metabolite in biological systems. This document details expected Nuclear Magnetic Resonance (NMR), Fourier-Transform Infrared (FTIR) spectroscopy, and Mass Spectrometry (MS) data, along with detailed experimental protocols for acquiring such data.

## Chemical Structure and Properties

**Lauryl Palmitate** is the ester formed from the condensation of lauryl alcohol (1-dodecanol) and palmitic acid (hexadecanoic acid). Its chemical structure and properties are fundamental to interpreting its spectroscopic data.

- Chemical Formula:  $C_{28}H_{56}O_2$
- Molecular Weight: 424.74 g/mol [1]
- IUPAC Name: Dodecyl hexadecanoate[2][3]

- CAS Number: 42232-29-1[1]

## Spectroscopic Data

The following sections present the expected spectroscopic data for **Lauryl Palmitate**. While direct experimental spectra can be found in databases such as SpectraBase for FTIR and  $^{13}\text{C}$  NMR, and the NIST Mass Spectrometry Data Center for mass spectra, this guide provides an interpreted summary of the expected data based on known chemical principles and data from similar long-chain esters.[2]

## Nuclear Magnetic Resonance (NMR) Spectroscopy

NMR spectroscopy is a powerful tool for elucidating the carbon-hydrogen framework of a molecule. For **Lauryl Palmitate**, both  $^1\text{H}$  and  $^{13}\text{C}$  NMR provide distinct signals corresponding to the different chemical environments of the nuclei in the fatty acid and alcohol chains.

Table 1: Predicted  $^1\text{H}$  NMR Spectroscopic Data for **Lauryl Palmitate** (in  $\text{CDCl}_3$ )

Chemical Shift ( $\delta$ ) ppm	Multiplicity	Integration	Assignment
~4.05	Triplet	2H	-O-CH <sub>2</sub> - (a)
~2.28	Triplet	2H	-CH <sub>2</sub> -C=O (b)
~1.62	Multiplet	4H	-O-CH <sub>2</sub> -CH <sub>2</sub> - (c), - CH <sub>2</sub> -CH <sub>2</sub> -C=O (d)
~1.25	Broad Singlet	42H	-(CH <sub>2</sub> ) <sub>n</sub> - (e, f)
~0.88	Triplet	6H	-CH <sub>3</sub> (g, h)

Table 2: Predicted  $^{13}\text{C}$  NMR Spectroscopic Data for **Lauryl Palmitate** (in  $\text{CDCl}_3$ )

Chemical Shift ( $\delta$ ) ppm	Assignment
~173.9	C=O (Ester carbonyl)
~64.4	-O-CH <sub>2</sub> -
~34.4	-CH <sub>2</sub> -C=O
~31.9	Methylene carbons in the backbone
~29.7	Methylene carbons in the backbone
~29.5	Methylene carbons in the backbone
~29.3	Methylene carbons in the backbone
~29.1	Methylene carbons in the backbone
~28.7	Methylene carbons in the backbone
~25.9	Methylene carbons in the backbone
~25.1	Methylene carbons in the backbone
~22.7	Methylene carbons near the methyl end
~14.1	-CH <sub>3</sub>

## Fourier-Transform Infrared (FTIR) Spectroscopy

FTIR spectroscopy is used to identify the functional groups present in a molecule. The spectrum of **Lauryl Palmitate** is characterized by strong absorptions corresponding to the ester group and the long hydrocarbon chains.

Table 3: Key FTIR Absorption Bands for **Lauryl Palmitate**

Wavenumber (cm <sup>-1</sup> )	Intensity	Vibration	Functional Group
~2918	Strong	C-H Asymmetric Stretch	Alkane (-CH <sub>2</sub> )
~2850	Strong	C-H Symmetric Stretch	Alkane (-CH <sub>2</sub> )
~1738	Strong	C=O Stretch	Ester
~1465	Medium	C-H Bend (Scissoring)	Alkane (-CH <sub>2</sub> )
~1170	Strong	C-O Stretch	Ester
~722	Medium	C-H Bend (Rocking)	Alkane (-(CH <sub>2</sub> ) <sub>n</sub> -, n≥4)

## Mass Spectrometry (MS)

Mass spectrometry provides information about the molecular weight and fragmentation pattern of a molecule. For **Lauryl Palmitate**, Electron Ionization (EI) would likely lead to fragmentation of the long alkyl chains and cleavage around the ester group.

Table 4: Expected Key Fragments in the Mass Spectrum of **Lauryl Palmitate**

m/z	Interpretation
424	[M] <sup>+</sup> (Molecular Ion)
257	[CH <sub>3</sub> (CH <sub>2</sub> ) <sub>14</sub> CO] <sup>+</sup> (Acylium ion from palmitic acid)
168	[CH <sub>3</sub> (CH <sub>2</sub> ) <sub>10</sub> CH <sub>2</sub> ] <sup>+</sup> (Lauryl carbocation)
Series of peaks differing by 14	Loss of -CH <sub>2</sub> - units from the alkyl chains

## Experimental Protocols

The following are detailed methodologies for acquiring the spectroscopic data for **Lauryl Palmitate**.

## NMR Spectroscopy

### Sample Preparation:

- Accurately weigh approximately 10-20 mg of **Lauryl Palmitate** into a clean, dry NMR tube.
- Add approximately 0.6-0.7 mL of deuterated chloroform ( $\text{CDCl}_3$ ) to the NMR tube to dissolve the sample.
- Add a small amount of an internal standard, such as tetramethylsilane (TMS), for chemical shift referencing ( $\delta$  0.00 ppm).
- Cap the NMR tube and gently invert to ensure the sample is fully dissolved and the solution is homogeneous.

### $^1\text{H}$ NMR Acquisition:

- Spectrometer: 400 MHz or higher field NMR spectrometer.
- Pulse Sequence: Standard single-pulse sequence.
- Acquisition Time: 2-4 seconds.
- Relaxation Delay: 1-2 seconds.
- Number of Scans: 8-16, depending on the desired signal-to-noise ratio.
- Spectral Width: 0-12 ppm.

### $^{13}\text{C}$ NMR Acquisition:

- Spectrometer: 100 MHz or higher field NMR spectrometer.
- Pulse Sequence: Proton-decoupled single-pulse sequence.
- Acquisition Time: 1-2 seconds.
- Relaxation Delay: 2-5 seconds.

- Number of Scans: 1024 or more to achieve an adequate signal-to-noise ratio due to the low natural abundance of  $^{13}\text{C}$ .
- Spectral Width: 0-200 ppm.

## FTIR Spectroscopy

Sample Preparation (Attenuated Total Reflectance - ATR):

- Ensure the ATR crystal is clean by wiping it with a solvent such as isopropanol and allowing it to dry completely.
- Record a background spectrum of the clean, empty ATR crystal.
- Place a small amount of solid **Lauryl Palmitate** onto the center of the ATR crystal.
- Lower the ATR press and apply consistent pressure to ensure good contact between the sample and the crystal.
- Collect the sample spectrum.

Data Acquisition:

- Spectrometer: A standard FTIR spectrometer equipped with a diamond or germanium ATR accessory.
- Spectral Range: 4000-400  $\text{cm}^{-1}$ .
- Resolution: 4  $\text{cm}^{-1}$ .
- Number of Scans: 16-32 scans are typically co-added to improve the signal-to-noise ratio.

## Mass Spectrometry (Gas Chromatography-Mass Spectrometry - GC-MS)

Sample Preparation:

- Prepare a stock solution of **Lauryl Palmitate** in a volatile organic solvent such as hexane or dichloromethane at a concentration of approximately 1 mg/mL.
- Perform serial dilutions to obtain a final concentration suitable for GC-MS analysis (e.g., 1-10 µg/mL).

#### GC-MS System and Conditions:

- Gas Chromatograph: A standard GC system equipped with a capillary column suitable for the analysis of fatty acid esters (e.g., a non-polar or medium-polarity column like a DB-5ms or HP-5ms).
- Injection: 1 µL of the sample solution is injected in splitless mode.
- Injector Temperature: 250-280 °C.
- Oven Temperature Program:
  - Initial temperature: 100 °C, hold for 1 minute.
  - Ramp: Increase to 300 °C at a rate of 10-15 °C/minute.
  - Final hold: Hold at 300 °C for 5-10 minutes.
- Carrier Gas: Helium at a constant flow rate of approximately 1 mL/min.
- Mass Spectrometer: A quadrupole or ion trap mass spectrometer.
- Ionization Mode: Electron Ionization (EI) at 70 eV.
- Mass Range: Scan from m/z 40 to 500.
- Ion Source Temperature: 230 °C.
- Quadrupole Temperature: 150 °C.

## Workflow and Relationships

The following diagrams illustrate the logical workflow for the spectroscopic analysis of a fatty acid ester like **Lauryl Palmitate** and the relationship between the different spectroscopic techniques and the structural information they provide.

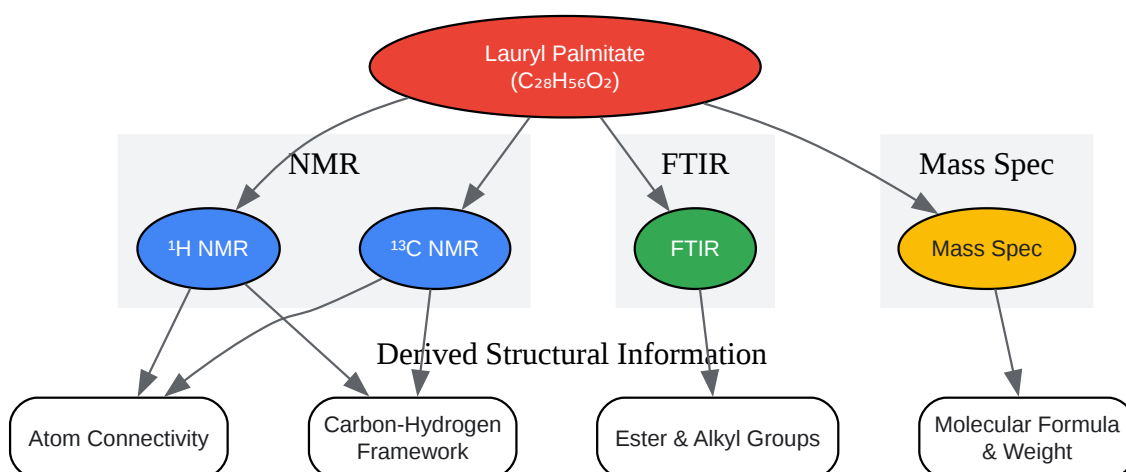
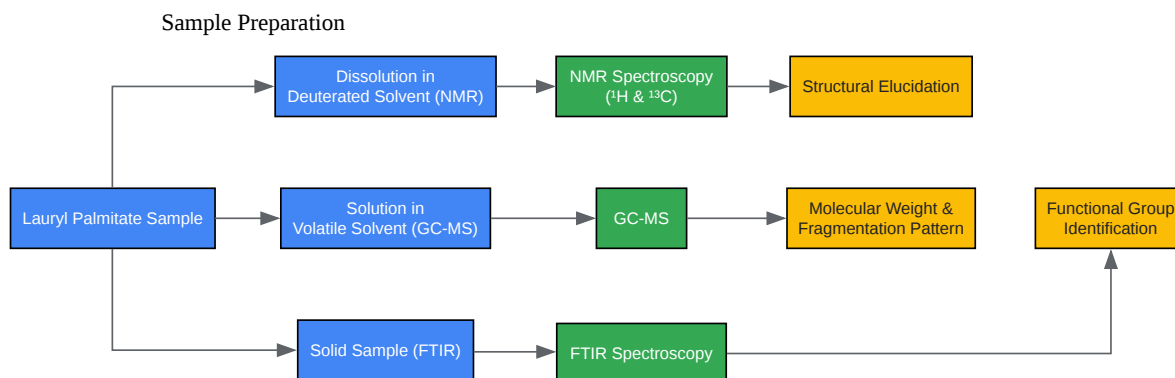

[Click to download full resolution via product page](#)

### Need Custom Synthesis?

BenchChem offers custom synthesis for rare earth carbides and specific isotopic labeling.

Email: [info@benchchem.com](mailto:info@benchchem.com) or [Request Quote Online](#).

## References

- [1. larodan.com \[larodan.com\]](http://larodan.com)
- [2. journals.tubitak.gov.tr \[journals.tubitak.gov.tr\]](http://journals.tubitak.gov.tr)
- [3. Lauryl Palmitate | C28H56O2 | CID 110202 - PubChem \[pubchem.ncbi.nlm.nih.gov\]](https://pubchem.ncbi.nlm.nih.gov)
- To cite this document: BenchChem. [An In-Depth Technical Guide to the Spectroscopic Analysis of Lauryl Palmitate]. BenchChem, [2026]. [Online PDF]. Available at: [\[https://www.benchchem.com/product/b1213196/docs#an-in-depth-technical-guide-to-the-spectroscopic-analysis-of-lauryl-palmitate\]](https://www.benchchem.com/product/b1213196/docs#an-in-depth-technical-guide-to-the-spectroscopic-analysis-of-lauryl-palmitate)

### Disclaimer & Data Validity:

The information provided in this document is for Research Use Only (RUO) and is strictly not intended for diagnostic or therapeutic procedures. While BenchChem strives to provide accurate protocols, we make no warranties, express or implied, regarding the fitness of this product for every specific experimental setup.

**Technical Support:** The protocols provided are for reference purposes. Unsure if this reagent suits your experiment?

**Need Industrial/Bulk Grade?** [Request Custom Synthesis Quote](#)

## BenchChem

Our mission is to be the trusted global source of essential and advanced chemicals, empowering scientists and researchers to drive progress in science and industry.

### Contact

Address: 3281 E Guasti Rd  
Ontario, CA 91761, United States  
Phone: (601) 213-4426  
Email: [info@benchchem.com](mailto:info@benchchem.com)

Contact our Ph.D. Support Team for a compatibility check