

Technical Support Center: Reaction Monitoring of 2-(butylthio)ethanamine

Author: BenchChem Technical Support Team. **Date:** April 2026

Compound of Interest

Compound Name: *Ethanamine, 2-(butylthio)-*

CAS No.: 3581-01-9

Cat. No.: B12124140

[Get Quote](#)

Welcome to the Analytical Technical Support Center. This guide is specifically engineered for researchers and drug development professionals tasked with monitoring reactions involving 2-(butylthio)ethanamine (CAS: 3581-01-9).

Due to its specific structural features—a highly polar primary aliphatic amine coupled with an oxidizable thioether linkage—this compound presents unique challenges in both Thin Layer Chromatography (TLC) and High-Performance Liquid Chromatography (HPLC). This guide synthesizes field-proven troubleshooting strategies, mechanistic causality, and self-validating protocols to ensure robust analytical tracking.

PART 1: TLC Troubleshooting & Visualization Strategies

Frequently Asked Questions (FAQs)

Q1: Why is my 2-(butylthio)ethanamine spot completely invisible under 254 nm UV light?

Causality: 2-(butylthio)ethanamine lacks a conjugated

-electron system or aromatic ring. The thioether and aliphatic amine moieties do not absorb UV light at 254 nm. Solution: You must use a destructive chemical stain. The Ninhydrin test is the gold standard for primary amines. Ninhydrin acts as an oxidizing agent, triggering the oxidative deamination and decarboxylation of the primary amine. The released ammonia condenses with a second ninhydrin molecule to form a deep blue/purple complex known as Ruhemann's Purple

Q2: My amine spot streaks continuously from the baseline to the solvent front. How do I achieve a tight, symmetrical spot? Causality: Unmodified silica gel contains surface silanol groups (

) with a

of ~4.5–5.0. The primary amine of 2-(butylthio)ethanamine (

~10.5) becomes protonated and binds ionically to these negatively charged silanols, causing severe retention and streaking. Solution: Modify your mobile phase by adding 1–5% of a volatile base, such as Triethylamine (TEA) or concentrated Ammonium Hydroxide (

). The base competitively saturates the acidic silanol sites on the silica plate, allowing your analyte to migrate freely based on its inherent polarity.

Mechanistic Pathway: Ninhydrin Visualization

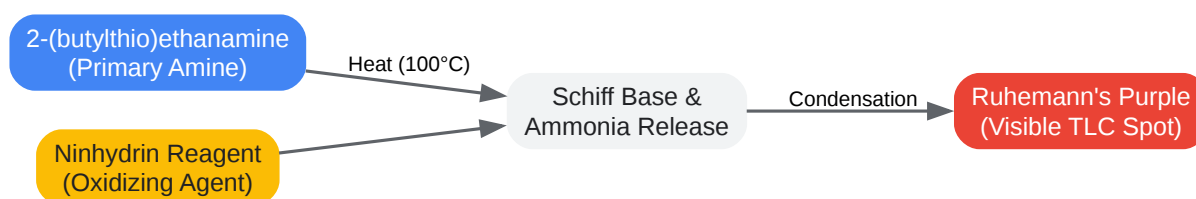

[Click to download full resolution via product page](#)

Reaction pathway of 2-(butylthio)ethanamine with Ninhydrin to form Ruhemann's Purple.

Self-Validating Protocol: TLC Reaction Monitoring

- Mobile Phase Preparation: Prepare a highly polar, basic solvent system (e.g., Dichloromethane : Methanol :

in a 90:9:1 ratio).

- Stain Preparation: Dissolve 0.2 g of Ninhydrin in 10 mL of ethanol (2% w/v solution) .
- Spotting & Elution: Apply 1–2

L of the reaction mixture alongside a pure standard of 2-(butylthio)ethanamine. Elute the plate in a saturated chamber.

- Visualization: Allow the plate to dry completely to remove residual (which can cause background staining). Dip the plate in the Ninhydrin solution and heat at 110°C using a heat gun for 2–3 minutes until distinct purple spots appear.
- Self-Validation Step: Always co-spot the starting material over the reaction mixture spot (cross-spotting). If the mixed spot resolves into a figure-eight or two distinct spots, the difference is chemically genuine and not a concentration-induced artifact.

PART 2: HPLC Method Development & Peak Shape Optimization

Frequently Asked Questions (FAQs)

Q3: Standard UV detection at 254 nm shows nothing, and 210 nm is too noisy. What is the best HPLC detector for this compound? Causality: The thioether linkage provides only weak end-absorption (

< 215 nm). At this low wavelength, mobile phase solvents (especially gradients using TFA or methanol) absorb heavily, causing severe baseline drift and poor signal-to-noise ratios.

Solution: Switch to a universal detector that relies on analyte mass rather than optical properties. A Charged Aerosol Detector (CAD) or Evaporative Light Scattering Detector (ELSD) is ideal for non-volatile aliphatic amines. Alternatively, use LC-MS with Electrospray Ionization in positive mode (ESI+), which is highly sensitive to basic amines.

Q4: I am observing severe peak tailing (Asymmetry Factor > 2.0) on my C18 column. How do I fix this? Causality: Peak tailing for aliphatic amines is primarily driven by secondary interactions. While the hydrophobic butyl chain interacts with the C18 phase, the protonated primary amine interacts ionically with ionized residual silanols (

) on the silica support . Solution: You must suppress silanol ionization. Lower the mobile phase pH to ~2.5 using 0.1% Trifluoroacetic acid (TFA). At pH 2.5, the silanols are fully protonated and neutral (

), eliminating the ionic interaction . Furthermore, utilizing an end-capped, Type B high-purity silica column will sterically block remaining active sites.

Q5: My LC-MS data shows unexpected peaks at +16 Da and +32 Da relative to the target mass. What is happening? Causality: The thioether moiety is highly susceptible to spontaneous oxidation in aqueous environments, especially if peroxide impurities are present in older ether/THF solvents used during sample prep. The +16 Da peak corresponds to the sulfoxide derivative, and the +32 Da peak corresponds to the sulfone derivative. Solution: Purge your mobile phases with inert gas (Helium or Nitrogen) and ensure sample vials are prepared fresh and stored away from light and atmospheric oxygen.

Quantitative Data: Impact of HPLC Conditions on Peak Symmetry

HPLC Condition	Mobile Phase pH	Column Type	USP Tailing Factor ()	Analytical Outcome
Standard RP-HPLC	7.0 (Water/MeCN)	Standard C18 (Type A)	> 2.5 (Severe)	Poor integration, overlapping impurities.
Acidic RP-HPLC	2.5 (0.1% TFA)	Standard C18 (Type A)	1.4 - 1.6 (Moderate)	Improved, but secondary interactions persist.
Optimized RP-HPLC	2.5 (0.1% TFA)	End-capped C18 (Type B)	1.0 - 1.1 (Excellent)	Sharp, symmetrical peaks, accurate quantitation.
Ion-Pairing HPLC	6.5 (10 mM HFBA)	End-capped C18	1.1 - 1.2 (Good)	Good symmetry, but incompatible with LC-MS.

Decision Workflow: HPLC Troubleshooting

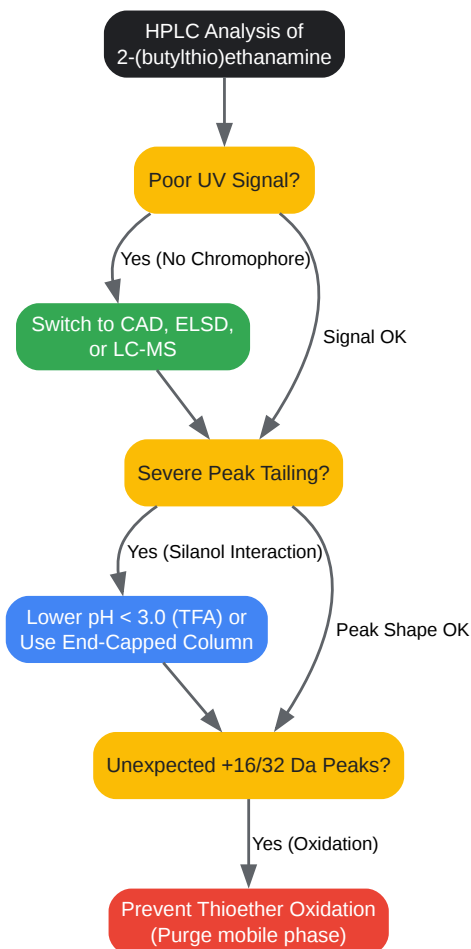

[Click to download full resolution via product page](#)

Decision tree for troubleshooting HPLC analysis of 2-(butylthio)ethanamine.

Self-Validating Protocol: LC-CAD Method for Aliphatic Amines

- Column Selection: Install a fully end-capped, Type B silica C18 column (e.g., Waters XBridge or Agilent ZORBAX Eclipse Plus, 150 x 4.6 mm, 3.5 μ m).
- Mobile Phase Preparation:
 - Solvent A: Ultrapure Water with 0.1% v/v TFA.
 - Solvent B: HPLC-grade Acetonitrile with 0.1% v/v TFA.

- Gradient Elution: Run a linear gradient from 5% B to 95% B over 15 minutes at a flow rate of 1.0 mL/min.
- Detector Settings (CAD): Set the evaporation temperature to 35°C. Ensure the nitrogen gas pressure is stable at the manufacturer's recommended psi.
- Self-Validation Step: Before injecting the amine, inject a system suitability mixture containing Uracil (to determine the column void volume,

) and Toluene (a neutral hydrophobic marker).
 - Diagnostic Check: If Toluene exhibits peak tailing, the column frit is physically blocked or the bed is collapsed. If Toluene is perfectly symmetrical but 2-(butylthio)ethanamine tails, the issue is strictly chemical (silanol interaction), confirming the need for fresh mobile phase buffer or a newer end-capped column.

References

- Vedantu. "Ninhydrin Test: Principle, Reaction & Application." Vedantu Chemistry Resources. Available at:[\[Link\]](#)
- Element Lab Solutions. "Peak Tailing in HPLC." Element Lab Solutions Technical Articles. Available at: [\[Link\]](#)
- Chromatography Online. "HPLC Diagnostic Skills II – Tailing Peaks." The LCGC Blog. Available at: [\[Link\]](#)
- To cite this document: BenchChem. [Technical Support Center: Reaction Monitoring of 2-(butylthio)ethanamine]. BenchChem, [2026]. [Online PDF]. Available at: [\[https://www.benchchem.com/product/b12124140/docs#technical-support-center-reaction-monitoring-of-2-butylthio-ethanamine\]](https://www.benchchem.com/product/b12124140/docs#technical-support-center-reaction-monitoring-of-2-butylthio-ethanamine)

Disclaimer & Data Validity:

The information provided in this document is for Research Use Only (RUO) and is strictly not intended for diagnostic or therapeutic procedures. While BenchChem strives to provide

accurate protocols, we make no warranties, express or implied, regarding the fitness of this product for every specific experimental setup.

Technical Support: The protocols provided are for reference purposes. Unsure if this reagent suits your experiment?

Need Industrial/Bulk Grade? [Request Custom Synthesis Quote](#)

BenchChem

Our mission is to be the trusted global source of essential and advanced chemicals, empowering scientists and researchers to drive progress in science and industry.

Contact

Address: 3281 E Guasti Rd

Ontario, CA 91761, United States

Phone: (601) 213-4426

Email: info@benchchem.com

[Contact our Ph.D. Support Team for a compatibility check](#)