

A Technical Guide to the Charge Transport Mechanism in Poly(diphenylbenzidine)

Author: BenchChem Technical Support Team. **Date:** May 2026

Compound of Interest

Compound Name: Poly(diphenylbenzidine)

Cat. No.: B12113712

[Get Quote](#)

For Researchers, Scientists, and Drug Development Professionals

Introduction: The Promise of Poly(diphenylbenzidine) in Organic Electronics

Poly(diphenylbenzidine) (PDPB) and its derivatives represent a significant class of semiconducting polymers, primarily utilized for their exceptional hole-transporting properties.^[1] These materials are integral to the advancement of various organic electronic devices, including Organic Light-Emitting Diodes (OLEDs), organic photovoltaics (OPVs), and quantum-dot-based light-emitting diodes (QLEDs).^[1] The core functionality of PDPB in these applications lies in its ability to efficiently transport positive charge carriers (holes), a critical process for device performance and efficiency. This guide provides an in-depth exploration of the fundamental charge transport mechanism in PDPB, detailing the theoretical underpinnings, experimental characterization techniques, and key factors that influence its conductivity.

Synthesis and Chemical Structure: The Foundation of Electronic Properties

The electronic characteristics of PDPB are intrinsically linked to its molecular structure, which is established during its synthesis. While various synthetic routes exist for producing conducting polymers, Yamamoto polycondensation is a common and effective method for creating polymers like poly(tetraphenylbenzidines), which share a similar backbone to PDPB.[2] This process involves the coupling of dihalogenated monomers in the presence of a nickel catalyst. The diamine structure of N,N'-diphenylbenzidine and its derivatives makes them suitable monomers for such polymerization reactions, leading to the formation of high-molecular-weight polymers with desirable thermal stability and electronic properties.[3]

The general scheme for the synthesis of a **poly(diphenylbenzidine)** derivative via Yamamoto polycondensation can be visualized as follows:

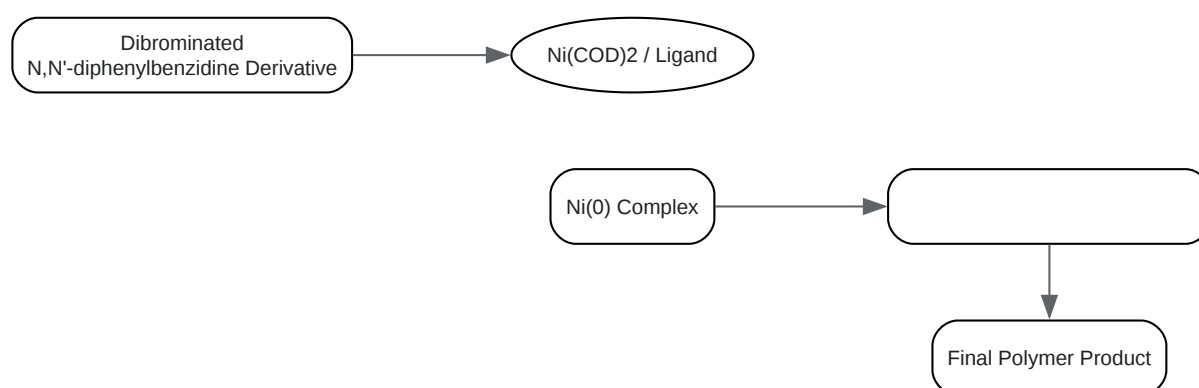

[Click to download full resolution via product page](#)

Caption: Generalized Yamamoto Polycondensation for PDPB Synthesis.

The resulting polymer consists of repeating diphenylbenzidine units, which form a π -conjugated backbone. This extended conjugation is crucial for the delocalization of electrons and the subsequent movement of charge carriers along the polymer chain.

Theoretical Framework: Understanding Charge Transport in Disordered Organic Semiconductors

Unlike crystalline inorganic semiconductors, which are characterized by well-defined energy bands, conducting polymers like PDPB are typically amorphous or semi-crystalline. This

structural disorder has a profound impact on the mechanism of charge transport. Instead of charge carriers moving freely within energy bands, they are localized on specific molecular sites and move through a process known as hopping transport.[4]

Several theoretical models describe hopping transport in disordered organic semiconductors, with the Gaussian Disorder Model (GDM) and Marcus Theory being particularly relevant.[3][4][5]

- Gaussian Disorder Model (GDM): This model posits that the energies of the localized states (the Highest Occupied Molecular Orbital or HOMO for holes) are not uniform but follow a Gaussian distribution due to the structural disorder. Charge carriers hop between these sites, with the hopping rate being dependent on the energetic difference between the initial and final sites and the spatial distance between them.[3]
- Marcus Theory: This theory describes the rate of electron transfer between two molecules (or molecular sites). It considers the reorganization energy (the energy required to distort the molecular geometry upon charge transfer) and the free energy difference between the initial and final states.[4]

In essence, charge transport in PDPB is a thermally activated process where holes "hop" from one diphenylbenzidine unit to the next, overcoming an energy barrier. The efficiency of this process is determined by the degree of energetic and positional disorder within the polymer film.

The Dominant Charge Transport Mechanism in Poly(diphenylbenzidine)

Based on experimental evidence, the dominant charge transport mechanism in **poly(diphenylbenzidine)** is hopping of holes between localized states.[1] This is characteristic of a p-type semiconductor, where the majority charge carriers are positive. The process can be visualized as a series of discrete jumps of a positive charge from one neutral polymer segment to an adjacent one, effectively creating a mobile "hole".

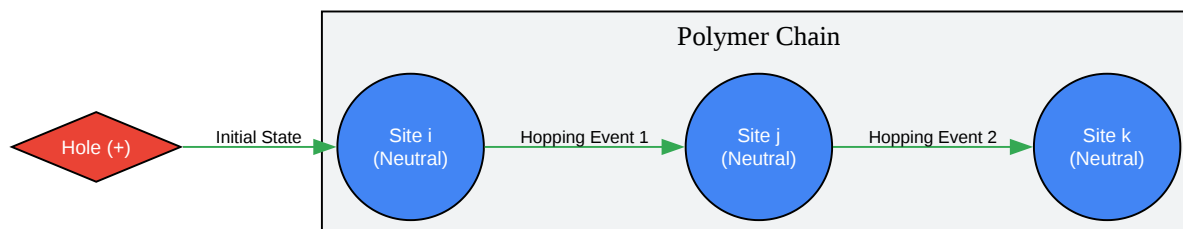

[Click to download full resolution via product page](#)

Caption: Conceptual Diagram of Hole Hopping in PDPB.

The efficiency of this hopping transport is quantified by the hole mobility (μ_h), a measure of how quickly a hole can move through the material under the influence of an electric field. Higher mobility values are desirable for most electronic applications as they lead to lower device resistance and improved performance.

Experimental Characterization of Charge Transport

Several experimental techniques are employed to measure the charge carrier mobility in organic semiconductors. For PDPB, the most common methods are Time-of-Flight (TOF) and Space-Charge-Limited Current (SCLC) measurements.

Time-of-Flight (TOF) Measurements

The TOF technique directly measures the time it takes for a sheet of photogenerated charge carriers to traverse a known thickness of the material under an applied electric field.[6]

- Device Fabrication:
 - A sandwich-type device is fabricated with the PDPB film between two electrodes.[7]
 - One electrode must be transparent (e.g., Indium Tin Oxide - ITO) to allow for photoexcitation.[7]
 - Crucially, at least one of the electrodes should be a blocking contact to prevent charge injection from the electrode, which would interfere with the measurement of the

photogenerated carriers.[8] An insulating layer, such as aluminum oxide on an aluminum electrode, can serve as a blocking contact.[8]

- Measurement Setup:
 - The device is placed in a cryostat to allow for temperature-dependent measurements.[7]
 - A pulsed laser with a photon energy sufficient to generate electron-hole pairs in the PDPB is used for excitation.[7]
 - A voltage source is applied across the device to create an electric field.
 - The resulting transient photocurrent is measured using an oscilloscope.[7]
- Data Acquisition and Analysis:
 - A short laser pulse generates a sheet of charge carriers near the transparent electrode.
 - Under the applied electric field, one type of carrier (in this case, holes) drifts across the PDPB film.
 - The transit time (τ) is determined from the transient photocurrent signal.
 - The hole mobility (μ_h) is then calculated using the equation: $\mu_h = d^2 / (V * \tau)$ where d is the film thickness and V is the applied voltage.

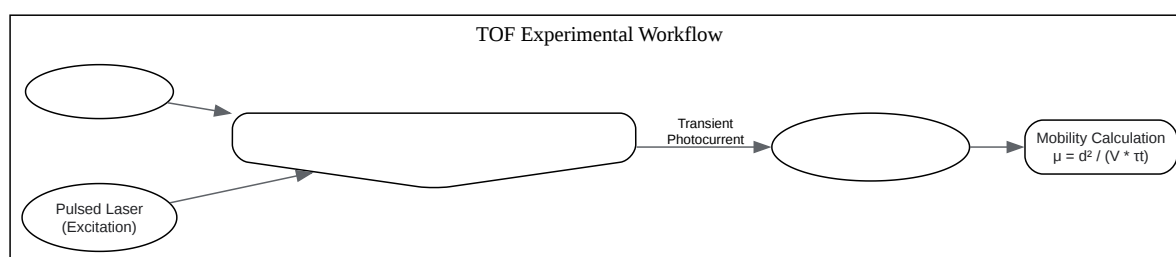

[Click to download full resolution via product page](#)

Caption: Workflow for Time-of-Flight (TOF) Mobility Measurement.

Space-Charge-Limited Current (SCLC) Measurements

The SCLC method is a steady-state measurement that analyzes the current-voltage (J-V) characteristics of a single-carrier device.[9] When the injected charge carrier density exceeds the intrinsic carrier density, the current becomes limited by the space charge of the injected carriers.

- Device Fabrication:
 - A single-carrier (hole-only) device is fabricated. This requires an ohmic contact for hole injection (e.g., a high work function metal or a hole-injection layer) and a blocking contact for electrons.[10]
 - The device structure is typically a sandwich configuration similar to that used for TOF.
- Measurement Setup:
 - A source-measure unit is used to apply a voltage sweep and measure the resulting current.
 - The measurement is performed in the dark to avoid photogeneration of carriers.
- Data Acquisition and Analysis:
 - The current density (J) is measured as a function of the applied voltage (V).
 - The data is plotted on a log-log scale.
 - In the ideal trap-free SCLC regime, the current density follows the Mott-Gurney law:[9] $J = (9/8) * \epsilon_0 * \epsilon_r * \mu_h * (V^2 / d^3)$ where ϵ_0 is the permittivity of free space, ϵ_r is the relative permittivity of the material, μ_h is the hole mobility, V is the voltage, and d is the film thickness.
 - The hole mobility can be extracted from the slope of the J vs. V^2 plot in the SCLC regime.

It is crucial to be aware of potential pitfalls in SCLC measurements, such as the presence of non-ohmic contacts or trap states, which can lead to deviations from the ideal Mott-Gurney behavior and result in inaccurate mobility values.[1][7]

Quantitative Analysis of Charge Transport in PDPB

The hole mobility of PDPB can vary depending on factors such as the specific derivative, molecular weight, film morphology, and measurement technique. Reported values typically fall within a range that makes it suitable for various electronic applications.

Polymer System	Measurement Technique	Reported Hole Mobility (cm ² /Vs)	Reference
Poly-TPD	SCLC	1-2 x 10 ⁻³	[1]
Poly-TPD	SCLC	1.7 x 10 ⁻⁴	[1]
Poly-TPD	SCLC	4 x 10 ⁻⁷	[1]
Poly-TPD	Organic Field-Effect Transistor	1 x 10 ⁻⁴	[1]
Poly(tetraphenylbenzidines) (PTPDs)	SCLC	Independent of molecular weight and side chain polarity in the studied series	[2]

Factors Influencing Charge Transport in PDPB

Several factors can significantly impact the charge transport properties of **poly(diphenylbenzidine)**. Understanding and controlling these factors is key to optimizing device performance.

Doping

Chemical doping is a powerful technique to enhance the conductivity of conducting polymers. [5] For a p-type semiconductor like PDPB, p-doping involves introducing an electron-accepting molecule (a p-dopant) into the polymer matrix. This process has two primary effects:

- Increased Carrier Concentration: The dopant molecules accept electrons from the PDPB chains, creating additional holes and thereby increasing the charge carrier concentration.[2]
- Fermi Level Shift: The introduction of acceptor states shifts the Fermi level of the polymer closer to the HOMO level, which can improve charge injection from the anode.



[Click to download full resolution via product page](#)

Need Custom Synthesis?

BenchChem offers custom synthesis for rare earth carbides and specific isotopic labeling.

Email: info@benchchem.com or [Request Quote Online](#).

Sources

1. pubs.acs.org [pubs.acs.org]
 2. A competitive hopping model for carrier transport in disordered organic semiconductors - Physical Chemistry Chemical Physics (RSC Publishing) [pubs.rsc.org]
 3. 1.3 Theoretical Concepts [iue.tuwien.ac.at]
 4. blog.disorderedmatter.eu [blog.disorderedmatter.eu]
 5. researchgate.net [researchgate.net]
 6. Frontiers | On the importance of varying device thickness and temperature on the outcome of space-charge-limited current measurements [frontiersin.org]
 7. Space Charge Limited Current (SCLC) for Mobility in Organic & Perovskite Semiconductors — Fluxim [fluxim.com]
 8. researchgate.net [researchgate.net]
 9. pubs.aip.org [pubs.aip.org]
 10. researchgate.net [researchgate.net]
- To cite this document: BenchChem. [A Technical Guide to the Charge Transport Mechanism in Poly(diphenylbenzidine)]. BenchChem, [2026]. [Online PDF]. Available at: [<https://www.benchchem.com/product/b12113712/docs#a-technical-guide-to-the-charge-transport-mechanism-in-poly-diphenylbenzidine>]

Disclaimer & Data Validity:

The information provided in this document is for Research Use Only (RUO) and is strictly not intended for diagnostic or therapeutic procedures. While BenchChem strives to provide accurate protocols, we make no warranties, express or implied, regarding the fitness of this product for every specific experimental setup.

Technical Support: The protocols provided are for reference purposes. Unsure if this reagent suits your experiment?

Need Industrial/Bulk Grade? [Request Custom Synthesis Quote](#)

BenchChem

Our mission is to be the trusted global source of essential and advanced chemicals, empowering scientists and researchers to drive progress in science and industry.

Contact

Address: 3281 E Guasti Rd

Ontario, CA 91761, United States

Phone: (601) 213-4426

Email: info@benchchem.com

[Contact our Ph.D. Support Team for a compatibility check](#)