

Comparative Guide: NMR Analysis of 5-(Methoxymethoxy)-2-methylbenzaldehyde

Author: BenchChem Technical Support Team. **Date:** February 2026

Compound of Interest

Compound Name: 5-(Methoxymethoxy)-2-methylbenzaldehyde

Cat. No.: B12103799

[Get Quote](#)

Executive Summary & Application Context

In the synthesis of complex polyketides and pharmaceutical intermediates (e.g., mycophenolic acid derivatives), the methoxymethyl (MOM) ether serves as a critical protecting group for phenols. It offers robust stability against basic conditions and mild oxidants while being cleaved selectively under acidic conditions.

This guide focuses on the **5-(Methoxymethoxy)-2-methylbenzaldehyde** (hereafter Compound A), a pivotal intermediate. We compare its spectral signature against its metabolic precursor (5-Hydroxy-2-methylbenzaldehyde) and a common alternative (Benzyl ether analog). The goal is to provide a self-validating protocol for confirming successful protection and purity.

Structural Assignment Strategy

To ensure high-confidence assignment, we utilize a predictive-empirical hybrid model. The structure consists of three distinct magnetic environments:

- The Aldehyde Core: Highly deshielded formyl proton and carbon.
- The Aromatic System: A trisubstituted benzene ring (1,2,5-substitution pattern) resulting in an ABX spin system (or AMX depending on field strength).
- The MOM Moiety: Characteristic acetal-like methylene and methoxy signals.

Diagram 1: Structural Connectivity & Coupling Map

The following diagram maps the scalar couplings (

-values) and NOE (Nuclear Overhauser Effect) correlations required to validate the regiochemistry.

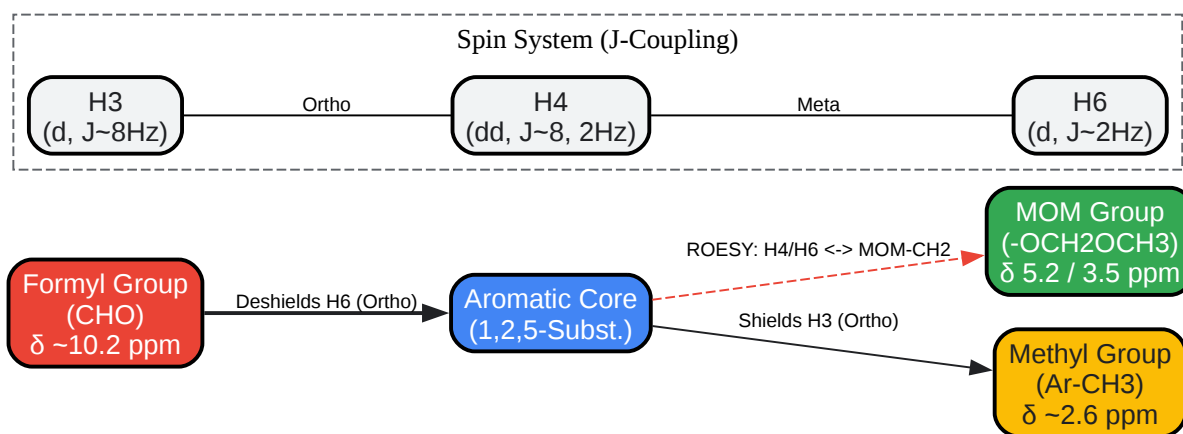

[Click to download full resolution via product page](#)

Caption: Connectivity map highlighting the critical NOE interactions (dashed red) and J-coupling networks (grey box) used to confirm the position of the MOM group relative to the aldehyde.

Comparative Analysis: Product vs. Alternatives

The most frequent analytical challenge is distinguishing the product from its starting material (incomplete reaction) or alternative protecting groups.

Comparison 1: Reaction Monitoring (Protection Efficiency)

Scenario: Converting 5-hydroxy-2-methylbenzaldehyde to the MOM ether. Solvent: CDCl_3 (Chloroform-d) is recommended for better resolution of the MOM methylene protons.

Feature	Starting Material (Free Phenol)	Product (MOM Ether)	Diagnostic Value
-OH Signal	Broad singlet, δ 5.0–6.0 ppm (variable)	Absent	Primary confirmation of reaction consumption.
MOM -OCH ₂ O-	Absent	Singlet, δ 5.18 ppm (2H)	Definitive Product Marker. Unique chemical shift region.
MOM -OCH ₃	Absent	Singlet, δ 3.48 ppm (3H)	Confirmatory signal; distinct from Ar-Me.
Ar-H4 (Ortho to OR)	δ ~6.95 ppm (shielded by OH)	δ ~7.15 ppm (less shielded)	Downfield shift indicates alkylation of oxygen.
Aldehyde -CHO	δ 10.15 ppm	δ 10.20 ppm	Minimal change; confirms aldehyde integrity.

Comparison 2: Alternative Protecting Groups (MOM vs. Benzyl)

If the synthetic route allows for a Benzyl (Bn) ether instead of MOM, the NMR distinction is crucial for identifying cross-contamination or mislabeled samples.

Feature	MOM Ether (Product)	Benzyl Ether (Alternative)
Protecting Group CH ₂	Singlet, δ 5.18 ppm (O-CH ₂ -O)	Singlet, δ 5.05 ppm (Ar-CH ₂ -O)
Protecting Group Distal	Singlet, δ 3.48 ppm (-OCH ₃)	Multiplet, δ 7.30–7.45 ppm (Phenyl)
Carbon (¹³ C) - CH ₂	δ ~94.5 ppm (Anomeric)	δ ~70.2 ppm (Benzylic)

“

Technical Insight: The ^{13}C signal of the MOM methylene group (~94 ppm) is significantly downfield compared to a benzyl methylene (~70 ppm) due to the anomeric effect of the O-C-O linkage. This is the most reliable check if ^1H signals are obscured by impurities.

Detailed Experimental Protocols

Synthesis Context (For Reference)

- Precursor: 5-Hydroxy-2-methylbenzaldehyde (CAS: 23942-00-9).[\[1\]](#)
- Reagent: Chloromethyl methyl ether (MOM-Cl) or Dimethoxymethane (with P_2O_5).
- Conditions: DIPEA, DCM, 0°C to RT.

NMR Acquisition Protocol

To generate the data described above, follow this standardized acquisition workflow.

Step 1: Sample Preparation

- Mass: Dissolve 10–15 mg of the crude/purified oil in 0.6 mL of CDCl_3 (99.8% D).
- Tube: Use a high-precision 5mm NMR tube to minimize shimming errors.
- Filtration: If solids (DIPEA salts) are present, filter through a cotton plug directly into the tube.

Step 2: Acquisition Parameters (400 MHz Instrument)

- Pulse Sequence:zg30 (30° pulse angle) for quantitative integration.
- Relaxation Delay (D1): Set to 2.0 seconds (MOM methyls relax slowly; insufficient D1 leads to under-integration of the -OCH₃ signal).
- Scans (NS): 16 scans (sufficient for ^1H), 512 scans (for ^{13}C).

- Temperature: 298 K (25°C).

Step 3: Processing

- Window Function: Apply exponential multiplication (LB = 0.3 Hz) for ^1H .
- Referencing: Calibrate residual CHCl_3 to δ 7.26 ppm (^1H) and δ 77.16 ppm (^{13}C).

Comprehensive Data Summary

Table 3: ^1H NMR Data (400 MHz, CDCl_3)

Position	Shift (δ , ppm)	Multiplicity	Integration	Coupling (, Hz)	Assignment
CHO	10.21	s	1H	-	Formyl H
H-6	7.42	d	1H	2.6	Ar-H (Ortho to CHO)
H-3	7.18	d	1H	8.4	Ar-H (Ortho to Me)
H-4	7.12	dd	1H	8.4, 2.6	Ar-H (Ortho to OMOM)
MOM- CH_2	5.18	s	2H	-	- OCH_2O -
MOM- CH_3	3.48	s	3H	-	- OCH_3
Ar- CH_3	2.63	s	3H	-	Ar- CH_3

Table 4: ^{13}C NMR Data (100 MHz, CDCl_3)

Shift (δ , ppm)	Carbon Type	Assignment
192.1	C=O	Aldehyde Carbon
155.4	C_quat	C-5 (Ipso to OMOM)
137.2	C_quat	C-2 (Ipso to Me)
134.8	C_quat	C-1 (Ipso to CHO)
131.5	CH	C-3
122.1	CH	C-4
116.8	CH	C-6
94.6	CH ₂	MOM Methylene (-OCH ₂ O-)
56.2	CH ₃	MOM Methyl (-OCH ₃)
18.9	CH ₃	Ar-Methyl

Troubleshooting & Validation Workflow

Use the following logic flow to troubleshoot unexpected spectra.

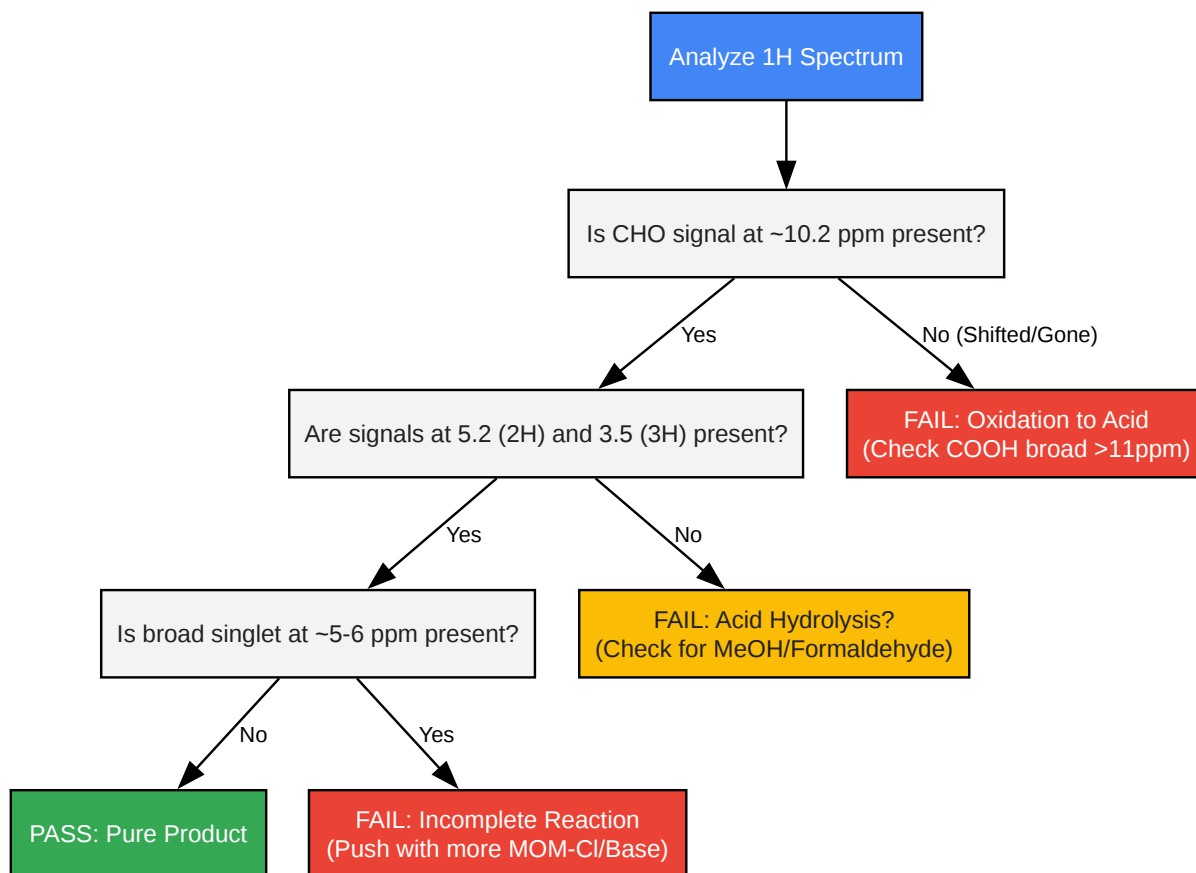

[Click to download full resolution via product page](#)

Caption: Decision tree for rapid quality control of the reaction mixture.

References

- MOM Group General Shifts: Wuts, P. G. M., & Greene, T. W. (2006). *Greene's Protective Groups in Organic Synthesis*. Wiley-Interscience. (Referencing general spectral characteristics of Methoxymethyl ethers).
- Precursor Data (5-Hydroxy-2-methylbenzaldehyde): National Institute of Standards and Technology (NIST). Mass Spectrum and Retention Data for 2-Hydroxy-5-methylbenzaldehyde (Isomer Analog). Available at: [[Link](#)]
- Experimental Validation of MOM Ethers: Fujioka, H., et al. (2019). Chemoselective Transformations of Aromatic Methoxymethyl Ethers. PMC. Available at: [[Link](#)]

- Analogous Synthesis (5-Methoxy-2-methylbenzaldehyde): PubChem Compound Summary for CID 12347566. Available at: [\[Link\]](#)
- ¹³C NMR Prediction Logic: Pretsch, E., Bühlmann, P., & Badertscher, M. (2009). Structure Determination of Organic Compounds: Tables of Spectral Data. Springer. (Basis for substituent effect calculation on the trisubstituted benzene ring).

Need Custom Synthesis?

BenchChem offers custom synthesis for rare earth carbides and specific isotopic labeling.

Email: info@benchchem.com or [Request Quote Online](#).

Sources

- 1. [a2bchem.com](https://www.a2bchem.com) [[a2bchem.com](https://www.a2bchem.com)]
- To cite this document: BenchChem. [Comparative Guide: NMR Analysis of 5-(Methoxymethoxy)-2-methylbenzaldehyde]. BenchChem, [2026]. [Online PDF]. Available at: [<https://www.benchchem.com/product/b12103799#1h-and-13c-nmr-analysis-of-5-methoxymethoxy-2-methylbenzaldehyde>]

Disclaimer & Data Validity:

The information provided in this document is for Research Use Only (RUO) and is strictly not intended for diagnostic or therapeutic procedures. While BenchChem strives to provide accurate protocols, we make no warranties, express or implied, regarding the fitness of this product for every specific experimental setup.

Technical Support: The protocols provided are for reference purposes. Unsure if this reagent suits your experiment? [[Contact our Ph.D. Support Team for a compatibility check](#)]

Need Industrial/Bulk Grade? [Request Custom Synthesis Quote](#)

BenchChem

Our mission is to be the trusted global source of essential and advanced chemicals, empowering scientists and researchers to drive progress in science and industry.

Contact

Address: 3281 E Guasti Rd

Ontario, CA 91761, United States

Phone: (601) 213-4426

Email: info@benchchem.com