

# Part 1: Foundational Knowledge & Supplier Landscape

**Author:** BenchChem Technical Support Team. **Date:** May 2026

## Compound of Interest

Compound Name: Cy3 azide  
Cat. No.: B12100619

[Get Quote](#)

## The Role of Cy3 Azide in Modern Bioconjugation

**Cy3 azide** is a fluorescent probe belonging to the cyanine dye family, functionalized with an azide ( $-N_3$ ) group. This azide moiety is the key to its utility, enabling it to participate in "click chemistry" reactions, one of the most efficient and bio-orthogonal conjugation methods available.[1][2] Specifically, **Cy3 azide** is a critical reagent for the Copper(I)-Catalyzed Azide-Alkyne Cycloaddition (CuAAC), a reaction that forms a stable triazole linkage between the azide-functionalized dye and an alkyne-modified biomolecule.[1][3][4]

The Cy3 fluorophore is characterized by its bright orange-red fluorescence, with an excitation maximum around 555 nm and an emission maximum near 570 nm.[5][6][7] Its high extinction coefficient makes it easily detectable, even by the naked eye in concentrated solutions, and it is compatible with a wide range of common fluorescence imaging instruments.[8] This combination of a robust conjugation handle and a bright, stable fluorophore makes **Cy3 azide** an indispensable tool for labeling and visualizing proteins, nucleic acids, and other biomolecules in applications ranging from microscopy and flow cytometry to ELISA and Western blotting.[9]

## Key Physicochemical Properties

A thorough understanding of **Cy3 azide**'s properties is crucial for its effective use. While minor variations exist between suppliers, the core characteristics are consistent.

- Spectroscopic Properties:
  - Excitation Maximum ( $\lambda_{\text{abs}}$ ): ~553-555 nm[10][11]
  - Emission Maximum ( $\lambda_{\text{em}}$ ): ~569-570 nm[10][11]
  - Molar Extinction Coefficient ( $\epsilon$ ): ~150,000 M<sup>-1</sup>cm<sup>-1</sup>[5][7][10]
- Solubility: Standard, non-sulfonated **Cy3 azide** is generally insoluble in water but soluble in organic solvents like Dimethyl sulfoxide (DMSO) and Dimethylformamide (DMF).[6][7][8] This necessitates the use of an organic co-solvent for labeling reactions in aqueous buffers.[8][12]
- Storage and Stability: **Cy3 azide** should be stored at -20°C, desiccated, and protected from light.[5][7][8] Suppliers indicate stability for 12-24 months under these conditions.[7][8][12] It can typically be shipped at ambient temperature for short durations (up to 3 weeks) without compromising its integrity.[8][12]

## The Supplier Landscape: A Comparative Analysis

Selecting a supplier involves evaluating more than just price. Purity, formulation, and available technical support are critical. Below is a summary of prominent suppliers and their offerings.

Supplier	Product Name/Variant	Purity	Key Features & Notes
BroadPharm	Cy3 Azide	>95%	Offers various quantities (5 mg to 50 mg) and notes GMP-grade inquiries are possible. <a href="#">[5]</a>
Jena Bioscience	Cy3-Azide	≥ 90% (HPLC)	Provides detailed spectroscopic properties and specifies solubility in DMF, DMSO, and Dichloromethane. <a href="#">[7]</a>
Lumiprobe	Cyanine3 azide	Not specified	Offers the product as a solid or a ready-to-use 10 mM solution in DMSO. <a href="#">[8]</a> Highlights the availability of a water-soluble version. <a href="#">[8]</a>
Vector Labs	Cy3 Azide	>95% (HPLC)	Notes the product is water-soluble and compatible with both copper-catalyzed and copper-free (SPAAC) click chemistry. <a href="#">[10]</a> <a href="#">[13]</a>
AAT Bioquest	Cyanine 3 azide / FastClick™ Cy3 Azide	Not specified	Offers a standard Cy3 azide and a "FastClick™" version containing a copper-chelating ligand to accelerate the reaction. <a href="#">[14]</a> <a href="#">[15]</a>

Sigma-Aldrich	Cy3-azide	90% (HPLC)	Provides detailed safety and handling information.
APEXBio	Cy3 azide (non-sulfonated) / Sulfo-Cy3 Azide	Not specified	Clearly distinguishes between the non-sulfonated version requiring co-solvents and the highly water-soluble sulfonated version. <a href="#">[12]</a> <a href="#">[16]</a>

## Part 2: Procurement & Quality Control

### Making an Informed Purchase: Beyond the Catalog

The choice between different **Cy3 azide** variants is a critical experimental decision.

- **Standard (Non-sulfonated) Cy3 Azide:** This is the most common and cost-effective form. It is ideal for labeling oligonucleotides or proteins that are tolerant to small amounts of organic co-solvents (e.g., DMSO).[\[8\]](#)[\[12\]](#) The final concentration of DMSO in the reaction should be carefully optimized to ensure the solubility of the dye without denaturing the target biomolecule.
- **Sulfonated (Water-Soluble) Cy3 Azide:** Variants like Sulfo-**Cy3 azide** contain sulfonate groups that impart high hydrophilicity.[\[16\]](#) This is a significant advantage when working with sensitive proteins or in live-cell labeling experiments where organic solvents could compromise biological integrity.[\[16\]](#) These versions eliminate the need for co-solvents, simplifying the reaction setup.[\[10\]](#)[\[16\]](#)
- **Formulation:** Purchasing the dye as a pre-weighed solid offers flexibility in preparing stock solutions at desired concentrations. However, for convenience and to avoid handling small powder quantities, some suppliers offer a pre-dissolved 10 mM solution in DMSO.[\[8\]](#)

### Quality Control: The Importance of the Certificate of Analysis (CoA)

Upon receiving the product, always review the Certificate of Analysis. Key parameters to check include:

- **Purity:** Look for purity confirmed by High-Performance Liquid Chromatography (HPLC), which should ideally be >90-95%.<sup>[7][10]</sup> Impurities can lead to high background fluorescence or side reactions.
- **Identity Confirmation:** The CoA should confirm the compound's identity, often through mass spectrometry, verifying the correct molecular weight.
- **Appearance:** The product should be a red or pink solid, as described by suppliers.<sup>[7][10]</sup>

Proper handling upon receipt is crucial. Ensure the vial is brought to room temperature before opening to prevent condensation of moisture onto the hygroscopic solid. Store immediately at -20°C, protected from light.<sup>[7][8]</sup>

## Part 3: Core Application Protocol: CuAAC Labeling of an Alkyne-Modified Protein

This section provides a robust, self-validating protocol for labeling an alkyne-modified protein with **Cy3 azide**. The causality behind each step is explained to empower the researcher to adapt the protocol as needed.

### The Chemistry of Connection

The CuAAC reaction is a highly efficient and specific cycloaddition between the terminal nitrogen atoms of the azide and the carbon atoms of the alkyne.<sup>[17]</sup> The reaction is catalyzed by Copper in its +1 oxidation state (Cu(I)).<sup>[1][18]</sup> Because Cu(I) is unstable and readily oxidizes to Cu(II), the reaction is typically run using a Cu(II) salt (e.g., CuSO<sub>4</sub>) and a reducing agent (e.g., sodium ascorbate) to generate the active Cu(I) catalyst in situ.<sup>[1][18][19]</sup>

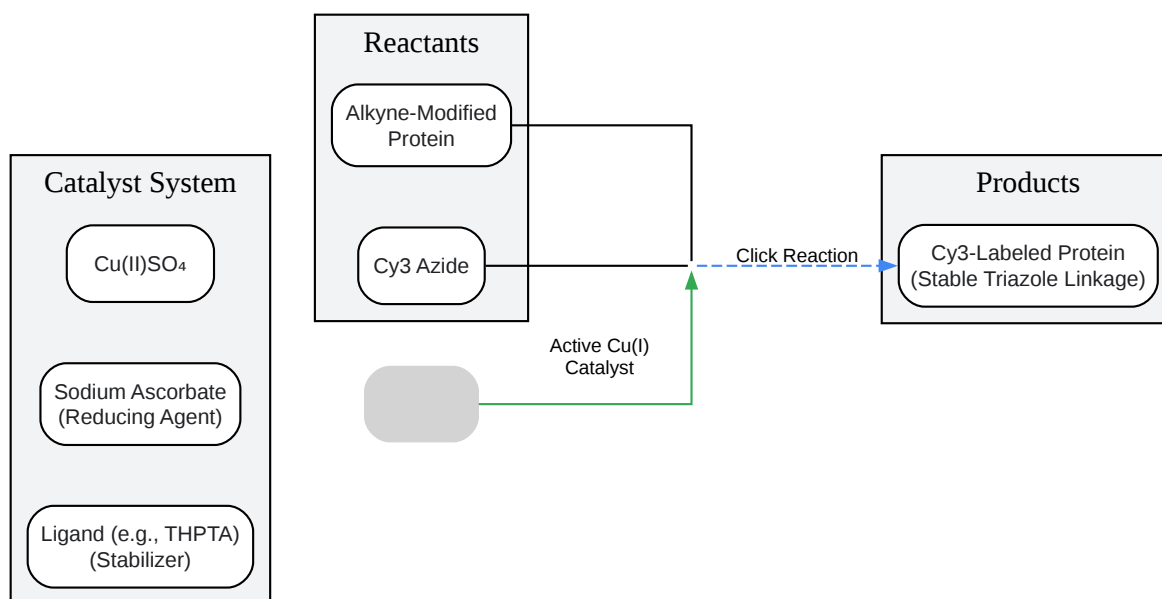

[Click to download full resolution via product page](#)

**Caption:** Conceptual workflow of the CuAAC reaction components.

## Step-by-Step Experimental Workflow

This protocol is optimized for labeling ~1 mg of protein. Adjust volumes proportionally for different amounts.

### A. Preparation of Stock Solutions

- **Protein Preparation:** Ensure the alkyne-modified protein is in an amine-free buffer (e.g., PBS, HEPES) at a concentration of 5-10 mg/mL.<sup>[9][20]</sup> Buffers containing primary amines like Tris will interfere with some labeling chemistries and should be avoided.<sup>[9]</sup>
- **Cy3 Azide (10 mM):** Dissolve 1 mg of **Cy3 azide** (MW will vary by supplier, check CoA) in the appropriate volume of anhydrous DMSO to make a 10 mM stock. Vortex thoroughly. Store any unused portion at -20°C.

- Copper(II) Sulfate (100 mM): Dissolve ~25 mg of  $\text{CuSO}_4 \cdot 5\text{H}_2\text{O}$  in 1 mL of deionized water. This solution is stable at room temperature.[18]
- Ligand (e.g., THPTA) (200 mM): Prepare a 200 mM stock of a water-soluble Cu(I)-stabilizing ligand like THPTA in water.[18] The ligand is critical as it protects the protein from damage by reactive oxygen species generated during the reaction and accelerates the conjugation.[19]
- Sodium Ascorbate (100 mM):Crucially, this solution must be prepared fresh immediately before use. Dissolve ~20 mg of sodium ascorbate in 1 mL of deionized water. Ascorbate solutions oxidize rapidly in air and lose potency.[21][22]

## B. The Labeling Reaction

- In a microcentrifuge tube, combine the following in order:
  - 100  $\mu\text{L}$  of alkyne-modified protein (~1 mg)
  - An appropriate volume of **Cy3 Azide** stock. A 3-10 fold molar excess of dye over protein is a good starting point.[21] (e.g., for a 50 kDa protein, this is ~20 nmol, so use 6-20  $\mu\text{L}$  of 10 mM dye stock).
  - An appropriate volume of Ligand/ $\text{CuSO}_4$  pre-mix. Pre-mix the THPTA and  $\text{CuSO}_4$  solutions at a 2:1 ratio (e.g., 2  $\mu\text{L}$  of 200 mM THPTA and 1  $\mu\text{L}$  of 100 mM  $\text{CuSO}_4$ ) and let it stand for a few minutes.[18] Add this pre-mix to the protein solution.
- Vortex the mixture gently.
- Initiate the reaction by adding the freshly prepared sodium ascorbate solution. A final concentration of 1-5 mM is typically sufficient.
- Incubate the reaction at room temperature for 1-2 hours, protected from light.[16] For sensitive proteins, the reaction can be performed at 4°C overnight.

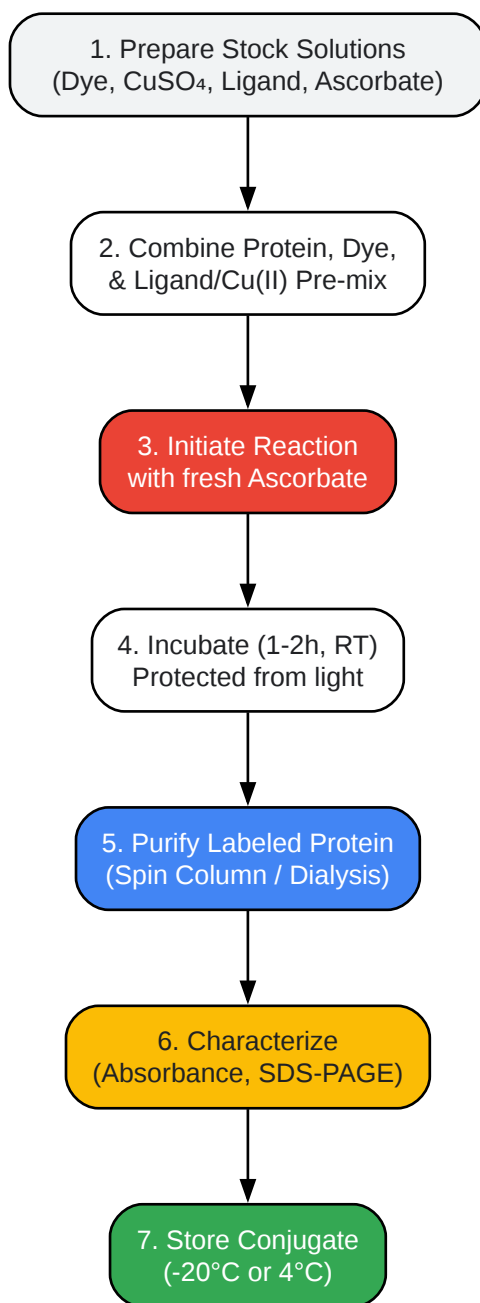

[Click to download full resolution via product page](#)

**Caption:** Step-by-step experimental workflow for protein labeling.

### C. Purification of the Labeled Protein

It is essential to remove unreacted dye and copper catalyst.

- Spin Desalting Columns: For rapid purification of proteins >5 kDa, spin columns are highly effective.[9] Equilibrate the column according to the manufacturer's instructions, then apply the reaction mixture and centrifuge to elute the purified, labeled protein.
- Dialysis: For larger volumes or when a spin column is not suitable, dialyze the reaction mixture against an appropriate buffer (e.g., PBS) overnight at 4°C with several buffer changes.

#### D. Characterization and Storage

- Degree of Labeling (DOL): Measure the absorbance of the purified conjugate at 280 nm (for protein) and 550 nm (for Cy3). The DOL can be calculated using the Beer-Lambert law and a correction factor for the dye's absorbance at 280 nm.[9]
- SDS-PAGE: Run the labeled protein on an SDS-PAGE gel. The labeled protein can be visualized under a fluorescent gel imager, confirming that the fluorescence co-migrates with the protein band.
- Storage: Store the purified conjugate at 4°C for short-term use or at -20°C in aliquots containing a cryoprotectant like glycerol for long-term storage.[9]

## Part 4: Troubleshooting & Advanced Considerations

Problem	Potential Cause(s)	Recommended Solution(s)
Low or No Labeling	Inactive Sodium Ascorbate	Always prepare the sodium ascorbate solution fresh just before use. <a href="#">[22]</a>
Inefficient Catalyst System	Ensure the presence of a stabilizing ligand (e.g., THPTA, TBTA). <a href="#">[16]</a> <a href="#">[18]</a> Optimize copper concentration; too little may limit the reaction rate. <a href="#">[16]</a>	
Inaccessible Alkyne Group	The alkyne group on the protein may be sterically hindered. Consider redesigning the protein construct if possible.	
High Background Fluorescence	Insufficient Purification	Repeat the purification step (spin column or dialysis) to ensure all free dye is removed.
Non-specific Dye Binding	For non-sulfonated dyes, aggregation and precipitation can occur. <a href="#">[16]</a> Ensure the dye is fully dissolved and consider switching to a water-soluble sulfo-Cy3 azide.	
Protein Precipitation	Denaturation by Co-solvent	If using non-sulfonated Cy3 azide, minimize the final DMSO/DMF concentration. Alternatively, use a water-soluble sulfo-Cy3 azide to eliminate the need for organic solvents. <a href="#">[16]</a>
Copper-induced Aggregation	The stabilizing ligand should minimize this, but ensure it is present in sufficient excess	

(e.g., 2-5 fold over copper).[18]

[19]

---

### Advanced Consideration: Copper-Free Click Chemistry

For applications involving live cells or copper-sensitive systems, an alternative is Strain-Promoted Azide-Alkyne Cycloaddition (SPAAC). This reaction uses a strained cyclooctyne (e.g., DBCO, BCN) instead of a simple alkyne. The ring strain is sufficient to drive the reaction with an azide without any copper catalyst.[10][13] Several suppliers, such as Vector Labs, offer **Cy3 azide** that is also validated for this copper-free approach.[10][13]

## References

- Recommended protocols / Click chemistry labeling of oligonucleotides and DNA. Cyan Dye. [\[Link\]](#)
- **Cy3 Azide** - Fluorescent Dyes & Quenchers. GeneToProtein. [\[Link\]](#)
- Cy3-Azide, Azides of Fluorescent Dyes. Jena Bioscience. [\[Link\]](#)
- Click Chemistry Azide-Alkyne Cycloaddition. Organic Chemistry Portal. [\[Link\]](#)
- Cy3-Azide, Azide-containing Fluorescent Dyes. Jena Bioscience. [\[Link\]](#)
- Fluorescent Reagents for Bioconjugation. Creative Biolabs. [\[Link\]](#)
- Protein Cy3 Labeling Kit (#BN01054). Assay Genie. [\[Link\]](#)
- MATERIALS SAFETY DATA SHEET. DC Chemicals. [\[Link\]](#)
- Cy3 Dyes. Biocompare. [\[Link\]](#)
- Fluorescent & Luminescent Conjugates. Fleet Bioprocessing. [\[Link\]](#)
- Click Chemistry: new protocol for the labeling and modification of biomolecules. Interchim. [\[Link\]](#)
- Cy3 Protein Labeling Kit. Jena Bioscience. [\[Link\]](#)

- Copper-Catalyzed Azide–Alkyne Click Chemistry for Bioconjugation. SciSpace. [[Link](#)]
- Fluorescent Dyes and Probes. Bio-Techne. [[Link](#)]
- The copper(I)-catalyzed azide-alkyne cycloaddition (CuAAC). Glen Research. [[Link](#)]
- Copper-catalyzed azide–alkyne cycloaddition (CuAAC) and beyond: new reactivity of copper(i) acetylides. National Center for Biotechnology Information. [[Link](#)]
- Protein labeling protocol. Abberior Instruments. [[Link](#)]
- Problems and Solutions in Click Chemistry Applied to Drug Probes. National Center for Biotechnology Information. [[Link](#)]

### Need Custom Synthesis?

BenchChem offers custom synthesis for rare earth carbides and specific isotopic labeling.

Email: [info@benchchem.com](mailto:info@benchchem.com) or [Request Quote Online](#).

## Sources

1. Click Chemistry [[organic-chemistry.org](http://organic-chemistry.org)]
2. [interchim.fr](http://interchim.fr) [[interchim.fr](http://interchim.fr)]
3. [bioconjugation.bocsci.com](http://bioconjugation.bocsci.com) [[bioconjugation.bocsci.com](http://bioconjugation.bocsci.com)]
4. Copper-catalyzed azide–alkyne cycloaddition (CuAAC) and beyond: new reactivity of copper(i) acetylides - PMC [[pmc.ncbi.nlm.nih.gov](http://pmc.ncbi.nlm.nih.gov)]
5. Cy3 Azide, 1167421-28-4 | BroadPharm [[broadpharm.com](http://broadpharm.com)]
6. Cy3 Azide - Fluorescent Dyes & Quenchers - Products - GeneToProtein [[genetoprotein.com](http://genetoprotein.com)]
7. Cy3-Azide, Azides of Fluorescent Dyes - Jena Bioscience [[jenabioscience.com](http://jenabioscience.com)]
8. [lumiprobe.com](http://lumiprobe.com) [[lumiprobe.com](http://lumiprobe.com)]
9. [assaygenie.com](http://assaygenie.com) [[assaygenie.com](http://assaygenie.com)]
10. [vectorlabs.com](http://vectorlabs.com) [[vectorlabs.com](http://vectorlabs.com)]
11. Cy3-Azide, Azide-containing Fluorescent Dyes - Jena Bioscience [[jenabioscience.com](http://jenabioscience.com)]

- [12. apexbt.com \[apexbt.com\]](#)
- [13. vectorlabs.com \[vectorlabs.com\]](#)
- [14. FastClick™ Cy3 Azide | AAT Bioquest \[aatbio.com\]](#)
- [15. Cyanine 3 azide \[equivalent to Cy3® azide\] | AAT Bioquest \[aatbio.com\]](#)
- [16. sulfo-cy3-azide.com \[sulfo-cy3-azide.com\]](#)
- [17. glenresearch.com \[glenresearch.com\]](#)
- [18. broadpharm.com \[broadpharm.com\]](#)
- [19. scispace.com \[scispace.com\]](#)
- [20. Cy3 Protein Labeling Kit, Fluorescent Amine Protein Labeling - Jena Bioscience \[jenabioscience.com\]](#)
- [21. lumiprobe.com \[lumiprobe.com\]](#)
- [22. lumiprobe.com \[lumiprobe.com\]](#)
- To cite this document: BenchChem. [Part 1: Foundational Knowledge & Supplier Landscape]. BenchChem, [2026]. [Online PDF]. Available at: [\[https://www.benchchem.com/product/b12100619/docs#part-1-foundational-knowledge-supplier-landscape\]](https://www.benchchem.com/product/b12100619/docs#part-1-foundational-knowledge-supplier-landscape)

---

### Disclaimer & Data Validity:

The information provided in this document is for Research Use Only (RUO) and is strictly not intended for diagnostic or therapeutic procedures. While BenchChem strives to provide accurate protocols, we make no warranties, express or implied, regarding the fitness of this product for every specific experimental setup.

**Technical Support:** The protocols provided are for reference purposes. Unsure if this reagent suits your experiment?

**Need Industrial/Bulk Grade?** [Request Custom Synthesis Quote](#)

# BenchChem

Our mission is to be the trusted global source of essential and advanced chemicals, empowering scientists and researchers to drive progress in science and industry.

## Contact

Address: 3281 E Guasti Rd

Ontario, CA 91761, United States

Phone: (601) 213-4426

Email: [info@benchchem.com](mailto:info@benchchem.com)

[Contact our Ph.D. Support Team for a compatibility check](#)