

Exploring the Antipsychotic Potential of BD-1047: A Technical Guide

Author: BenchChem Technical Support Team. **Date:** April 2026

Compound of Interest

Compound Name: *BD-1047*
CAS No.: *138356-20-4*
Cat. No.: *B1210693*

[Get Quote](#)

For Researchers, Scientists, and Drug Development Professionals

Introduction

BD-1047, a selective sigma-1 (σ_1) receptor antagonist, has been investigated for its potential as a novel antipsychotic agent. The sigma-1 receptor, a unique intracellular chaperone protein located at the endoplasmic reticulum-mitochondrion interface, is implicated in the modulation of various neurotransmitter systems, including the dopaminergic and glutamatergic pathways, which are known to be dysregulated in psychotic disorders such as schizophrenia. This technical guide provides a comprehensive overview of the preclinical data available for **BD-1047**, focusing on its receptor binding profile, efficacy in predictive animal models of psychosis, and the experimental protocols used for its evaluation.

Data Presentation

The following tables summarize the quantitative data available for **BD-1047**, providing a clear comparison of its binding affinities and its effects in various preclinical models.

Table 1: Receptor Binding Affinity of BD-1047

Receptor Subtype	K _i (nM)	Selectivity (σ_2/σ_1)
Sigma-1 (σ_1)	0.9 - 0.93	~51-52
Sigma-2 (σ_2)	47	

K_i values represent the dissociation constant, with lower values indicating higher binding affinity.

Table 2: Preclinical In Vivo Efficacy of BD-1047 in Models of Psychosis

Animal Model	Species	Behavioral Endpoint	BD-1047 Dosage (mg/kg, i.p.)	Outcome	Citation
Amphetamine-Induced Hyperactivity	Mouse	Locomotor Activity	Not specified	No statistically significant decrease in hyperactivity.	[1][2]
NMDA Antagonist (PCP, Memantine, Dizocilpine)-Induced Hyperactivity	Mouse	Locomotor Activity	Not specified	Did not modify hyperactivity.	[1][2]
Apomorphine-Induced Climbing	Mouse	Climbing Behavior	10	Attenuated climbing behavior.[3]	[1][2][3][4]
Phencyclidine (PCP)-Induced Head Twitches	Rat	Head Twitch Response	Not specified	Attenuated head twitches.	[1][2][4]

Note: Detailed dose-response data, such as ED50 values, for the in vivo models are not readily available in the cited literature. The presented findings are based on the effective doses reported in these studies.

Experimental Protocols

Detailed methodologies for the key preclinical models used to assess the antipsychotic potential of **BD-1047** are provided below. These protocols are synthesized from standard practices in psychopharmacological research.

Protocol 1: Amphetamine-Induced Hyperactivity in Mice

Objective: To assess the potential of a test compound to reverse the hyperlocomotor activity induced by the psychostimulant amphetamine, a widely used screening method for antipsychotic drugs.

Materials:

- Male Swiss Webster mice (20-25 g)
- d-Amphetamine sulfate
- Test compound (**BD-1047**)
- Vehicle (e.g., saline, 0.5% methylcellulose)
- Open-field activity chambers equipped with infrared beams

Procedure:

- Acclimation: Mice are acclimated to the testing room for at least 1 hour before the experiment.
- Habituation: Individual mice are placed in the open-field chambers and allowed to habituate for 30-60 minutes.
- Drug Administration:
 - The test compound (**BD-1047**) or vehicle is administered via intraperitoneal (i.p.) injection.
 - After a specified pretreatment time (e.g., 30 minutes), d-amphetamine (e.g., 1-5 mg/kg) is administered (i.p. or s.c.).
- Data Collection: Locomotor activity (e.g., total distance traveled, number of beam breaks) is recorded for 60-90 minutes immediately following amphetamine administration.
- Data Analysis: The mean locomotor activity is calculated for each treatment group. Statistical analysis (e.g., ANOVA followed by post-hoc tests) is used to compare the locomotor activity

of the **BD-1047** treated group to the vehicle-amphetamine control group. A significant reduction in hyperactivity by the test compound is indicative of potential antipsychotic efficacy.

Protocol 2: Apomorphine-Induced Climbing in Mice

Objective: To evaluate the ability of a test compound to inhibit the stereotyped climbing behavior induced by the dopamine receptor agonist apomorphine. This model is particularly sensitive to compounds with D2 receptor blocking activity.

Materials:

- Male ICR or Swiss Webster mice (20-25 g)
- Apomorphine hydrochloride
- Test compound (**BD-1047**)
- Vehicle
- Cylindrical wire mesh cages (e.g., 10 cm diameter, 15 cm height)

Procedure:

- Acclimation: Mice are acclimated to the testing room for at least 1 hour.
- Drug Administration: The test compound (**BD-1047**) or vehicle is administered (i.p.) at a specified pretreatment time (e.g., 30-60 minutes) before the apomorphine challenge.
- Apomorphine Challenge: Apomorphine (e.g., 1-3 mg/kg) is administered subcutaneously (s.c.).
- Observation: Immediately after apomorphine injection, mice are placed individually in the wire mesh cages. The climbing behavior is observed for a period of 20-30 minutes.
- Scoring: The duration of time spent climbing (all four paws on the wall of the cage) is recorded. Alternatively, a scoring system can be used at fixed intervals (e.g., every 5 minutes).

- Data Analysis: The total time spent climbing or the cumulative climbing score is calculated for each mouse. The mean values for each treatment group are compared using appropriate statistical methods (e.g., ANOVA). A significant reduction in climbing behavior suggests potential antipsychotic activity.

Mandatory Visualizations

Signaling Pathways

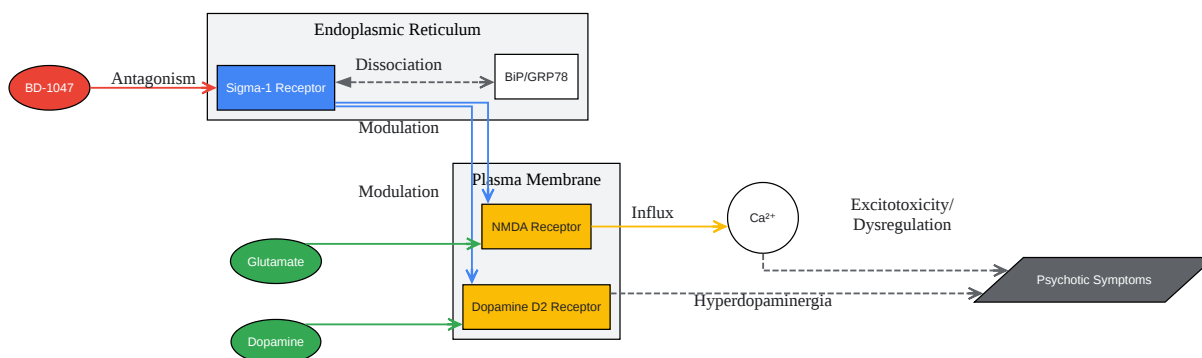

[Click to download full resolution via product page](#)

Caption: Proposed mechanism of **BD-1047** via Sigma-1 receptor antagonism.

Experimental Workflow

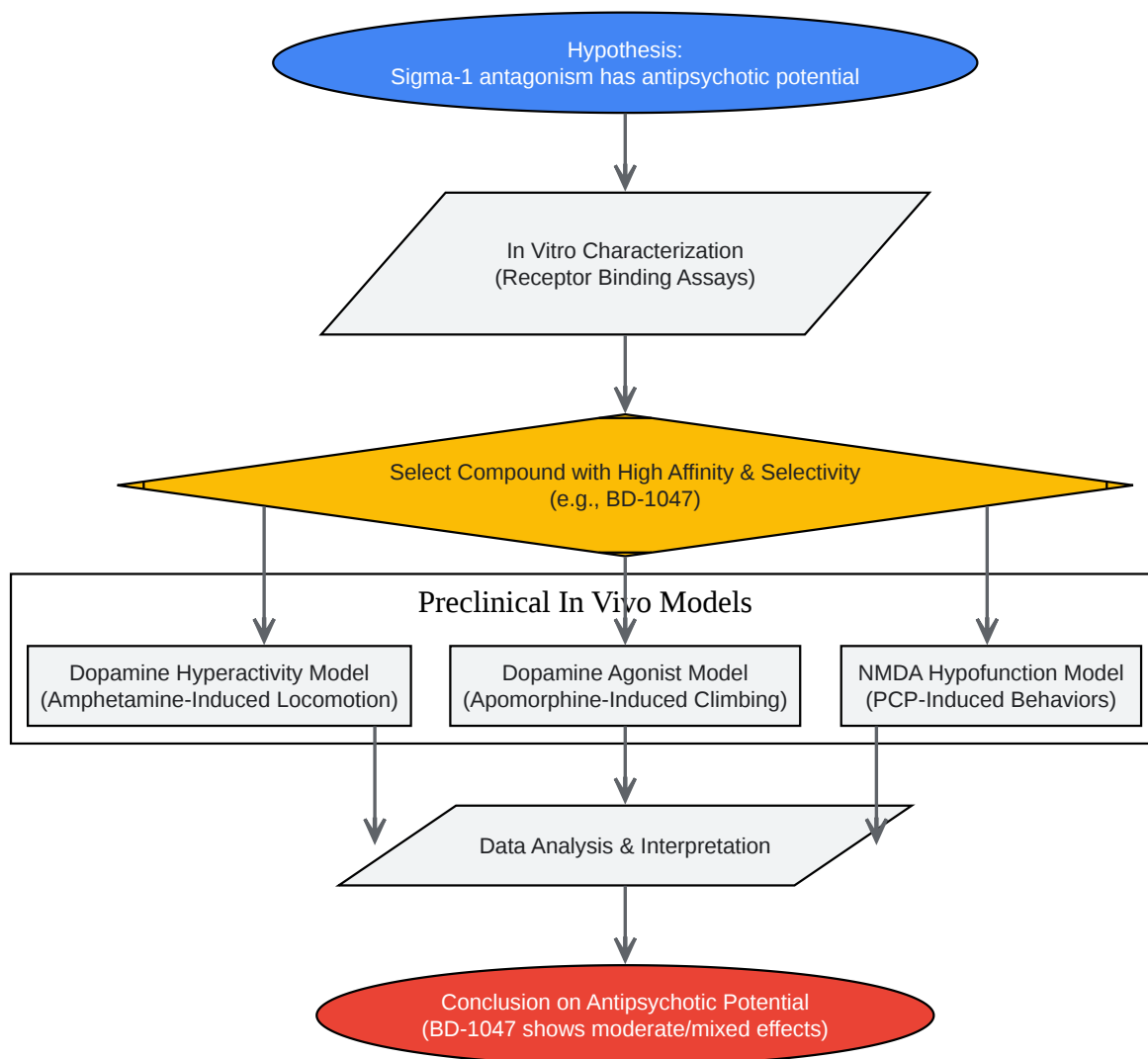

[Click to download full resolution via product page](#)

Caption: Preclinical workflow for evaluating antipsychotic potential.

Conclusion

The preclinical data for **BD-1047** suggest a nuanced and complex profile. Its high affinity and selectivity for the sigma-1 receptor are well-established. However, its efficacy in animal models predictive of antipsychotic activity is moderate and inconsistent. While **BD-1047** shows activity in models related to dopamine agonism (apomorphine-induced climbing) and glutamate

antagonism (PCP-induced behaviors), its lack of efficacy in the amphetamine-induced hyperactivity model raises questions about its potential as a broad-spectrum antipsychotic.[1] [2] These mixed results suggest that while sigma-1 receptor antagonism may influence pathways relevant to psychosis, its utility as a standalone antipsychotic therapy may be limited. [1] Further research, particularly studies employing a wider range of doses and exploring effects on negative and cognitive symptoms, would be necessary to fully elucidate the therapeutic potential of **BD-1047**.

Need Custom Synthesis?

BenchChem offers custom synthesis for rare earth carbides and specific isotopic labeling.

Email: info@benchchem.com or [Request Quote Online](#).

References

- [1. Effect of BD 1047, a sigma1 receptor antagonist, in the animal models predictive of antipsychotic activity - PubMed \[pubmed.ncbi.nlm.nih.gov\]](#)
- [2. researchgate.net \[researchgate.net\]](#)
- [3. medchemexpress.com \[medchemexpress.com\]](#)
- [4. medchemexpress.com \[medchemexpress.com\]](#)
- To cite this document: BenchChem. [Exploring the Antipsychotic Potential of BD-1047: A Technical Guide]. BenchChem, [2026]. [Online PDF]. Available at: [\[https://www.benchchem.com/product/b1210693/docs#exploring-the-antipsychotic-potential-of-bd-1047-a-technical-guide\]](https://www.benchchem.com/product/b1210693/docs#exploring-the-antipsychotic-potential-of-bd-1047-a-technical-guide)

Disclaimer & Data Validity:

The information provided in this document is for Research Use Only (RUO) and is strictly not intended for diagnostic or therapeutic procedures. While BenchChem strives to provide accurate protocols, we make no warranties, express or implied, regarding the fitness of this product for every specific experimental setup.

Technical Support: The protocols provided are for reference purposes. Unsure if this reagent suits your experiment?

Need Industrial/Bulk Grade? [Request Custom Synthesis Quote](#)

BenchChem

Our mission is to be the trusted global source of essential and advanced chemicals, empowering scientists and researchers to drive progress in science and industry.

Contact

Address: 3281 E Guasti Rd
Ontario, CA 91761, United States
Phone: (601) 213-4426
Email: info@benchchem.com

[Contact our Ph.D. Support Team for a compatibility check](#)