

Best practices for long-term administration of U-54494A

Author: BenchChem Technical Support Team. **Date:** April 2026

Compound of Interest

Compound Name:	U-54494A
CAS No.:	92953-41-8
Cat. No.:	B1210402

[Get Quote](#)

Technical Support Center: U-54494A Administration

This technical support center provides guidance on the best practices for the long-term administration of **U-54494A** in a research setting. The information is intended for researchers, scientists, and drug development professionals.

Troubleshooting Guide

Issue	Potential Cause	Recommended Action
<p>Reduced Anticonvulsant Efficacy Over Time</p>	<p>Development of tolerance to the anticonvulsant effects of U-54494A, a known phenomenon with some kappa opioid agonists.</p>	<ul style="list-style-type: none"> - Consider a gradual dose escalation to counteract tolerance. - Implement intermittent dosing schedules (e.g., drug-free periods) to potentially restore sensitivity. - Evaluate for changes in the expression or sensitivity of kappa opioid receptors in your animal model.
<p>Observed Sedation or Motor Impairment</p>	<p>Off-target effects or excessive dosage. While U-54494A is reported to have a better therapeutic index than other kappa opioid agonists, these effects can still occur, particularly at higher doses.^[1]</p>	<ul style="list-style-type: none"> - Perform a dose-response study to identify the minimal effective dose with the least sedative effects. - Utilize motor function tests (e.g., rotarod) to quantify the extent of impairment at different doses. [1] - Consider alternative routes of administration that may alter the pharmacokinetic and side-effect profile.
<p>Precipitation of U-54494A in Solution</p>	<p>Poor solubility in the chosen vehicle.</p>	<ul style="list-style-type: none"> - Prepare stock solutions in a suitable organic solvent such as DMSO before diluting to the final concentration with an aqueous vehicle like saline. - Ensure the final concentration of the organic solvent is within the acceptable limits for your animal model to avoid vehicle-induced toxicity. - Prepare fresh solutions for each experiment to minimize the risk of precipitation over time.

Inconsistent Anticonvulsant Effects Between Animals	Variability in drug metabolism and the production of active metabolites. U-54494A is metabolized into active compounds, and individual differences in metabolic rates can lead to varied responses. [2]	- Ensure a consistent genetic background of the animals used in the study. - Increase the sample size to account for individual variability. - Monitor plasma levels of U-54494A and its major metabolites if possible to correlate with efficacy.
Signs of Distress or Aversive Behavior in Animals	Potential for dysphoric effects, a known side effect of some kappa opioid agonists.	- Carefully observe animals for behavioral changes (e.g., altered vocalizations, changes in grooming, avoidance behaviors). - Consider incorporating behavioral assays that can assess mood and affect, such as conditioned place preference or aversion tests.

Frequently Asked Questions (FAQs)

Q1: What is the recommended starting dose for long-term anticonvulsant studies with **U-54494A**?

A1: Based on acute studies, an effective dose (ED50) for the maximal electroshock seizure test in mice is approximately 28 mg/kg i.p.[3] For long-term studies, it is advisable to start with a dose in this range and adjust based on efficacy and observed side effects. A pilot study to determine the optimal dose for chronic administration in your specific seizure model and animal species is highly recommended.

Q2: How should **U-54494A** be prepared for in vivo administration?

A2: **U-54494A** is typically available as a hydrochloride salt. For intraperitoneal (i.p.) injections, it can be dissolved in sterile saline. If solubility is an issue, a stock solution can be prepared in a small amount of dimethyl sulfoxide (DMSO) and then diluted with saline to the final desired

concentration. Ensure the final DMSO concentration is low (typically <5%) to avoid vehicle-induced toxicity.

Q3: What is the expected duration of action of **U-54494A**?

A3: **U-54494A** is described as a long-acting anticonvulsant.[2] This is, in part, due to its conversion to active metabolites.[2] The precise duration of action in a long-term dosing paradigm may vary, so it is important to determine the optimal dosing interval for your experimental design through pharmacokinetic and pharmacodynamic studies.

Q4: Can tolerance develop to the anticonvulsant effects of **U-54494A**?

A4: While specific long-term studies on tolerance to **U-54494A**'s anticonvulsant effects are not readily available, tolerance is a known phenomenon with repeated administration of other kappa opioid agonists. Researchers should be vigilant for any decrease in efficacy over time and may need to adjust the dosing regimen accordingly.

Q5: What are the potential side effects to monitor during long-term administration of **U-54494A**?

A5: Although **U-54494A** is reported to have fewer sedative and analgesic effects compared to other kappa opioid agonists, it is still crucial to monitor for potential side effects.[1][2] These may include sedation, motor impairment, and potential dysphoria. Regular monitoring of the animals' general health, body weight, and behavior is essential.[4]

Quantitative Data

Table 1: Solubility of **U-54494A**

Solvent	Solubility	Notes
Water	Sparingly soluble	Solubility is pH-dependent.
Saline (0.9% NaCl)	Soluble with sonication	Suitable for in vivo injections at appropriate concentrations.
DMSO (Dimethyl Sulfoxide)	Highly soluble	Can be used to prepare concentrated stock solutions.
Ethanol	Soluble	Can be used as a co-solvent.

Table 2: In Vivo Efficacy of **U-54494A** in Animal Models of Seizure

Animal Model	Seizure Type	Effective Dose (ED50)	Route of Administration	Reference
Mice	Maximal Electroshock Seizure	28 mg/kg	Intraperitoneal (i.p.)	[3]
Rats (genetically epilepsy-prone)	Audiogenic Seizures	Dose-dependent anticonvulsant activity	Intraperitoneal (i.p.) & Intracerebroventricular (i.c.v.)	[1]
DBA/2 Mice (genetically epilepsy-prone)	Audiogenic Seizures	Dose-dependent anticonvulsant activity	Intraperitoneal (i.p.) & Intracerebroventricular (i.c.v.)	[1]
Rats (chronically implanted electrodes)	Electrically Evoked Hippocampal Afterdischarges	≥ 10 mg/kg	Not specified	[3]

Experimental Protocols

Protocol 1: Assessment of Anticonvulsant Efficacy in a Chronic Seizure Model (e.g., Kindling Model)

- Animal Model: Use a validated chronic seizure model, such as the amygdala kindling model in rats.
- Kindling Procedure: Surgically implant electrodes into the amygdala. Deliver a low-level electrical stimulation daily until a stable, fully kindled state (e.g., Racine stage 5 seizures) is achieved.
- Drug Administration:
 - Prepare **U-54494A** in a sterile vehicle (e.g., saline with a minimal amount of DMSO if needed).
 - Administer **U-54494A** intraperitoneally at the predetermined dose and time interval. A control group should receive the vehicle only.
- Seizure Monitoring:
 - After drug administration, stimulate the animals at their individual afterdischarge threshold.
 - Record and score the behavioral seizure severity using the Racine scale.
 - Measure the afterdischarge duration from the electroencephalogram (EEG) recordings.
- Long-Term Monitoring: Continue the daily drug administration and seizure testing for the duration of the study. Monitor for any changes in seizure threshold, seizure severity, and afterdischarge duration.
- Data Analysis: Compare the seizure parameters between the **U-54494A**-treated group and the vehicle-treated control group over time using appropriate statistical methods.

Visualizations

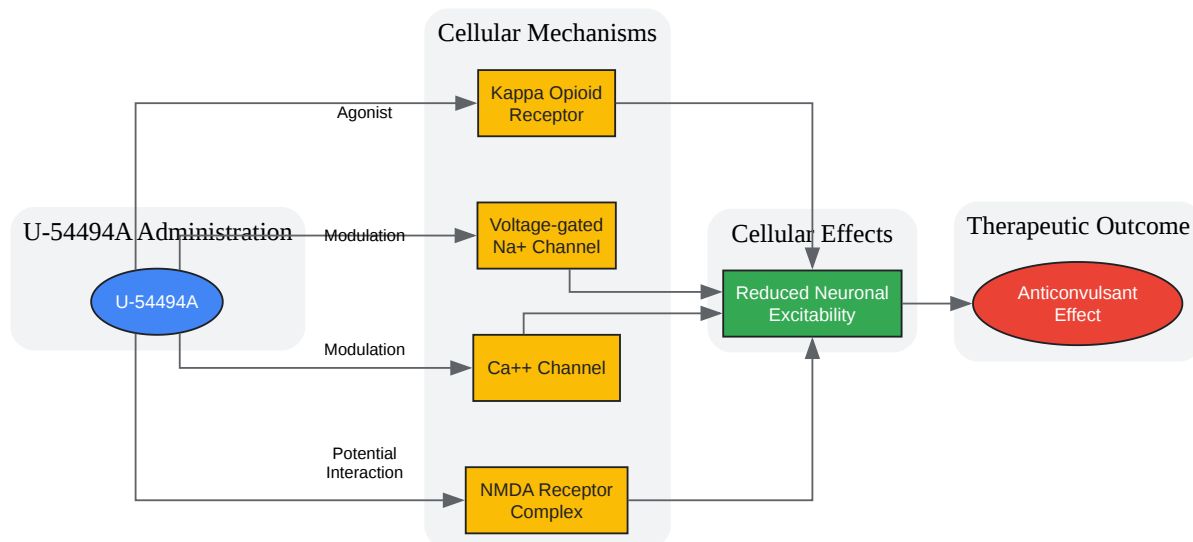

[Click to download full resolution via product page](#)

Caption: Simplified signaling pathway of **U-54494A**.

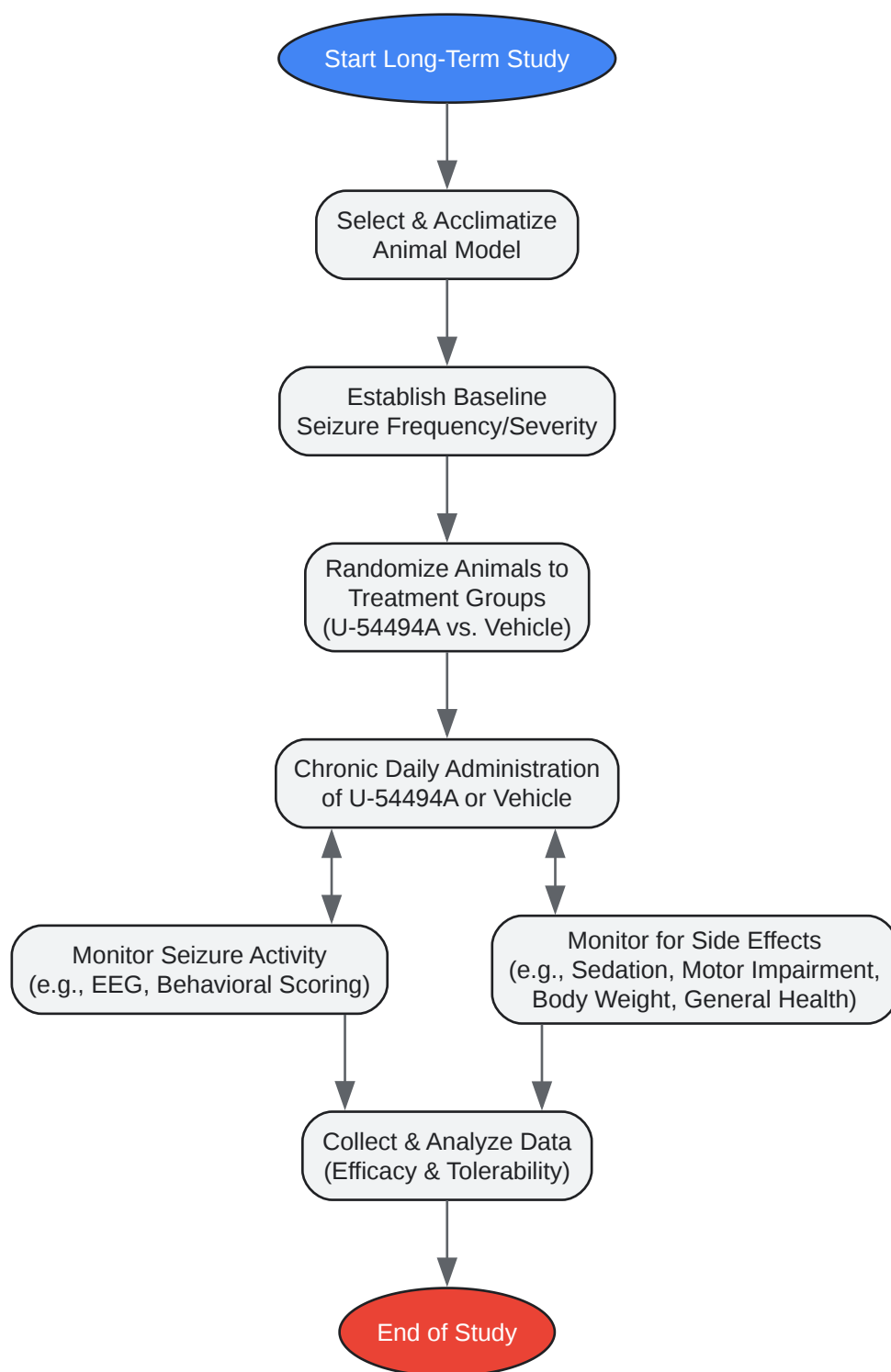

[Click to download full resolution via product page](#)

Caption: General experimental workflow for long-term **U-54494A** administration.

Need Custom Synthesis?

BenchChem offers custom synthesis for rare earth carbides and specific isotopic labeling.

Email: info@benchchem.com or [Request Quote Online](#).

References

- 1. Anticonvulsant effects of U-54494A and U-50488H in genetically epilepsy-prone rats and DBA/2 mice: a possible involvement of glycine/NMDA receptor complex - PubMed [pubmed.ncbi.nlm.nih.gov]
- 2. Two metabolites of anticonvulsant U-54494A: their anticonvulsant activity and interaction with sodium channel - PubMed [pubmed.ncbi.nlm.nih.gov]
- 3. Anticonvulsant and related effects of U-54494A in various seizure tests - PubMed [pubmed.ncbi.nlm.nih.gov]
- 4. Long-term toxicity study of carmoisine in rats using animals exposed in utero - PubMed [pubmed.ncbi.nlm.nih.gov]
- To cite this document: BenchChem. [Best practices for long-term administration of U-54494A]. BenchChem, [2026]. [Online PDF]. Available at: [<https://www.benchchem.com/product/b1210402/docs#best-practices-for-long-term-administration-of-u-54494a>]

Disclaimer & Data Validity:

The information provided in this document is for Research Use Only (RUO) and is strictly not intended for diagnostic or therapeutic procedures. While BenchChem strives to provide accurate protocols, we make no warranties, express or implied, regarding the fitness of this product for every specific experimental setup.

Technical Support: The protocols provided are for reference purposes. Unsure if this reagent suits your experiment?

Need Industrial/Bulk Grade? [Request Custom Synthesis Quote](#)

BenchChem

Our mission is to be the trusted global source of essential and advanced chemicals, empowering scientists and researchers to drive progress in science and industry.

Contact

Address: 3281 E Guasti Rd

Ontario, CA 91761, United States

Phone: (601) 213-4426

Email: info@benchchem.com

[Contact our Ph.D. Support Team for a compatibility check](#)