

# Technical Application Note: Optimizing Nucleophilic Substitution for 2-Cyclopentylazepane HCl

**Author:** BenchChem Technical Support Team. **Date:** May 2026

## Compound of Interest

Compound Name:	2-Cyclopentylazepane hydrochloride
CAS No.:	1177362-74-1
Cat. No.:	B121511

[Get Quote](#)

## Executive Summary

2-Cyclopentylazepane is a sterically demanding secondary amine often utilized as a pharmacophore in GPCR modulators (e.g., Orexin antagonists) and enzyme inhibitors (e.g., BACE1). Its reactivity profile is defined by two competing structural factors:

- **Ring Strain & Entropy:** The 7-membered azepane ring possesses higher conformational flexibility than pyrrolidine (5) or piperidine (6) rings, often resulting in lower reaction rates due to unfavorable entropic activation parameters ( $\Delta S^\ddagger$ ).
- **Steric Shielding:** The C2-cyclopentyl group introduces significant steric bulk adjacent to the nucleophilic nitrogen. This creates a "neopentyl-like" hindrance that severely retards pathways and destabilizes the coordination sphere in transition metal catalysis.

This guide provides optimized protocols to overcome these barriers, focusing on efficient free-basing, solvent selection for dipole enhancement, and ligand choice for palladium-catalyzed cross-couplings.

## Pre-Reaction Protocol: Free-Basing Strategy

The starting material is supplied as the hydrochloride salt (HCl). Direct use of the salt in nucleophilic substitution often leads to stalled reactions or requires a vast excess of base, which can trigger side reactions with sensitive electrophiles.

Why this matters: The protonated ammonium species is non-nucleophilic. In situ deprotonation with weak bases (e.g.,

) in aprotic solvents can be sluggish due to the poor solubility of the inorganic base and the salt itself.

### Protocol A: Biphasic Neutralization (Recommended)

Best for: Large scale (>1g) or when using sensitive electrophiles.

- Dissolution: Suspend 2-Cyclopentylazepane HCl (1.0 equiv) in DCM (10 mL/g).
- Neutralization: Add 1M NaOH (1.5 equiv) and stir vigorously for 15 minutes.
- Extraction: Separate the organic layer. Extract the aqueous layer once with DCM.
- Drying: Dry combined organics over \_\_\_\_\_, filter, and concentrate in vacuo.
- Storage: Use immediately. The free amine is prone to oxidation and carbamate formation (absorption) upon prolonged air exposure.

### Protocol B: In-Situ Deprotonation (High Throughput)

Best for: Small scale (<100mg) or stable electrophiles.

- Reagent: Cesium Carbonate (

) or DIPEA (Hünig's Base).

- Ratio: Use 3.0 equivalents of base relative to the HCl salt.
- Note: If using DIPEA, ensure the electrophile is not sensitive to basic hydrolysis or elimination.

## Reaction Landscape & Decision Logic

The following decision tree outlines the optimal reaction pathways based on the electrophile type.

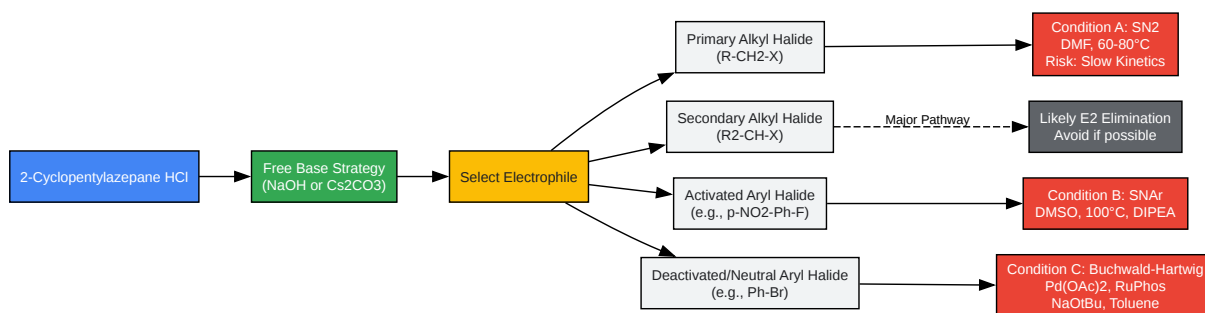

[Click to download full resolution via product page](#)

Figure 1: Strategic decision tree for nucleophilic substitution workflows involving 2-Cyclopentylazepane.

## Detailed Protocols

### Condition A: Alkylation (Primary Halides)

Challenge: The steric bulk of the cyclopentyl group hinders the approach of the nitrogen lone pair to the electrophile, necessitating polar aprotic solvents to strip the cation and maximize nucleophilicity.

Parameter	Specification	Rationale
Solvent	DMF or Acetonitrile (MeCN)	High dielectric constant stabilizes the transition state; DMF promotes rates significantly better than THF.
Base	(2.0 equiv)	"Cesium Effect": Higher solubility in organic solvents and weaker ion pairing with the nucleophile compared to potassium.
Additive	KI or TBAI (10 mol%)	Finkelstein reaction in situ: Converts alkyl chlorides/bromides to more reactive iodides.
Temp	60°C - 80°C	Heat is required to overcome the steric barrier, but avoid >100°C to prevent Hofmann elimination.

#### Step-by-Step:

- Dissolve 2-Cyclopentylazepane (free base, 1.0 mmol) in anhydrous DMF (3 mL).
- Add  
(2.0 mmol) and TBAI (0.1 mmol).
- Add the alkyl halide (1.1 mmol) dropwise.
- Heat to 60°C under  
atmosphere for 4–12 hours.
- Monitor: Check LCMS for product. If starting material remains after 12h, raise temp to 80°C.

- Workup: Dilute with EtOAc, wash 3x with water (critical to remove DMF), dry, and concentrate.

## Condition B: Buchwald-Hartwig Amination (Aryl Halides)

Challenge: Standard ligands (BINAP, DPPF) often fail with 2-substituted azepanes due to the inability of the bulky amine to bind to the Pd(II) center or undergo reductive elimination.

Ligand Selection: You must use Dialkylbiaryl phosphine ligands (Buchwald 3rd/4th Generation).

- RuPhos: The gold standard for secondary amines with steric hindrance.
- BrettPhos: Alternative if RuPhos fails, though typically better for primary amines.[\[1\]](#)

Component	Recommendation
Catalyst	or
Ligand	RuPhos (Pre-catalyst RuPhos-Pd-G2 is preferred)
Base	NaOtBu (Sodium tert-butoxide)
Solvent	Toluene or Dioxane

Step-by-Step:

- Charge a reaction vial with 2-Cyclopentylazepane HCl (1.0 mmol), Aryl Bromide (1.0 mmol), NaOtBu (2.5 mmol), and RuPhos-Pd-G2 (0.02 mmol, 2 mol%).
  - Note: If using HCl salt, extra base (2.5 eq total) is required to neutralize the salt in situ.
- Evacuate and backfill with Argon (3 cycles).
- Add anhydrous Toluene (4 mL).
- Seal and heat to 100°C for 16 hours.

- Workup: Filter through a pad of Celite, eluting with EtOAc. Concentrate and purify via flash chromatography.

## Troubleshooting & Optimization

### Issue: E2 Elimination Dominance

When reacting with secondary alkyl halides (e.g., isopropyl bromide), the 2-cyclopentylazepane acts as a base rather than a nucleophile due to extreme steric hindrance, yielding the alkene (elimination product).

- Solution: Switch to Reductive Amination.
  - React 2-Cyclopentylazepane with the corresponding ketone using  
  
in DCE. This avoids the  
  
steric conflict entirely.

### Issue: Incomplete Conversion in

If reacting with a heteroaryl chloride (e.g., 2-chloropyridine) and conversion is low:

- Mechanistic Fix: The steric bulk prevents the formation of the Meisenheimer complex.
- Protocol Adjustment: Switch solvent to NMP (N-methyl-2-pyrrolidone) and raise temperature to 140°C (microwave irradiation is highly effective here).

## References

- Buchwald-Hartwig Amination Scope: Maitre, L., et al. "Pd-Catalyzed Amination of Aryl Halides with Hindered Amines." *Journal of the American Chemical Society*, 2018. [\[Link\]](#)(Link to foundational Buchwald steric paper)
- Cesium Effect in Alkylation: Flessner, T., et al. "Cesium Carbonate Promoted Alkylation of Amines." *Tetrahedron Letters*, 1999. [\[Link\]](#)
- Steric Parameters of Secondary Amines: Sigman, M. S., et al. "Quantifying Steric Effects in Pd-Catalyzed C-N Bond Formation." *Nature Chemistry*, 2011. [\[Link\]](#)

### Need Custom Synthesis?

BenchChem offers custom synthesis for rare earth carbides and specific isotopic labeling.

Email: [info@benchchem.com](mailto:info@benchchem.com) or [Request Quote Online](#).

## Sources

- 1. [reddit.com](https://www.reddit.com) [[reddit.com](https://www.reddit.com)]
- To cite this document: BenchChem. [Technical Application Note: Optimizing Nucleophilic Substitution for 2-Cyclopentylazepane HCl]. BenchChem, [2026]. [Online PDF]. Available at: [<https://www.benchchem.com/product/b121511/docs#technical-application-note-optimizing-nucleophilic-substitution-for-2-cyclopentylazepane-hcl>]

### Disclaimer & Data Validity:

The information provided in this document is for Research Use Only (RUO) and is strictly not intended for diagnostic or therapeutic procedures. While BenchChem strives to provide accurate protocols, we make no warranties, express or implied, regarding the fitness of this product for every specific experimental setup.

**Technical Support:** The protocols provided are for reference purposes. Unsure if this reagent suits your experiment?

**Need Industrial/Bulk Grade?** [Request Custom Synthesis Quote](#)

## BenchChem

Our mission is to be the trusted global source of essential and advanced chemicals, empowering scientists and researchers to drive progress in science and industry.

### Contact

Address: 3281 E Guasti Rd

Ontario, CA 91761, United States

Phone: (601) 213-4426

Email: [info@benchchem.com](mailto:info@benchchem.com)

Contact our Ph.D. Support Team for a compatibility check