

Application Notes and Protocols for Assessing the Genotoxicity of Asomate

Author: BenchChem Technical Support Team. **Date:** April 2026

Compound of Interest

Compound Name:	Asomate
CAS No.:	3586-60-5
Cat. No.:	B121781

[Get Quote](#)

For Researchers, Scientists, and Drug Development Professionals

Introduction

The assessment of genotoxicity is a critical component in the safety evaluation of any new chemical entity (NCE), such as **Asomate**. Genotoxicity refers to the property of chemical agents to damage the genetic information within a cell, causing mutations which may lead to cancer.[1] A comprehensive evaluation of a compound's genotoxic potential is required by regulatory agencies worldwide to ensure human safety.[2][3]

This document provides detailed application notes and standardized protocols for a tiered approach to assessing the genotoxicity of **Asomate**. The recommended testing strategy aligns with international guidelines, such as those from the Organisation for Economic Co-operation and Development (OECD) and the International Council for Harmonisation (ICH).[2][4] The core principle is a battery of in vitro and in vivo tests designed to detect the three main endpoints of genetic damage: gene mutation, clastogenicity (structural chromosomal aberration), and aneugenicity (numerical chromosomal aberration).[5]

Tier 1: In Vitro Genotoxicity Testing Battery

The initial stage of testing involves a battery of in vitro assays to identify any potential genotoxic hazards.[5] This battery is designed to be highly sensitive and to cover a broad range of genotoxic mechanisms.

Bacterial Reverse Mutation Test (Ames Test)

The Ames test is a widely used method for detecting gene mutations, specifically point mutations, induced by a chemical.[4][5] It utilizes several strains of *Salmonella typhimurium* and *Escherichia coli* with pre-existing mutations that render them unable to synthesize an essential amino acid (e.g., histidine or tryptophan). The assay determines if **Asomate** can cause a reverse mutation, allowing the bacteria to grow on an amino acid-deficient medium.

Experimental Protocol: Ames Test (OECD TG 471)

Materials:

- *Salmonella typhimurium* strains (e.g., TA98, TA100, TA1535, TA1537)
- *Escherichia coli* strains (e.g., WP2 uvrA)
- **Asomate** (test substance) dissolved in a suitable solvent
- Positive controls (e.g., sodium azide, 2-nitrofluorene, 4-nitroquinoline-N-oxide, benzo[a]pyrene)
- Negative/vehicle control
- S9 metabolic activation system (post-mitochondrial fraction of liver homogenate from induced rodents)[6][7]
- Cofactors for S9 mix (e.g., NADP, G6P)
- Minimal glucose agar plates
- Top agar

Procedure:

- Preparation: Prepare fresh cultures of the bacterial strains overnight. Prepare the S9 mix on the day of the experiment. Prepare serial dilutions of **Asomate**.
- Treatment (Plate Incorporation Method):
 - To 2 mL of molten top agar, add 0.1 mL of the bacterial culture, 0.1 mL of the **Asomate** solution (or control), and 0.5 mL of the S9 mix (for metabolic activation) or buffer (without S9).
 - Vortex briefly and pour the mixture onto minimal glucose agar plates.
- Incubation: Incubate the plates at 37°C for 48-72 hours.
- Scoring: Count the number of revertant colonies on each plate. A positive result is indicated by a dose-dependent increase in the number of revertant colonies that is at least twice the background count.

Data Presentation:

Asomate Concentration	Strain	S9 Activation	Mean Revertant Colonies ± SD	Fold Increase over Control
Vehicle Control	TA100	-	25 ± 5	1.0
Asomate (μg/plate)	TA100	-		
Asomate (μg/plate)	TA100	-		
Asomate (μg/plate)	TA100	-		
Positive Control	TA100	-	250 ± 20	10.0
Vehicle Control	TA100	+	30 ± 6	1.0
Asomate (μg/plate)	TA100	+		
Asomate (μg/plate)	TA100	+		
Asomate (μg/plate)	TA100	+		
Positive Control	TA100	+	300 ± 25	10.0

(This table should be populated for each bacterial strain used)

Experimental Workflow for the Ames Test

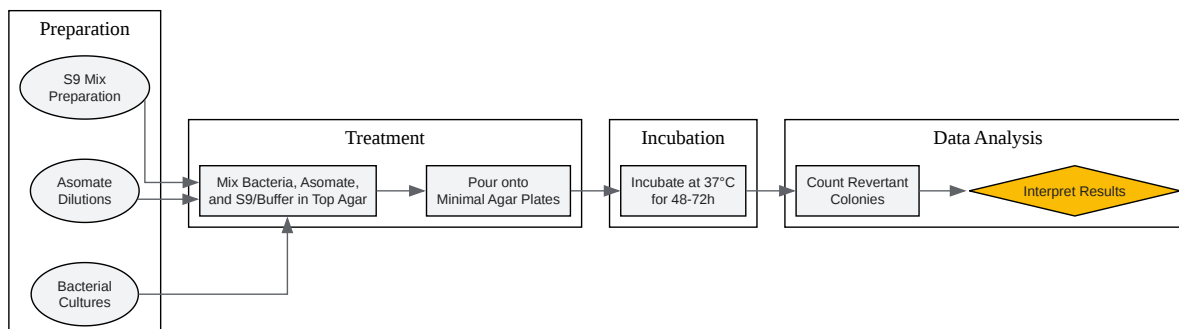

[Click to download full resolution via product page](#)

Caption: Workflow for the Bacterial Reverse Mutation (Ames) Test.

In Vitro Micronucleus Test

The in vitro micronucleus test detects chromosomal damage.[4] Micronuclei are small, extranuclear bodies that are formed from chromosome fragments or whole chromosomes that lag behind during cell division. An increase in the frequency of micronucleated cells indicates clastogenic or aneugenic activity.

Experimental Protocol: In Vitro Micronucleus Test (OECD TG 487)

Materials:

- Mammalian cell line (e.g., CHO, V79, L5178Y, TK6, or human peripheral blood lymphocytes)
- **Asomate** dissolved in a suitable solvent
- Positive controls (e.g., mitomycin C, colchicine)
- Negative/vehicle control

- S9 metabolic activation system
- Cytochalasin B (to block cytokinesis, resulting in binucleated cells)
- Culture medium, serum, and antibiotics
- Fixative (e.g., methanol/acetic acid)
- Staining solution (e.g., Giemsa, DAPI)
- Microscope slides

Procedure:

- Cell Culture: Culture cells to an appropriate density.
- Treatment: Expose the cells to various concentrations of **Asomate**, with and without S9 metabolic activation, for a short period (e.g., 3-6 hours). Also include positive and negative controls.
- Recovery: After exposure, wash the cells and incubate them in fresh medium. Add cytochalasin B to block cytokinesis. The total culture time should be approximately 1.5-2 normal cell cycles.
- Harvesting and Staining: Harvest the cells, subject them to hypotonic treatment, fix them, and drop them onto microscope slides. Stain the slides with a DNA-specific stain.
- Scoring: Score at least 2000 binucleated cells per concentration for the presence of micronuclei. The Cytokinesis-Block Proliferation Index (CBPI) should also be calculated to assess cytotoxicity.

Data Presentation:

Asomate Concentration (µM)	S9 Activation	No. of Binucleated Cells Scored	No. of Micronucleated Binucleated Cells	% Micronucleated Cells	CBPI
Vehicle Control	-	2000	10	0.5	1.9
Asomate	-	2000			
Asomate	-	2000			
Asomate	-	2000			
Positive Control	-	2000	100	5.0	1.5
Vehicle Control	+	2000	12	0.6	1.8
Asomate	+	2000			
Asomate	+	2000			
Asomate	+	2000			
Positive Control	+	2000	120	6.0	1.4

Experimental Workflow for the In Vitro Micronucleus Test

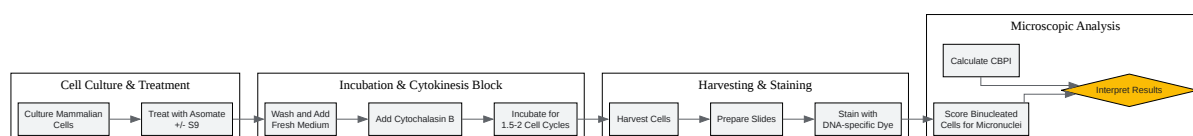

[Click to download full resolution via product page](#)

Caption: Workflow for the In Vitro Micronucleus Test.

Tier 2: In Vivo Genotoxicity Testing

If **Asomate** shows positive results in the in vitro battery, in vivo testing is necessary to determine if the genotoxic effects are expressed in a whole animal system.[8] In vivo assays account for the absorption, distribution, metabolism, and excretion (ADME) of the test substance.

In Vivo Mammalian Erythrocyte Micronucleus Test

This assay is the in vivo counterpart to the in vitro micronucleus test and is the most widely used in vivo genotoxicity assay. It assesses chromosomal damage in the bone marrow of rodents.

Experimental Protocol: In Vivo Micronucleus Test (OECD TG 474)

Materials:

- Rodents (mice or rats)
- **Asomate**
- Positive controls (e.g., cyclophosphamide)
- Negative/vehicle control
- Fetal bovine serum
- Acridine orange or other suitable stain
- Microscope slides

Procedure:

- Dosing: Administer **Asomate** to the animals, typically via the clinical route of administration, at multiple dose levels. A common dosing regimen is two administrations 24 hours apart.

- **Sample Collection:** Collect bone marrow from the femur or tibia at 24 and 48 hours after the final dose.
- **Slide Preparation:** Prepare bone marrow smears on microscope slides.
- **Staining:** Stain the slides to differentiate between polychromatic erythrocytes (PCEs; immature red blood cells) and normochromatic erythrocytes (NCEs; mature red blood cells).
- **Scoring:** Score at least 4000 PCEs per animal for the presence of micronuclei. Also, determine the ratio of PCEs to NCEs to assess bone marrow toxicity.

Data Presentation:

Dose of Asomate (mg/kg)	Animal ID	No. of PCEs Scored	No. of Micronucleated PCEs	% Micronucleated PCEs	PCE/(PCE+NCE) Ratio
Vehicle Control	1	4000	8	0.20	0.55
	2	4000	6	0.15	0.58
...					
Low Dose	1	4000			
	2	4000			
...					
Mid Dose	1	4000			
	2	4000			
...					
High Dose	1	4000			
	2	4000			
...					
Positive Control	1	4000	80	2.00	0.30
	2	4000	88	2.20	0.28
...					

In Vivo Comet Assay (Single Cell Gel Electrophoresis)

The Comet assay is a sensitive method for detecting DNA strand breaks in individual cells.^[9] It can be performed on various tissues from animals treated with a test substance.

Experimental Protocol: In Vivo Comet Assay (OECD TG 489)

Materials:

- Rodents
- **Asomate**
- Positive control (e.g., ethyl methanesulfonate)
- Negative/vehicle control
- Minced tissue (e.g., liver, stomach)
- Lysis solution
- Electrophoresis buffer
- DNA stain (e.g., SYBR Green, propidium iodide)
- Microscope slides pre-coated with agarose
- Fluorescence microscope with appropriate software

Procedure:

- Dosing: Administer **Asomate** to animals as in the micronucleus test.
- Tissue Collection: Collect target tissues at an appropriate time after dosing (typically 2-6 hours).
- Cell Isolation and Lysis: Prepare a single-cell suspension from the tissue, embed the cells in agarose on a microscope slide, and lyse the cells with a high-salt and detergent solution to remove membranes and proteins, leaving behind the DNA as a nucleoid.
- Electrophoresis: Place the slides in an electrophoresis chamber with alkaline or neutral buffer. The electric field will pull the broken DNA fragments away from the nucleoid, forming a "comet tail."
- Staining and Scoring: Stain the DNA and visualize it using a fluorescence microscope. Quantify the amount of DNA in the comet tail using image analysis software. Common metrics include % tail DNA, tail length, and tail moment.

Data Presentation:

Dose of Asomate (mg/kg)	Tissue	Animal ID	Mean % Tail DNA ± SD
Vehicle Control	Liver	1	2.5 ± 1.0
2	2.8 ± 1.2		
...			
Low Dose	Liver	1	
2			
...			
Mid Dose	Liver	1	
2			
...			
High Dose	Liver	1	
2			
...			
Positive Control	Liver	1	25.0 ± 5.0
2	28.0 ± 6.0		
...			

(This table should be populated for each tissue analyzed)

DNA Damage Response Signaling Pathway

Genotoxic agents like **Asomate**, if they induce DNA damage, can activate complex cellular signaling pathways to arrest the cell cycle and initiate DNA repair or apoptosis. A key pathway involves the activation of ATM (Ataxia-Telangiectasia Mutated) and ATR (ATM and Rad3-related) kinases in response to DNA double-strand and single-strand breaks, respectively.

DNA Damage Response Pathway

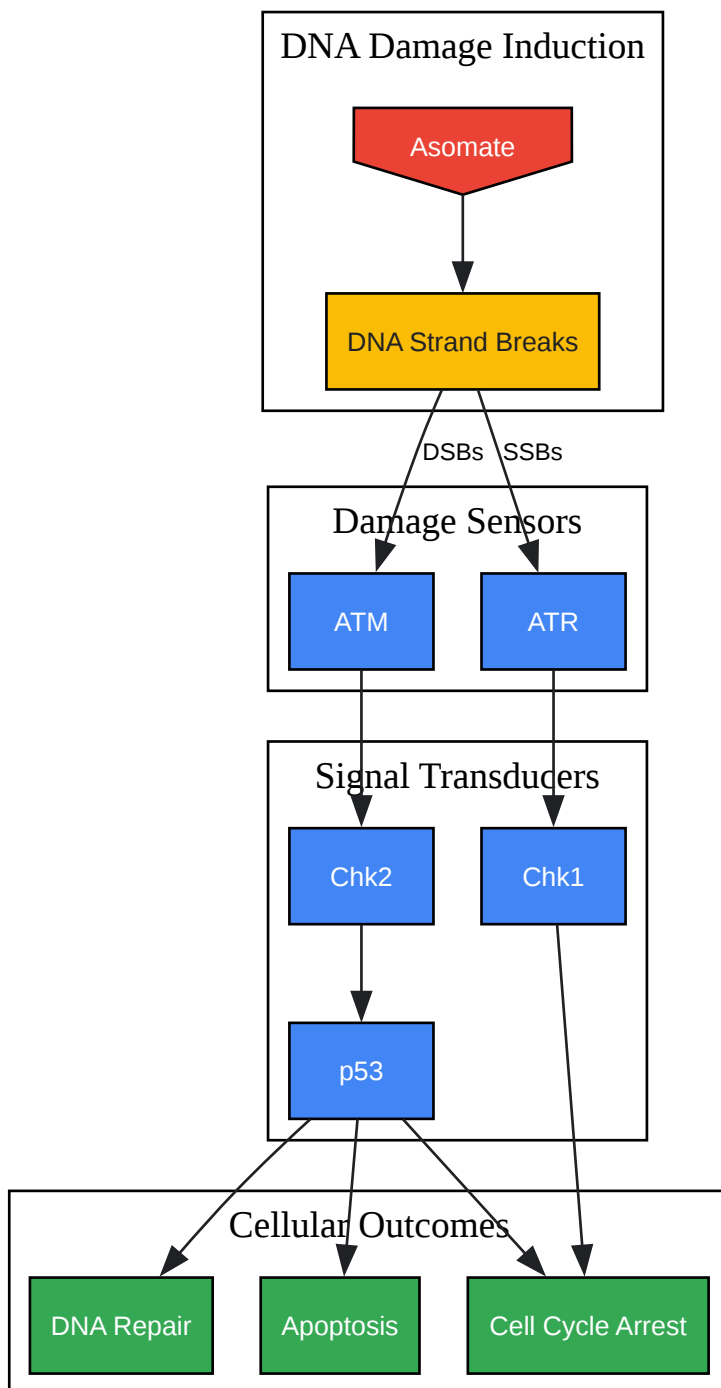

[Click to download full resolution via product page](#)

Caption: A simplified DNA damage response signaling pathway.

Conclusion

The tiered approach outlined in these application notes provides a robust framework for assessing the genotoxic potential of **Asomate**. A negative result in a well-conducted battery of in vitro and in vivo assays provides a high level of confidence in the genotoxic safety of the compound. Positive findings in any of these assays would necessitate further investigation into the mechanism of genotoxicity and a comprehensive risk assessment.

Need Custom Synthesis?

BenchChem offers custom synthesis for rare earth carbides and specific isotopic labeling.

Email: info@benchchem.com or [Request Quote Online](#).

References

- [1. Genotoxicity - Wikipedia \[en.wikipedia.org\]](#)
- [2. fda.gov \[fda.gov\]](#)
- [3. who.int \[who.int\]](#)
- [4. gov.uk \[gov.uk\]](#)
- [5. assets.publishing.service.gov.uk \[assets.publishing.service.gov.uk\]](#)
- [6. An Enhanced Metabolization Protocol for In Vitro Genotoxicity Assessment of N-Nitrosamines in Mammalian Cells - PMC \[pmc.ncbi.nlm.nih.gov\]](#)
- [7. Common Considerations for Genotoxicity Assessment of Nanomaterials - PMC \[pmc.ncbi.nlm.nih.gov\]](#)
- [8. assets.publishing.service.gov.uk \[assets.publishing.service.gov.uk\]](#)
- [9. criver.com \[criver.com\]](#)
- To cite this document: BenchChem. [Application Notes and Protocols for Assessing the Genotoxicity of Asomate]. BenchChem, [2026]. [Online PDF]. Available at: [\[https://www.benchchem.com/product/b121781/docs#application-notes-and-protocols-for-assessing-the-genotoxicity-of-asomate\]](https://www.benchchem.com/product/b121781/docs#application-notes-and-protocols-for-assessing-the-genotoxicity-of-asomate)

Disclaimer & Data Validity:

The information provided in this document is for Research Use Only (RUO) and is strictly not intended for diagnostic or therapeutic procedures. While BenchChem strives to provide accurate protocols, we make no warranties, express or implied, regarding the fitness of this product for every specific experimental setup.

Technical Support: The protocols provided are for reference purposes. Unsure if this reagent suits your experiment?

Need Industrial/Bulk Grade? [Request Custom Synthesis Quote](#)

BenchChem

Our mission is to be the trusted global source of essential and advanced chemicals, empowering scientists and researchers to drive progress in science and industry.

Contact

Address: 3281 E Guasti Rd
Ontario, CA 91761, United States
Phone: (601) 213-4426
Email: info@benchchem.com

[Contact our Ph.D. Support Team for a compatibility check](#)