

Application Notes & Protocols: A Guide to the Experimental Evaluation of Antifolate Activity

Author: BenchChem Technical Support Team. **Date:** May 2026

Compound of Interest

Compound Name: 4-((2,4-Diaminopyrimidin-5-yl)methyl)-2,6-dimethoxyphenol

CAS No.: 21253-58-7

Cat. No.: B121800

[Get Quote](#)

Introduction: The Critical Role of Folate Metabolism and its Inhibition

Antifolates are a cornerstone class of antimetabolite drugs that function by interfering with the metabolic pathways of folic acid (vitamin B9).[1][2] Folic acid is not biologically active itself; it must be reduced to its active form, tetrahydrofolate (THF), to participate in cellular metabolism. THF and its derivatives, collectively known as folates, are essential cofactors that donate one-carbon units for the synthesis of critical cellular building blocks.[3] These processes include the de novo synthesis of purines (adenine and guanine) and thymidylate, which are indispensable for DNA and RNA synthesis and repair.[1][3]

Because of their central role in nucleotide biosynthesis, the disruption of folate pathways has a profound impact on rapidly proliferating cells, which have a high demand for DNA replication. This vulnerability is exploited in the treatment of cancer and various infectious diseases caused by bacteria, protozoa, and fungi.[1][4][5] The primary enzymatic targets for most antifolate drugs are Dihydrofolate Reductase (DHFR) and, in some cases, Thymidylate Synthase (TS).[1][6] DHFR is a crucial enzyme responsible for regenerating the active THF pool from

dihydrofolate (DHF).^{[4][7]} Inhibition of DHFR leads to a depletion of intracellular THF, stalling DNA synthesis and triggering cell cycle arrest and apoptosis, a phenomenon often described as "thymineless death".^{[4][8]}

This technical guide provides a comprehensive overview of the principal experimental protocols used to identify and characterize the activity of novel antifolate compounds. We will delve into both direct enzymatic assays that measure inhibitor-target engagement and cell-based assays that assess the compound's efficacy in a biological context, accounting for critical factors such as cell permeability and potential resistance mechanisms.^[9]

The Folate Metabolic Pathway: A Map of Antifolate Action

To effectively test for antifolate activity, a clear understanding of the target pathway is essential. The diagram below illustrates the central role of DHFR in maintaining the pool of tetrahydrofolate (THF) required for the synthesis of purines and thymidylate—the building blocks of DNA. Antifolates like methotrexate directly inhibit DHFR, breaking the cycle and depleting the THF cofactors necessary for cellular proliferation.

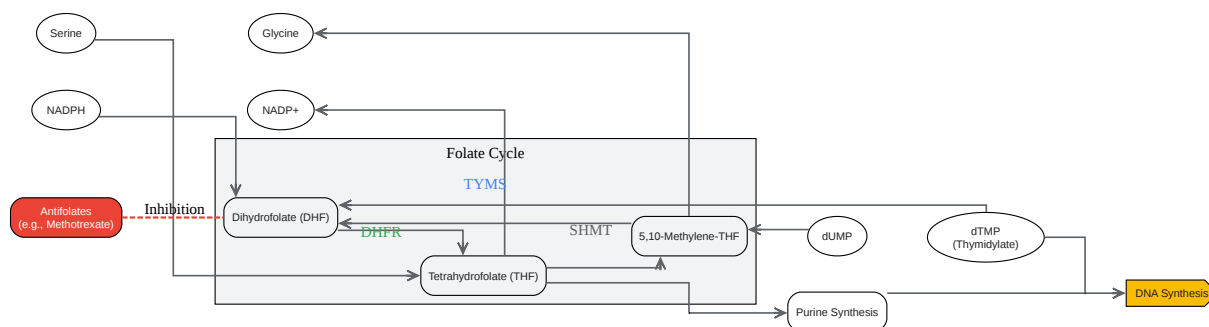

[Click to download full resolution via product page](#)

Caption: The Folate Metabolic Pathway and Point of DHFR Inhibition.

Part 1: Enzymatic Assays for Direct Inhibitor Characterization

The most direct method to confirm that a compound acts as an antifolate is to measure its ability to inhibit the activity of a key enzyme in the pathway. The Dihydrofolate Reductase (DHFR) inhibition assay is the gold-standard biochemical approach for this purpose.

Principle of the DHFR Inhibition Assay

The activity of DHFR is measured by monitoring the oxidation of its cofactor, NADPH, to NADP+.[10] NADPH has a distinct absorbance peak at 340 nm, whereas NADP+ does not. Therefore, the enzymatic activity of DHFR can be quantified by measuring the rate of decrease in absorbance at 340 nm over time.[11] A potent inhibitor of DHFR will slow or halt this decrease. This assay is highly adaptable for high-throughput screening in a 96-well microplate format.[12][13]

Detailed Protocol: Spectrophotometric DHFR Inhibition Assay

This protocol is adapted for a 96-well plate format to screen for DHFR inhibitors.[11]

1. Reagent Preparation:

- DHFR Assay Buffer: 50 mM Potassium Phosphate buffer, pH 7.5, containing 1 mM DTT. Prepare fresh and keep on ice.
- DHFR Enzyme Stock: Reconstitute purified human DHFR enzyme in DHFR Assay Buffer to a stock concentration of 1 U/mL. Aliquot and store at -80°C.
- NADPH Stock (10 mM): Reconstitute NADPH powder in DHFR Assay Buffer. Determine the precise concentration spectrophotometrically (extinction coefficient at 340 nm is 6220 M⁻¹cm⁻¹). Aliquot and store at -20°C, protected from light.[11]

- DHFR Substrate (Dihydrofolate, DHF) Stock (2 mM): Dissolve DHF in DHFR Assay Buffer containing 10 mM 2-mercaptoethanol. DHF is unstable, so prepare this solution fresh on the day of the experiment and protect it from light.
- Test Compound (100X): Dissolve test compounds in 100% DMSO to a concentration 100 times the highest desired final assay concentration.
- Positive Control (Methotrexate, 100X): Prepare a 100-fold dilution series of methotrexate (MTX) in DMSO. MTX is a potent, well-characterized DHFR inhibitor.[\[11\]](#)

2. Assay Procedure in a 96-Well UV-Transparent Plate:

Well Type	Component 1	Component 2	Component 3	Component 4
Test Compound	2 μ L of 100X Test Compound	98 μ L of Diluted DHFR Enzyme	40 μ L of Diluted NADPH	60 μ L of Diluted DHF
Enzyme Control (EC)	2 μ L of DMSO	98 μ L of Diluted DHFR Enzyme	40 μ L of Diluted NADPH	60 μ L of Diluted DHF
Inhibitor Control (IC)	2 μ L of 100X Methotrexate	98 μ L of Diluted DHFR Enzyme	40 μ L of Diluted NADPH	60 μ L of Diluted DHF
Background Control	2 μ L of DMSO	100 μ L of DHFR Assay Buffer	40 μ L of Diluted NADPH	60 μ L of Diluted DHF

Step-by-Step Workflow:

- Prepare Working Solutions: On the day of the experiment, prepare the following dilutions in DHFR Assay Buffer and keep on ice:
 - Diluted DHFR Enzyme: Dilute the DHFR stock to a final working concentration (e.g., 400-fold dilution).[\[14\]](#)
 - Diluted NADPH: Prepare a 40-fold dilution from the 10 mM stock.[\[11\]](#)[\[14\]](#)
 - Diluted DHF Substrate: Prepare a 15-fold dilution from the 2 mM stock.[\[11\]](#)[\[14\]](#)

- Plate Setup: Add 2 μL of the appropriate 100X Test Compound, DMSO (for EC and Background), or Methotrexate (for IC) to the designated wells of a 96-well plate.
- Enzyme Addition: Add 98 μL of the diluted DHFR enzyme to the Test, EC, and IC wells. Add 100 μL of DHFR Assay Buffer to the Background Control wells.
- Pre-incubation: Mix the plate gently and incubate at room temperature for 10-15 minutes to allow inhibitors to bind to the enzyme.
- Cofactor Addition: Add 40 μL of diluted NADPH to all wells. Mix thoroughly.
- Initiate Reaction: The reaction is initiated by adding 60 μL of the diluted DHF substrate to all wells. The total reaction volume should be 200 μL .
- Kinetic Measurement: Immediately place the plate in a microplate reader capable of measuring absorbance at 340 nm. Measure the absorbance every 30 seconds for 10-20 minutes at room temperature.[12]

3. Data Analysis:

- Calculate Reaction Rate (V): For each well, determine the rate of reaction by calculating the slope of the linear portion of the absorbance vs. time curve ($\Delta\text{Abs}/\text{min}$).
- Calculate Percent Inhibition:
 - Activity (%) = $[(V_{\text{EC}} - V_{\text{Sample}}) / V_{\text{EC}}] \times 100$
- Determine IC_{50} : Plot the Percent Inhibition against the logarithm of the test compound concentration. Fit the data to a sigmoidal dose-response curve to determine the IC_{50} value, which is the concentration of the inhibitor required to reduce enzyme activity by 50%.

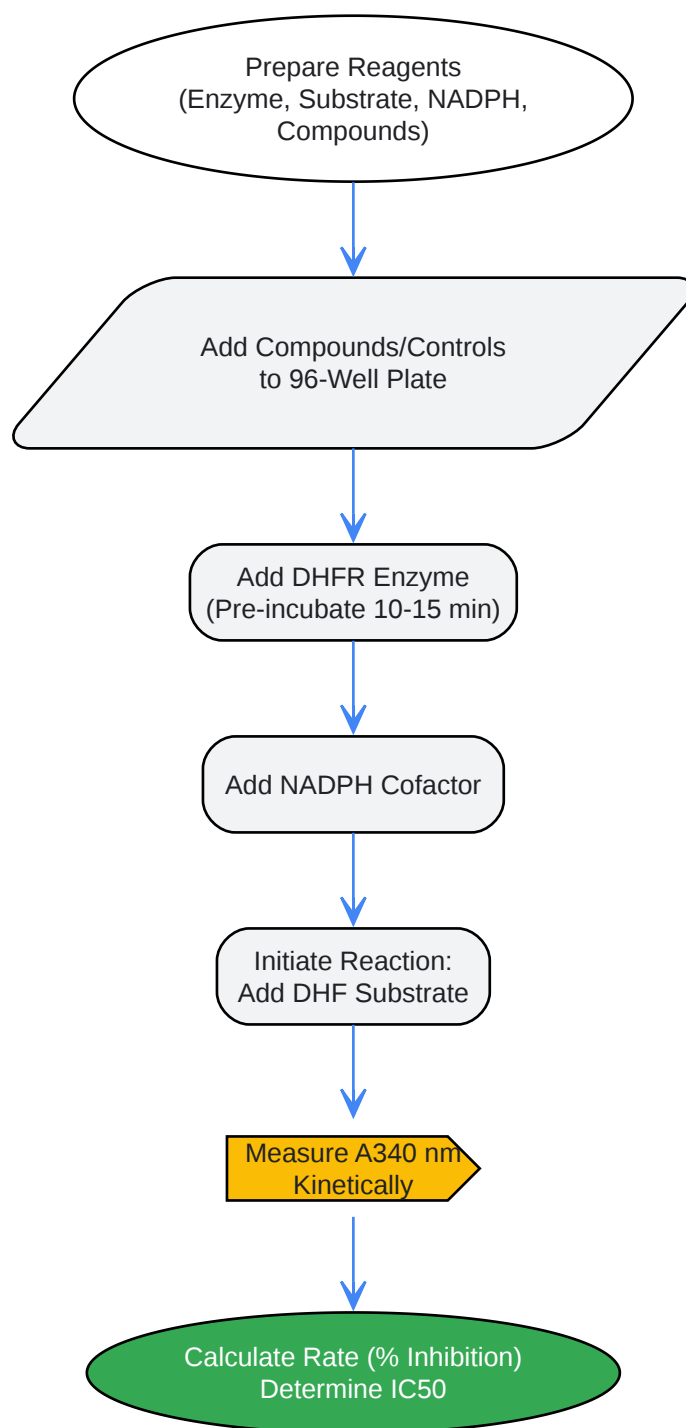

[Click to download full resolution via product page](#)

Caption: Workflow for a DHFR Enzymatic Inhibition Assay.

Part 2: Cell-Based Assays for Determining Cellular Efficacy

While enzymatic assays are essential for confirming direct target inhibition, they do not provide information on a compound's ability to enter a cell and exert its effect in a complex biological environment. Cell-based assays are therefore a critical next step to evaluate properties like membrane permeability, susceptibility to efflux pumps, and intracellular metabolic activation or deactivation.[15]

Protocol 1: Antiproliferation Assay

This assay measures the ability of a compound to inhibit the growth and division of cells, which is the ultimate downstream effect of successful folate pathway inhibition.

Principle: By disrupting DNA synthesis, antifolates cause cell cycle arrest, primarily in the S-phase, and inhibit cell proliferation.[8] This can be quantified by measuring cell viability or DNA synthesis after a set incubation period. Common readout methods include MTT/XTT assays (measuring metabolic activity) or BrdU/EdU incorporation assays (measuring DNA synthesis). [8][16]

Detailed Protocol: Cell Proliferation Assay using MTT

1. Cell Culture and Seeding:

- Select an appropriate cell line (e.g., HeLa or A549 for cancer; *Bacillus subtilis* for bacteria). [17]
- Culture cells to ~70-80% confluency in their recommended growth medium.
- Trypsinize (for adherent cells), count, and seed the cells into a 96-well flat-bottom plate at a predetermined optimal density (e.g., 5,000 cells/well).
- Incubate for 24 hours to allow cells to attach and resume growth.

2. Compound Treatment:

- Prepare a serial dilution of the test antifolate compound in the appropriate cell culture medium.
- Carefully remove the old medium from the wells and add 100 μ L of the medium containing the test compound at various concentrations. Include a vehicle control (e.g., DMSO) and a positive control (methotrexate).
- Incubate the plate for 48-72 hours. The incubation time should be sufficient for at least two cell doublings in the control group.[16]

3. MTT Readout:

- Prepare a 5 mg/mL stock solution of MTT (3-(4,5-dimethylthiazol-2-yl)-2,5-diphenyltetrazolium bromide) in sterile PBS.
- Add 10 μ L of the MTT stock solution to each well and incubate for 3-4 hours at 37°C. During this time, viable cells with active mitochondrial reductases will convert the yellow MTT into purple formazan crystals.
- Add 100 μ L of MTT Solubilization Solution (e.g., 10% SDS in 0.01 M HCl) to each well.
- Incubate the plate overnight in the incubator or for a few hours at room temperature with gentle shaking to fully dissolve the formazan crystals.
- Measure the absorbance at 570 nm using a microplate reader.

4. Data Analysis:

- Subtract the average absorbance of blank wells (medium only) from all other wells.
- Normalize the data by expressing the absorbance of treated wells as a percentage of the vehicle control wells (% Viability).
- Plot the % Viability against the logarithm of the compound concentration and fit the data to a sigmoidal dose-response curve to determine the GI₅₀ (concentration for 50% Growth Inhibition) or IC₅₀ value.

Protocol 2: Folate Rescue Assay for Mechanism Confirmation

A key experiment to validate that a compound's antiproliferative activity is specifically due to targeting the folate pathway is the "rescue" assay.

Principle: If a compound inhibits cell growth by blocking DHFR, this effect should be reversible by supplying the cells with a downstream product of the folate pathway that bypasses the enzymatic block. Folinic acid (leucovorin) is a reduced folate that can be directly utilized by cells for nucleotide synthesis, thereby "rescuing" them from the effects of a DHFR inhibitor.[18]

Detailed Protocol:

- Setup: Perform the antiproliferation assay as described above.
- Parallel Treatments: For each concentration of your test compound, set up two parallel treatment conditions:
 - Condition A: Test compound alone.
 - Condition B: Test compound + a fixed, non-toxic concentration of folinic acid (e.g., 10 μ M).
- Incubation and Readout: Incubate the plates and perform the MTT readout as previously described.
- Data Analysis:
 - Calculate and plot the dose-response curves for both conditions (with and without folinic acid) on the same graph.
 - Interpretation: A significant rightward shift in the IC_{50} value in the presence of folinic acid provides strong evidence that the compound's primary mechanism of action is the inhibition of the folate pathway. If there is no shift, the compound likely acts through a different mechanism.

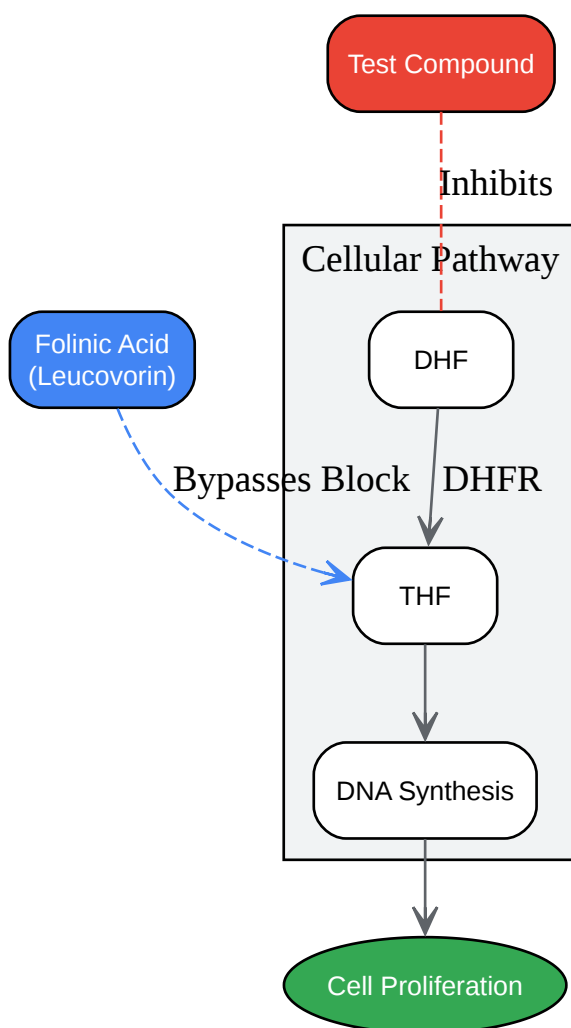

[Click to download full resolution via product page](#)

Caption: Logic of the Folate Rescue Assay.

Part 3: Characterizing and Overcoming Antifolate Resistance

A major challenge in antifolate therapy is the development of drug resistance.[2] Understanding if a new compound is susceptible to known resistance mechanisms is crucial for its development. Common mechanisms of resistance to classical antifolates like methotrexate include:

- Mutations in the target DHFR enzyme that reduce drug binding affinity.[9][19]

- Gene amplification leading to overexpression of the DHFR enzyme.[9][19]
- Impaired drug transport into the cell due to mutations or reduced expression of folate transporters like the reduced folate carrier (RFC).[9][20]
- Defective polyglutamation of the drug inside the cell, which is necessary for its retention and full activity.[9][15]

Experimental Approach: Comparative Potency in Resistant Cell Lines

A straightforward method to assess potential cross-resistance is to compare the antiproliferative activity of a novel compound against a parental, drug-sensitive cell line and its derived subline that has known resistance to methotrexate.

Protocol:

- Obtain Cell Lines: Acquire a pair of well-characterized cell lines, such as a wild-type cancer cell line and a methotrexate-resistant (MTX-R) variant.
- Perform Parallel Assays: Conduct the antiproliferation assay (as described in Part 2) simultaneously on both the sensitive (parental) and resistant cell lines.
- Data Analysis:
 - Determine the IC_{50} value for your test compound in both cell lines.
 - Calculate the Resistance Factor (RF): $RF = IC_{50} \text{ (Resistant Line)} / IC_{50} \text{ (Sensitive Line)}$

Interpretation of Results:

Resistance Factor (RF)	Interpretation	Implication for Novel Compound
RF \approx 1	No cross-resistance observed.	The compound may overcome the specific resistance mechanism present in the MTX-R line.
RF > 10	Significant cross-resistance.	The compound is likely affected by the same resistance mechanism as methotrexate.
1 < RF < 10	Partial cross-resistance.	The compound may be partially affected by the resistance mechanism.

This comparative analysis provides critical early insights into whether a new antifolate might offer an advantage over existing therapies in a clinically relevant resistance setting.[9]

References

- Exploring the Antifolate Activity of Novel Compounds: An In-depth Technical Guide - Benchchem. (URL:)
- Screening and In Vitro Testing of Antifolate Inhibitors of Human Cytosolic Serine Hydroxymethyltransferase - PubMed Central. (URL:)
- In vitro activities of and mechanisms of resistance to antifol antimalarial drugs - PMC - NIH. (URL:)
- Dihydrofolate Reductase Enzyme Inhibition Assay for Plasma Methotrexate Determination Using a 96-Well Micropl
- Antibacterial Antifolates: From Development through Resistance to the Next Gener
- Folate Pathway Inhibitors, An Underestimated and Underexplored Molecular Target for New Anti-tuberculosis Agents - PubMed. (URL:)
- Folate biosynthesis pathway: mechanisms and insights into drug design for infectious diseases - PubMed. (URL:)
- ab283374 – Dihydrofolate reductase (DHFR) Inhibitor Screening Kit (Colorimetric) | Abcam. (URL:)
- Cellular and molecular mechanisms of resistance to antifolate drugs: new analogues and approaches to overcome the resistance - PubMed. (URL:)

- Methotrexate: Folate Antagonist Workflows for Apoptosis a... - Inhibitor Research Hub. (URL:)
- Dihydrofolate Reductase Inhibitor Screening Kit (Colorimetric) - Assay Genie. (URL:)
- The molecular basis of antifolate resistance in Plasmodium falciparum: looking beyond point mut
- Dihydrofolate Reductase Enzyme Inhibition Assay for Plasma Methotrexate Determination Using a 96-Well Microplate Reader | Clinical Chemistry | Oxford Academic. (URL:)
- Utility of the Biosynthetic Folate Pathway for Targets in Antimicrobial Discovery - PMC. (URL:)
- Comprehensive overview of pharmacological agents targeting folate... | Download Scientific Diagram - ResearchGate. (URL: [\[Link\]](#))
- Dihydrofolate Reductase Activity Kit (Colorimetric) (#BN00511) - Assay Genie. (URL:)
- Understanding and Overcoming Antifolate Resistance in Methicillin-resistant Staphylococcus aureus - Digital Commons @ UConn - University of Connecticut. (URL: [\[Link\]](#))
- A Focused Screen Identifies Antifolates with Activity on Mycobacterium tuberculosis - NIH. (URL:)
- In vitro activities of novel antifolate drug combinations against Plasmodium falciparum and human granulocyte CFUs | Antimicrobial Agents and Chemotherapy - ASM Journals. (URL:)
- Methotrexate modulates folate phenotype and inflammatory profile in EA.hy 926 cells - PMC. (URL:)
- Folate | Linus Pauling Institute - Oregon State University. (URL: [\[Link\]](#))
- A novel antifolate suppresses growth of FPGS-deficient cells and overcomes methotrexate resistance | Life Science Alliance. (URL: [\[Link\]](#))
- Folate status and the safety profile of antifolates - PubMed. (URL: [\[Link\]](#))
- Clinical and pharmacokinetic phase I study of multitargeted antifolate (LY231514) in combination with cisplatin - PubMed. (URL: [\[Link\]](#))
- Antifolate - Wikipedia. (URL: [\[Link\]](#))
- The Antifolates - PMC - PubMed Central - NIH. (URL:)

- Clinical pharmacokinetics of antitumor antifolates - PubMed. (URL: [\[Link\]](#))
- New Antifolates in Clinical Development | CancerNetwork. (URL: [\[Link\]](#))
- Methotrexate Provokes Disparate Folate Metabolism Gene Expression and Alternative Splicing in Ex Vivo Monocytes and GM-CSF- and M-CSF-Polarized Macrophages - MDPI. (URL: [\[Link\]](#))
- Antifolates in cancer therapy: structure, activity and mechanisms of drug resistance - PubMed. (URL: [\[Link\]](#))
- Effect of folate derivatives on the activity of antifolate drugs used against malaria and cancer - PMC - NIH. (URL:)
- The evaluation of red blood cell folate and methotrexate levels during protocol M in childhood acute lymphoblastic leukemia - PubMed Central. (URL:)
- Folate tests for suspected folate deficiency - HTA Database. (URL: [\[Link\]](#))
- A Whole-Cell Assay for Detection of Antibacterial Activity in Actinomycete Culture Supernatants - PubMed. (URL: [\[Link\]](#))
- Toxoplasmosis - Wikipedia. (URL: [\[Link\]](#))
- Cell-Free Supernatant from a Strain of Bacillus siamensis Isolated from the Skin Showed a Broad Spectrum of Antimicrobial Activity - MDPI. (URL: [\[Link\]](#))

Need Custom Synthesis?

BenchChem offers custom synthesis for rare earth carbides and specific isotopic labeling.

Email: info@benchchem.com or [Request Quote Online](#).

Sources

- 1. pdf.benchchem.com [pdf.benchchem.com]
- 2. Antifolate - Wikipedia [en.wikipedia.org]
- 3. Folate | Linus Pauling Institute | Oregon State University [lpi.oregonstate.edu]

- 4. Antibacterial Antifolates: From Development through Resistance to the Next Generation - PMC [[pmc.ncbi.nlm.nih.gov](https://pubmed.ncbi.nlm.nih.gov/)]
- 5. A Focused Screen Identifies Antifolates with Activity on Mycobacterium tuberculosis - PMC [[pmc.ncbi.nlm.nih.gov](https://pubmed.ncbi.nlm.nih.gov/)]
- 6. Folate Pathway Inhibitors, An Underestimated and Underexplored Molecular Target for New Anti-tuberculosis Agents - PubMed [pubmed.ncbi.nlm.nih.gov]
- 7. Utility of the Biosynthetic Folate Pathway for Targets in Antimicrobial Discovery - PMC [[pmc.ncbi.nlm.nih.gov](https://pubmed.ncbi.nlm.nih.gov/)]
- 8. mcherry-sarna.com [mcherry-sarna.com]
- 9. Cellular and molecular mechanisms of resistance to antifolate drugs: new analogues and approaches to overcome the resistance - PubMed [pubmed.ncbi.nlm.nih.gov]
- 10. assaygenie.com [assaygenie.com]
- 11. assaygenie.com [assaygenie.com]
- 12. scispace.com [scispace.com]
- 13. academic.oup.com [academic.oup.com]
- 14. content.abcam.com [content.abcam.com]
- 15. A novel antifolate suppresses growth of FPGS-deficient cells and overcomes methotrexate resistance | Life Science Alliance [life-science-alliance.org]
- 16. Methotrexate modulates folate phenotype and inflammatory profile in EA.hy 926 cells - PMC [[pmc.ncbi.nlm.nih.gov](https://pubmed.ncbi.nlm.nih.gov/)]
- 17. A Whole-Cell Assay for Detection of Antibacterial Activity in Actinomycete Culture Supernatants - PubMed [pubmed.ncbi.nlm.nih.gov]
- 18. The evaluation of red blood cell folate and methotrexate levels during protocol M in childhood acute lymphoblastic leukemia - PMC [[pmc.ncbi.nlm.nih.gov](https://pubmed.ncbi.nlm.nih.gov/)]
- 19. cancernetwork.com [cancernetwork.com]
- 20. The Antifolates - PMC [[pmc.ncbi.nlm.nih.gov](https://pubmed.ncbi.nlm.nih.gov/)]
- To cite this document: BenchChem. [Application Notes & Protocols: A Guide to the Experimental Evaluation of Antifolate Activity]. BenchChem, [2026]. [Online PDF]. Available at: [<https://www.benchchem.com/product/b121800/docs#application-notes-protocols-a-guide-to-the-experimental-evaluation-of-antifolate-activity>]

Disclaimer & Data Validity:

The information provided in this document is for Research Use Only (RUO) and is strictly not intended for diagnostic or therapeutic procedures. While BenchChem strives to provide accurate protocols, we make no warranties, express or implied, regarding the fitness of this product for every specific experimental setup.

Technical Support: The protocols provided are for reference purposes. Unsure if this reagent suits your experiment?

Need Industrial/Bulk Grade? [Request Custom Synthesis Quote](#)

BenchChem

Our mission is to be the trusted global source of essential and advanced chemicals, empowering scientists and researchers to drive progress in science and industry.

Contact

Address: 3281 E Guasti Rd
Ontario, CA 91761, United States
Phone: (601) 213-4426
Email: info@benchchem.com

[Contact our Ph.D. Support Team for a compatibility check](#)