

# Aminopyridine Compounds: Technical Support Center

**Author:** BenchChem Technical Support Team. **Date:** May 2026

## Compound of Interest

Compound Name: 2-(Aminomethyl)pyridin-3-amine

CAS No.: 144288-50-6

Cat. No.: B121225

[Get Quote](#)

This technical support center provides essential information for researchers, scientists, and drug development professionals working with aminopyridine compounds. It includes detailed handling precautions, troubleshooting guides for common experimental issues, and frequently asked questions to ensure safe and effective laboratory work.

## Frequently Asked Questions (FAQs)

Q1: What are the primary hazards associated with aminopyridine compounds?

A1: Aminopyridine compounds are highly toxic and pose significant health risks. The primary hazards include:

- Acute Toxicity: They can be fatal if swallowed, inhaled, or absorbed through the skin.<sup>[1][2][3][4][5]</sup> Overexposure can lead to symptoms such as headache, dizziness, nausea, high blood pressure, respiratory distress, convulsions, and even death.<sup>[1][3][4][6]</sup>
- Irritation: These compounds are irritating to the skin, eyes, mucous membranes, and upper respiratory tract.<sup>[1][2][3]</sup>

- Organ Toxicity: Repeated exposure may cause damage to the central nervous system, liver, and other organs.[1][4]

Q2: What are the recommended personal protective equipment (PPE) when handling aminopyridines?

A2: A comprehensive PPE strategy is crucial for safely handling aminopyridines. The following should be worn:

- Hand Protection: Double-gloving with two pairs of chemical-resistant gloves (e.g., nitrile) is recommended.[1] Always consult the glove manufacturer's compatibility chart.
- Eye Protection: ANSI-approved safety glasses or chemical splash goggles are required.[1]
- Skin and Body Protection: A fully buttoned laboratory coat, full-length pants, and closed-toe shoes are mandatory to prevent skin exposure.[1]
- Respiratory Protection: When working with powders or in situations where aerosol or dust formation is possible, a NIOSH-approved respirator should be used.[3][7] All handling of aminopyridines should ideally be done within a certified chemical fume hood.[1][3]

Q3: What are the established occupational exposure limits for aminopyridine compounds?

A3: For 2-aminopyridine, several organizations have established exposure limits.[8][9] As of now, no official standards have been set by NIOSH or OSHA for 3-aminopyridine or 4-aminopyridine.[8]

| Organization        | Compound        | Exposure Limit (Time-Weighted Average)                            |
|---------------------|-----------------|---|
| OSHA                | 2-Aminopyridine | 0.5 ppm (2 mg/m <sup>3</sup> ) over an 8-hour work shift[6][8][9] |
| NIOSH               | 2-Aminopyridine | 0.5 ppm (2 mg/m <sup>3</sup> ) over a 10-hour work shift[8][9]    |
| ACGIH               | 2-Aminopyridine | 0.5 ppm (1.9 mg/m <sup>3</sup> ) over an 8-hour work shift[8]     |
| OSHA (Vacated PELs) | 4-Aminopyridine | 0.5 ppm TWA; 2 mg/m <sup>3</sup> TWA[4]                           |

Q4: What should I do in case of accidental exposure to an aminopyridine compound?

A4: Immediate action is critical in the event of an exposure. Follow these first-aid measures:

- Skin Contact: Immediately remove all contaminated clothing. Wash the affected area thoroughly with soap and plenty of water for at least 15 minutes. Seek immediate medical attention.[1][2][3][5]
- Eye Contact: Immediately flush the eyes with plenty of water for at least 15 minutes, occasionally lifting the upper and lower eyelids. Remove contact lenses if present and easy to do. Seek immediate medical attention.[1][2][3][5]
- Inhalation: Move the individual to fresh air. If breathing is difficult or has stopped, provide artificial respiration. Seek immediate medical attention.[1][3][5]
- Ingestion: Do NOT induce vomiting. Rinse the mouth with water. Seek immediate medical attention.[2][3][5]

Always have the Safety Data Sheet (SDS) available to provide to emergency medical personnel.[1]

## Troubleshooting Experimental Issues

Problem 1: Inconsistent results in electrophysiology experiments using 4-aminopyridine.

- Possible Cause 1: Solution Instability. Aqueous solutions of 4-aminopyridine are not recommended for storage for more than one day.[\[10\]](#)
  - Solution: Prepare fresh solutions of 4-aminopyridine for each experiment.
- Possible Cause 2: Incorrect Concentration. The efficacy of 4-aminopyridine as a potassium channel blocker is concentration-dependent.[\[11\]](#)
  - Solution: Perform a dose-response curve to determine the optimal concentration for your specific experimental setup and cell type.
- Possible Cause 3: pH of the Solution. The charge state of 4-aminopyridine, and thus its ability to cross cell membranes and interact with its target, can be influenced by pH.
  - Solution: Ensure the pH of your buffer is consistent across all experiments.

Problem 2: Poor solubility of aminopyridine compounds in desired solvents.

- Possible Cause: Inappropriate Solvent Choice. Aminopyridines have varying solubilities in different organic and aqueous solvents.
  - Solution: Refer to the solubility data below. For aqueous solutions of 4-aminopyridine, heating may be required to achieve complete dissolution.[\[12\]](#) Stock solutions in organic solvents like DMSO or ethanol can be prepared and then diluted into aqueous buffers.[\[10\]](#)

## Quantitative Data Summary

## Toxicity Data of Aminopyridine Compounds

| Compound        | Species      | Route of Administration | LD50 (mg/kg) | Source |
|-----------------|--------------|-------------------------|--------------|--------|
| 2-Aminopyridine | Rat          | Oral                    | 200          | [13]   |
|                 | Mouse        | Oral                    | 50           | [13]   |
|                 | Mouse        | Intravenous             | 23           | [13]   |
|                 | Quail        | Oral                    | 133          | [8]    |
| 3-Aminopyridine | Mouse        | Intraperitoneal         | 28           | [8]    |
|                 | Quail        | Oral                    | 178          | [8]    |
| 4-Aminopyridine | Rat          | Oral                    | 20           | [14]   |
|                 | Rabbit       | Dermal                  | 327          | [4]    |
|                 | Mouse        | Intravenous             | 7            | [4]    |
|                 | Human (LDLo) | Oral                    | 0.59         | [4]    |

LDLo: Lowest published lethal dose.

## Solubility of Aminopyridine Compounds

| Compound                     | Solvent   | Solubility           | Temperature (°C) | Source |
|------------------------------|-----------|----------------------|------------------|--------|
| 2-Aminopyridine              | Acetone   | High                 | 15-40            | [15]   |
| Chloroform                   | Low       | 15-45                | [15]             |        |
| Ethyl Acetate                | Medium    | 15-50                | [15]             |        |
| N-methyl-2-pyrrolidone (NMP) | Very High | 0-40                 | [16]             |        |
| Cyclohexane                  | Very Low  | 0-40                 | [16]             |        |
| 4-Aminopyridine              | Water     | 50 mg/mL (with heat) | Not specified    | [12]   |
| Water                        | 112 g/L   | 20                   | [17]             |        |
| Ethanol, DMSO, DMF           | ~30 mg/mL | Not specified        | [10]             |        |
| PBS (pH 7.2)                 | ~30 mg/mL | Not specified        | [10]             |        |

## Experimental Protocols & Methodologies

### General Protocol for Handling and Weighing Solid Aminopyridine Compounds

- Preparation: Before handling, ensure a certified chemical fume hood is operational. Gather all necessary PPE, including double gloves, safety goggles, and a lab coat.
- Weighing:
  - Perform all weighing activities within the fume hood.
  - Use a disposable weighing dish or boat to prevent contamination of the balance.
  - Handle the compound with a dedicated spatula.

- Close the primary container tightly immediately after use.[\[1\]](#)[\[18\]](#)
- Dissolution:
  - Add the solvent to the weighed aminopyridine compound within the fume hood.
  - If necessary, cap the vial or flask and sonicate or vortex to aid dissolution. For aqueous solutions of 4-aminopyridine, gentle heating may be applied.[\[12\]](#)
- Cleanup:
  - Wipe down the balance and surrounding area within the fume hood with a damp cloth or paper towel.
  - Dispose of all contaminated materials (weighing boat, gloves, wipes) as hazardous waste.[\[18\]](#)
- Hygiene: Wash hands thoroughly with soap and water after the procedure is complete.[\[1\]](#)

## Protocol for a Three-Component One-Pot Synthesis of 2-Aminopyridine Derivatives

This protocol is based on a general method for the synthesis of substituted 2-aminopyridines.[\[19\]](#)[\[20\]](#)

- Reactant Preparation: In a round-bottom flask, combine the aldehyde or ketone (1 mmol), the active methylene compound (e.g., ethyl cyanoacetate, 1 mmol), and the amine or ammonia source (e.g., morpholine, 1.2 mmol).
- Reaction Conditions:
  - Add the appropriate catalyst and solvent (e.g., ethanol).[\[19\]](#)
  - Stir the reaction mixture at the specified temperature (e.g., 80°C) for the required time (e.g., 3 hours).[\[20\]](#)
- Monitoring: Monitor the progress of the reaction using Thin Layer Chromatography (TLC).

- Work-up and Purification:
  - Once the reaction is complete, cool the mixture to room temperature.
  - Remove the solvent under reduced pressure.
  - Purify the crude product by column chromatography on silica gel using an appropriate eluent system.
- Characterization: Characterize the purified 2-aminopyridine derivative using spectroscopic methods such as FTIR,  $^1\text{H}$  NMR, and  $^{13}\text{C}$  NMR.[20]

## Visualizations

### Signaling Pathway of 4-Aminopyridine in Pulmonary Vasoconstriction

4-Aminopyridine Induced Pulmonary Vasoconstriction Pathway

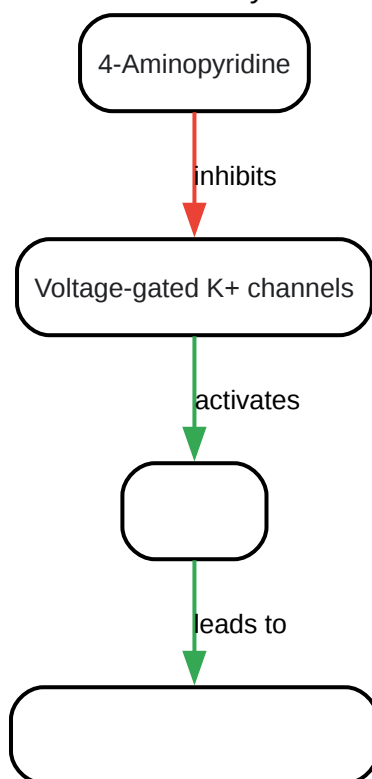

[Click to download full resolution via product page](#)

Caption: Role of ERK1/2 in 4-AP induced vasoconstriction.

## Experimental Workflow for Handling Aminopyridine Compounds

## Safe Handling Workflow for Aminopyridine Compounds

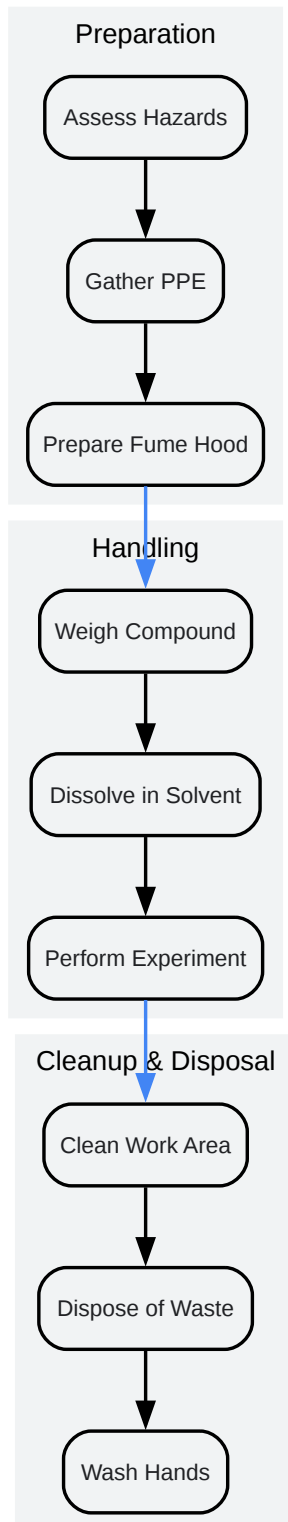

[Click to download full resolution via product page](#)

Caption: Step-by-step safe handling workflow.

## Logical Relationship for Spill Response

### Aminopyridine Spill Response Logic

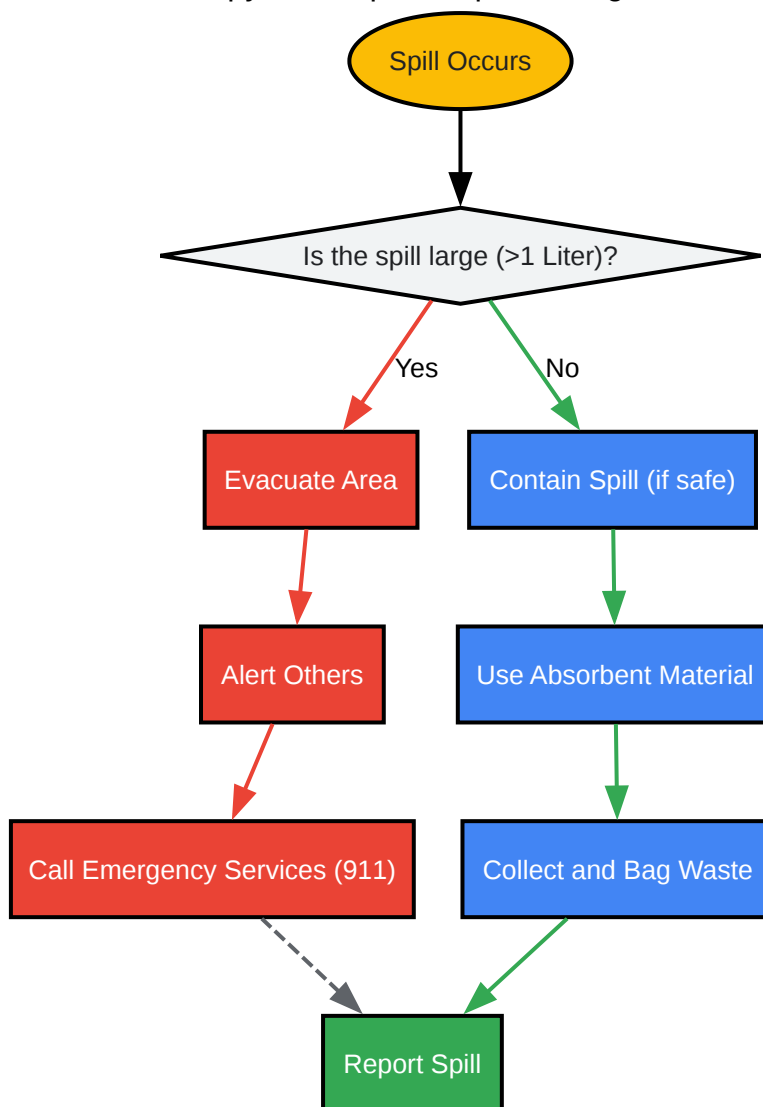

[Click to download full resolution via product page](#)

Caption: Decision-making for aminopyridine spills.

### ***Need Custom Synthesis?***

*BenchChem offers custom synthesis for rare earth carbides and specific isotopic labeling.*

*Email: [info@benchchem.com](mailto:info@benchchem.com) or [Request Quote Online](#).*

## References

- [1. ehs.washington.edu](https://ehs.washington.edu) [[ehs.washington.edu](https://ehs.washington.edu)]
- [2. jubilantingrevia.com](https://jubilantingrevia.com) [[jubilantingrevia.com](https://jubilantingrevia.com)]
- [3. alkalimetals.com](https://alkalimetals.com) [[alkalimetals.com](https://alkalimetals.com)]
- [4. jubilantingrevia.com](https://jubilantingrevia.com) [[jubilantingrevia.com](https://jubilantingrevia.com)]
- [5. lobachemie.com](https://lobachemie.com) [[lobachemie.com](https://lobachemie.com)]
- [6. CDC - NIOSH Pocket Guide to Chemical Hazards - 2-Aminopyridine](https://www.cdc.gov/niosh/pocketguide/) [[cdc.gov](https://www.cdc.gov/niosh/pocketguide/)]
- [7. biochemopharma.fr](https://www.biochemopharma.fr) [[biochemopharma.fr](https://www.biochemopharma.fr)]
- [8. epa.gov](https://www.epa.gov) [[epa.gov](https://www.epa.gov)]
- [9. nj.gov](https://www.nj.gov) [[nj.gov](https://www.nj.gov)]
- [10. cdn.caymanchem.com](https://cdn.caymanchem.com) [[cdn.caymanchem.com](https://cdn.caymanchem.com)]
- [11. Cracking the code: the clinical and molecular impact of aminopyridines; a review \(2019–2024\) - RSC Advances \(RSC Publishing\) DOI:10.1039/D4RA07438F](https://pubs.rsc.org) [[pubs.rsc.org](https://pubs.rsc.org)]
- [12. sigmaaldrich.com](https://www.sigmaaldrich.com) [[sigmaaldrich.com](https://www.sigmaaldrich.com)]
- [13. benchchem.com](https://www.benchchem.com) [[benchchem.com](https://www.benchchem.com)]
- [14. cameochemicals.noaa.gov](https://cameochemicals.noaa.gov) [[cameochemicals.noaa.gov](https://cameochemicals.noaa.gov)]
- [15. pubs.acs.org](https://pubs.acs.org) [[pubs.acs.org](https://pubs.acs.org)]
- [16. pubs.acs.org](https://pubs.acs.org) [[pubs.acs.org](https://pubs.acs.org)]
- [17. 4-Aminopyridine, 98% | Fisher Scientific](https://www.fishersci.ca) [[fishersci.ca](https://www.fishersci.ca)]
- [18. research.uga.edu](https://research.uga.edu) [[research.uga.edu](https://research.uga.edu)]
- [19. benchchem.com](https://www.benchchem.com) [[benchchem.com](https://www.benchchem.com)]
- [20. Efficient Synthesis of 2-Aminopyridine Derivatives: Antibacterial Activity Assessment and Molecular Docking Studies - PMC](https://pubmed.ncbi.nlm.nih.gov) [[pmc.ncbi.nlm.nih.gov](https://pubmed.ncbi.nlm.nih.gov)]
- To cite this document: BenchChem. [Aminopyridine Compounds: Technical Support Center]. BenchChem, [2026]. [Online PDF]. Available at: [<https://www.benchchem.com/product/b121225/docs#aminopyridine-compounds-technical-support-center>]

---

### Disclaimer & Data Validity:

The information provided in this document is for Research Use Only (RUO) and is strictly not intended for diagnostic or therapeutic procedures. While BenchChem strives to provide accurate protocols, we make no warranties, express or implied, regarding the fitness of this product for every specific experimental setup.

**Technical Support:** The protocols provided are for reference purposes. Unsure if this reagent suits your experiment?

**Need Industrial/Bulk Grade?** [Request Custom Synthesis Quote](#)

## BenchChem

Our mission is to be the trusted global source of essential and advanced chemicals, empowering scientists and researchers to drive progress in science and industry.

### Contact

Address: 3281 E Guasti Rd  
Ontario, CA 91761, United States  
Phone: (601) 213-4426  
Email: [info@benchchem.com](mailto:info@benchchem.com)

[Contact our Ph.D. Support Team for a compatibility check](#)